

# RTL-24 Standing Seam Roof

## Installation Guide

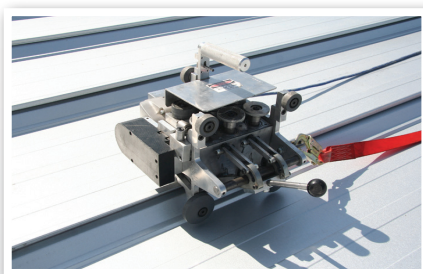

### **IMPORTANT INFORMATION**

Any person installing or seaming a Steelway RTL-24 Standing Seam Roof System must read and understand this document before any work is started. Failure to do so can cause severe damage to the roof system and will void all product and performance warranties.

---

**BLANK**

# INDEX

<b>1.0 Introduction</b>		<b>9.0 Roof Installation Details</b>	
1.1 Purpose Of The Installation Guide.....	1-1	9.1 General .....	9-1
1.2 Customer's Responsibility .....	1-1	9.2 Preparation for Roof Panel Installation ...	9-2
<b>2.0 Safe Roof Installation</b>		9.3 Roof Panel Installation .....	9-6
2.1 Erector's Responsibility .....	2-2	9.4 Preparation for Termination	
2.2 OSHA (USA), WHMIS (Canada) .....	2-2	Panel Installation .....	9-31
2.3 Walking & Working On Roof Panels .....	2-3	9.5 Termination Panel Installation .....	9-36
2.4 Handling Roof Materials In Strong Winds	2.4	9.6 End Dam Installation.....	9-41
2.5 Importance of Seaming.....	2-5	9.7 Eave Trim Installation .....	9-50
<b>3.0 Checking The Structure</b>		9.8 Gable Trim Installation .....	9-54
3.1 Completed And Braced .....	3-1	9.9 Gable Transition Installation .....	9-63
3.2 Lateral Stability .....	3-1	9.10 Ridge Cover Installation.....	9-63
3.3 Alignment.....	3-1	9.11 High Eave Transition Installation .....	9-72
<b>4.0 Receiving &amp; Handling Roof Materials</b>		9.12 Eave Gutter Installation .....	9-76
4.1 Material Inventory .....	4-1	9.13 Hip and Valley Installation.....	9-80
4.2 Equipment For Unloading And Lifting .....	4-1		
4.3 Lifting Roof Panel Bundles .....	4-1		
4.4 Field Storage Of Roof Materials .....	4-2		
4.5 Handling Individual Roof Panels.....	4-2		
<b>5.0 Roof Installation Basics</b>			
5.1 Proper Tools.....	5-1		
5.2 Equipment List .....	5-1		
5.3 Sealants .....	5-1		
5.4 Fasteners .....	5-3		
5.5 Field Cutting Panels And Flashing .....	5-4		
<b>6.0 Roof Panel Layout</b>			
6.1 Sheeting Direction And Modularity.....	6-1		
6.2 Panel Notching .....	6-2		
6.3 Layout & Checking For Coverage.....	6-2		
6.4 Appearance Considerations .....	6-2		
<b>7.0 Inspection Of Roof Assembly During Installation</b>			
7.1 Importance Of Inspection.....	7-1		
7.2 Inspection List.....	7-1		
<b>8.0 Standard Parts</b>			
8.1 General .....	8-1		
8.2 Roof Panels & Closures.....	8-2		
8.3 Panel Clips, Gutter Bracket & Endlap & Termination Parts.....	8-3		
8.4 Eave/Gable Plates & Spacer Blocks.....	8-4		
8.5 Fasteners .....	8-5		
8.6 Fasteners & Sealants .....	8-6		

BLANK

## 1.0 INTRODUCTION



### 1.1 PURPOSE OF THE INSTALLATION GUIDE

The seaming guide is provided by **Steelway Building Systems** to you the customer, builder or erector as the recommended procedures for the correct seaming of the Steelway RTL-24 Standing Seam Roof System.

This guide is intended to be used in conjunction with the project's erection drawings to help plan and organize the installation of the Steelway Standing Seam Roof System. The erection drawings identify the applicable roof conditions and govern specific part arrangements. The instructions will help you identify parts, establish the installation sequence, demonstrate correct assembly, and point out any areas or procedures requiring special emphasis or attention.

This installation guide applies to the standard Steelway Standing Seam Roof System. Custom roof conditions, including custom details and instructions, will be covered by the erection drawings. In case of conflict between this installation guide and the erection drawings, the erection drawings will have precedence.

### 1.2 CUSTOMER'S RESPONSIBILITY

The customer is responsible for proper installation of the roof in accordance with the erection drawings and this installation guide, and in accordance with good engineering and construction practices.

The customer must take the responsibility for selecting a competent erector, insist that the work be performed by qualified and experienced standing seam metal roof installers, insist that the erector take time to study and understand this guide, then assure that the erector correctly follows the guide's instructions.

Steelway does not guarantee and is not liable for the quality of erection. Steelway is not responsible for building defects that may be attributed to improper erection or the negligence of other parties.

Clarification concerning the Steelway roof installation should be directed to your Project Manager. Contact the office at:

**Steelway Building Systems**  
**7825 Springwater Road**  
**Aylmer, Ontario, Canada**  
**N5H 2R4**

**t. 1.800.264.7740**  
**f. 519.773.7398**  
**steelway.com**

## 2.0 SAFE ROOF INSTALLATION



### 2.1 ERECTOR'S RESPONSIBILITY

The erector of the roof system is responsible for the safe execution of this installation guide. These instructions are intended to describe the sequence and proper placement of parts. They are not intended to prescribe comprehensive safety procedures.

If the erector cannot safely assemble the roof in accordance with these instructions, it is the responsibility of the erector to stop the work and contact Steelway to determine alternate assembly procedures.

### 2.2 OSHA (USA)

The Occupational Safety and Health Act (OSHA) has promulgated many regulations applicable to the installation of this or any other roof system. These regulations, identified as Part 1926, Safety and Health Regulations for Construction, are available from any government bookstore. The objective of the OSHA standards is to protect the worker from injury or illness. These OSHA regulations should be complied with and recognized as job site requirements.

Failure to do so may result in substantial fines in the event of an OSHA inspection. Safe installation practices may be further defined and made mandatory by state or local ordinances.

Maintaining good housekeeping on the jobsite is recognized as being important to both OSHA compliance and to successful job completion.

### OHSA AND WHMIS (CANADA)

Occupational Health and Safety Act and Regulations for Construction Projects

Each province has regulations applicable for construction projects. These regulations may be purchased from the Ministry of Labour offices in your province.

The objective of these regulations is to protect the worker from injury or illness. These regulations are law and should be fully complied with on the jobsite. Failure to do so may result in substantial fines, imprisonment or both. Many injuries result from poor housekeeping. Improper storage of materials and cluttered work areas are not safe. To maintain a clean, hazard-free workplace, all groups (management, supervision and workers) must cooperate.

### WHMIS

The Workplace Hazardous Materials Information System (WHMIS) gives everyone the right to know about hazards of materials they work with and provides the means to find out that information.

All employers are required by law to provide WHMIS training for specific controlled products the workers will be working with or near.

## 2.3 WALKING & WORKING ON ROOF PANELS

### A. PLACING PANELS ON THE STRUCTURE

Do not place bundles of panels on the roof structure without first verifying the structure will safely support the concentrated weight of the panels and the weight of the installation crew. Some roof structures may not be designed to support the weight of a full panel bundle without additional structure support.

### B. WALKING ON ROOF PANELS

Do not use a roof panel as a working platform. An unsecured panel could collapse under the weight of a person standing between purlins or at the panel end. Do not walk on the last installed panel run, as the unsecured edge could collapse under a person's weight. When installing clips or making endlap connections, etc., stand where the roof structural will support your weight.

An approved and safe walking platform should be used in high traffic areas to prevent the roof panel from being deformed, scratched, or scuffed.

### C. SAFETY EQUIPMENT

The use of safety equipment for the roof panel installation is recommended at all times during the installation process. However, when using lanyards, ensure that the clasp, belt hooks and wire cables are covered in such a manner that they will not scratch the panel surface if accidentally dragged along the panel.

### D. CREW SIZE

The length of the individual roof panels should be considered when determining the crew size. It is recommended that under normal conditions, there be one person for every ten feet of panel length, plus one.

### E. PANEL OVERHANG

Do not stand on the end of unsupported (cantilevered) panels at the eave or ridge. Standing on the cantilever portion may result in panel collapse.

### F. POINT LOADS

When properly supported by the structurals, panels are designed to support uniform loads, which are evenly distributed over the panel surfaces. Point loads that occur in small or concentrated areas, such as heavy equipment, ladder or platform feet, etc., may cause panel deformation or even panel collapse.

### G. SLICK SURFACES

Panel surfaces and structural steel surfaces are hard, smooth, and nonabsorbent, which causes these surfaces to be very slick when wet or covered with snow or ice. Even blowing sand or heavy dust can make these surfaces difficult to walk on without slipping.

Unpainted panel surfaces are often coated with oil to accommodate the panel-fabrication process. Although designed to wash away or evaporate during normal weather, the oil on new panels can be extremely slick, especially during periods of light rain or dew.

#### CAUTION

Caution must be exercised to prevent slipping and falling onto the roof surface or even sliding off the roof. Non-slip footwear is a necessity and non-slip working platforms are recommended.

## 2.3 WALKING & WORKING ON ROOF PANELS

### H. ELECTRICAL CONDUCTANCE

Metal panels are excellent electrical conductors. A common cause of injury is the contact of metal panels with power lines during handling and installation. The location of all power lines must be noted and, if possible, flagged. The installation process must be routed to avoid accidental contact with all power lines and high voltage services and equipment. All tools and power cords must be properly insulated and grounded and the use of approved ground fault circuit breakers is recommended.

### I. FALSE SECURITY OF INSULATION

Blanket and board insulation blocks the installer's view of the ground below the roof. Serious injury can occur when the installer gets a false sense of security because he cannot see the ground and steps through the insulation.

### J. SHARP EDGES

Some edges of panels and flashing are razor sharp and can cause severe cuts if proper protective hand gear is not worn. Be careful not to injure others while moving panels and flashing.

## 2.4 HANDLING ROOF MATERIALS IN STRONG WINDS

### CAUTION

Do not attempt to move panels in strong winds. Wind pressure can easily cause a man to lose balance and fall. Strong wind uplift on a panel can lift the weight of the man carrying the panel.

Loose, wind borne panels are very dangerous and can cause severe injury and damage.

Secure stacks of panels with banding or tie-downs, so wind will not blow the panels off the roof. Clamp individual unsecured panels to the roof structurals. Clamp or block panel bundles and accessory crates to prevent them from sliding down the roof slope.

## 2.5 IMPORTANCE OF SEAMING

### A. ROOF PERFORMANCE

The roof panels must be correctly seamed before the roof system can provide the full designed wind load and weather resistance capability. This means an uncrimped, unseamed or improperly seamed roof is subject to wind load failure and/or weather resistance failure.

### B. WHEN TO SEAM

Ideally the installed roof panels should be seamed at the finish of each days work. If high wind or rain/snow conditions are imminent, the installed roof panels must be seamed before such conditions occur.

### C. TEMPORARY SEAMING

On roofs requiring TripleLoc and QuadLoc seams, it is often not practical or feasible to power seam the roof panels until after the roof installation is completed. Power seamed roof panels are difficult to reposition or replace and seaming machines may not always be available during the entire roof installation period. Because of this, it is extremely important that all required hand crimping is done while the roof is installed.

The TripleLoc hand crimping is a temporary measure to increase the performance of the roof system. The roof panels must be TripleLoc hand crimped at every roof clip, at each panel end, and each end lap. As soon as possible, complete the seaming with the power seaming machine.

Since TripleLoc hand crimping is required throughout the entire installation, it would be advisable to purchase several TripleLoc hand crimpers to keep for use on a job by job basis. There will be an additional rental hand crimper sent with each power seamer, however its arrival to the job site is too late in the sheeting process to insure against any sudden weather changes or safety issues.

## 3.0 CHECKING THE STRUCTURE

### 3.1 COMPLETED AND BRACED

Before placing materials and workers on the roof structure to start roof installation, it must be confirmed that the structure is designed to accommodate the material and erection loads as well as the appropriate live loads and wind uplift loads.

It also must be determined that the structure is complete and structurally sound with all structural connections and bracing in place and secure.

### 3.2 LATERAL STABILITY

The sliding clip method of attaching the roof panels to the roof structurals provides only limited lateral stability and diaphragm bracing to the roof structurals.

Before placing materials on the roof and starting the roof installation, confirm that the necessary roof bracing, flange braces and purlin stabilizers are in place and secured.

### 3.3 ALIGNMENT

Prior to installation, roof structurals should be checked for overall dimensions and evenness of plane. The roof structurals should also be checked to verify the roof system could be installed without interference. Also, roof structurals nearest the panel endlaps, ridge or high eave should be checked for correct location to properly accommodate the roof components.

#### A. TOLERANCES

To assure the roof system's correct fit-up and designed weather tightness, the structure must be aligned within the following tolerances:

**Out of Square** - The roof system can only accommodate 1/4" of sawtooth of the roof panel ends at the eave, ridge and panel splices. This means the allowable out of square of the rake line relative to the eave line and ridge line is 1/4" for each 40' of rake run.

**Structure Width and Eave Straightness** - The roof system is designed to accommodate  $\pm 2"$  of overall structure width error, or  $\pm 1"$  of eave straightness error at each eave.

To assure that the accumulation of the structure width error and eave straightness error does not exceed the roof system's tolerance, the structure width should be measured from eave line to eave line at each rake, at the first frame line from each rake and at each point where there is a significant error or change in eave straightness (this usually occurs at a frame line or at a wind column).

**Structure Length and Rake Straightness** - The roof system is designed to accommodate  $\pm 2"$  of overall structure length error, or  $\pm 1"$  of rake straightness error at each rake.

To assure that the accumulation of structure length error and rake straightness error does not exceed the roof system's tolerance, the structure length should be measured from rake line to rake line at each eave, at the ridge and at each point where there is a significant error or change in rake straightness (this usually occurs at an end rafter splice).

## 3.0 CHECKING THE STRUCTURE



### **B. MEASURING**

Structure length and width may be measured with a steel measuring tape from the face of the eave or rake member to the face of the opposite eave or rake member. The measuring tape must be parallel to the relative eave or rake line and must be stretched taut.

Eave and rake straightness may be determined by measuring deviations from a string line, which is stretched taut along the eave or rake line.

### **C. AESTHETIC ACCEPTANCE**

Although these structure alignment tolerances will allow for reasonable roof component fit-up and ease of installation, the extremes of these tolerances may be aesthetically objectionable and should be confirmed with the customer before starting the roof installation.

### **D. CORRECTIONS**

Any structure alignment error, which exceeds the above stated tolerances, must be corrected before roof installation can begin. If it is decided that the structure alignment errors cannot be corrected, alternate roof details may have to be developed. The alternate details may require additional materials, modified parts (with additional cost, fabrication and delivery time) and additional installation time. Steelway cannot assure the performance of such alternate details.

## 4.0 RECEIVING & HANDLING ROOF MATERIALS



### 4.1 MATERIAL INVENTORY

Your material is carefully inspected and crated before leaving the plant and accepted by the transportation company as being complete and in satisfactory condition. It is the carrier's responsibility to deliver the shipment intact. It is the consignee's responsibility to inspect the shipment for damages and shortages when it is delivered.

Conducting a material inventory at the time of delivery is essential. By conducting the materials inventory, the erector is able to identify any material shortage or damage and avoid stopping installation later because of such shortage or damage.

It is imperative that any shortages or damage of the delivered materials be noted at once and clearly marked on the bill of lading before signature of acceptance. Notify Steelway immediately of any conflicts. Steelway will not be responsible for shortages or damages unless they are noted on the bill of lading.

In the case of packaged components (such as clips, fasteners and sealants, etc.), the quantities are marked on their container and should be checked against the bill of materials. ***Steelway must be notified of any shortages or concealed damage within 15 days of delivery.***

### 4.2 EQUIPMENT FOR UNLOADING AND LIFTING

Hoisting equipment is necessary to unload and position the panels and accessory crates for site storage and installation. The equipment must have sufficient capacity and reach to place the material where it is required for efficient installation.

Slings will be required to minimize panel damage. The recommended slings are nylon straps of 6" minimum width and of sufficient length to accommodate the panel bundle girth.

A spreader bar will be required for the longer panel crates to assure correct sling spacing and uniform lifting. The spreader bar must be large enough to handle the maximum panel bundle weight and length.

A forklift is handy for unloading and placing shorter panel and accessory crates.

### 4.3 LIFTING ROOF PANEL BUNDLES

Under normal conditions, panel crates less than 35' long can be lifted with two slings spaced at third points. Panel crates longer than 35' can be lifted with three slings located at quarter points using a spreader bar to achieve correct sling spacing for uniform lift.

Slings should be located under the cross boards. Loads should always be checked for secure hook-up, proper balance, and lift clearance. Tag lines should be used if necessary to control the load during lifting, especially if operating in the wind.

Panel crates less than 25' long may be lifted with a forklift only if the forks are spread at least 5' apart and blocking is used to prevent panel damage by the forks.

## 4.0 RECEIVING & HANDLING ROOF MATERIALS



### 4.4 FIELD STORAGE OF ROOF MATERIALS

Upon acceptance of the shipment, the customer or his representative is responsible for proper handling storage and security of the roof materials. Steelway is not liable for damage or loss of materials at the job site.

The roof panel bundles should be stored on the job site in accordance with the following recommendations:

- a. Store panels in a protected area, out of standing water and drifting snow, etc.
- b. Elevate panels with blocking to allow air circulation under the bundle.
- c. Slope panels for drainage of moisture from the panels.
- d. As necessary, cover panels with waterproof tarp, allowing for air circulation (do not wrap tarp under panel crate or restrict air movement).
- e. Inspect panels daily for moisture accumulation.
- f. If panel bundles contain moisture, the panels should be dried and re-stacked. Use care in re-stacking to avoid damage to panels.
- g. Opened or re-stacked panel bundles should be secured to prevent wind damage.

When moving panel bundles, extreme caution should be taken to prevent damage to the panel edges. Uncrated panels should be supported at each end and at 8' spaces.

All bundles or loose panels on the roof should be banded to the roof structurals at the end of each workday. On steep roofs, provisions should be taken to prevent panels and panel crates from sliding off the roof. Be sure to set panel bundles on the roof in the proper direction for the installation sequence.

Trim and accessories should be stored in a secure area and protected from damage, weather, and theft. Fasteners, sealants, closures, etc. should be stored out of the weather and protected from contamination.

### 4.5 HANDLING INDIVIDUAL ROOF PANELS

To lift individual panels, lift one side of the panel by the seam letting it hang naturally to prevent buckling. Pick-up points should not be more than 10' apart. Do not pick-up panels by the ends only, or in a flat position.

If the individual panels are to be lifted to the roof by hand line, the common method is to use the vice grip "C" clamps. Position the clamps on the flat of the panel, as close as possible to one edge so the panel is lifted in a vertical position. The jaws of the vice grips must be padded to prevent damage to the panel surface. The clamps should be uniformly spaced, no more than 10' apart and the hand lines must be pulled in unison so that uneven lifting does not buckle the panel. Be sure the clamps are tight on the panel and the line is secure to prevent dropping the panel, which can result in personal injury and property damage.

## 5.0 ROOF INSTALLATION BASICS

### 5.1 PROPER TOOLS

Before starting paneling, be sure that the proper equipment and tools are on hand. The tools must be in good operating condition and operators should adhere to safety precautions at all times.

Improper operating tools, too few tools, inadequate power source, or other equipment deficiencies slow down the installation process. The cost of inefficient working is usually greater than the cost of providing good equipment.

### 5.2 EQUIPMENT LIST

The following tools and equipment should be considered for efficient installation of the Steelway standing seam panel. Actual tools and equipment required may vary due to variations in building type and construction.

- \*RTL-24 Rib Clamp — Minimum of (3) required (for buildings with one roof splice)
- \*RTL-24 Seam Clamp — Minimum of (2) required (per roof splice)
- \*RTL-24 ModLoc Tool
- \*RTL-24 Motorized Seaming Machine
- \*Hand Crimper Tool
- Screw Guns — Designed for use with self-drilling screws
- Socket Extensions — 6" extension for screw gun
- Hex Socket Heads — 5/16" and 3/8", magnetic
- Drill Motor — 1/4" capacity
- Drill Bits — Assortment
- Sheet Metal Cutter — or power shears or nibbler
- "C" Clamps — vise grip type
- Pop Rivet Tool — 1/8" capacity
- Sheet Metal Shears — left and right cut
- Hack Saw — with metal cutting blade

This list should not be interpreted as a limitation to your inventory of installation equipment.

- Punches
- Steel Measuring Tape — 12', 50', 100'
- Nylon String Lines
- Chalk Line
- Brooms
- Clean, dry cloths
- Plastic coolers for sealants
- Marking Pen
- Caulk Guns — for 1/10 gallon sealant tubes
- Power Source and Extension Cords — capable of handling the total equipment requirements, including 20-amp seamer machine, without power drop due to extension cord length.

\*These tools are specifically designed for the Steelway Roof Panel and are available from Steelway.

### 5.3 SEALANTS

#### A. TEMPERATURE EFFECTS

Temperature extremes must be considered during installation of the roof due to the sensitivity of sealants. The recommended installation temperature range is -7 °C (20 °F) to 49 °C (120 °F). At colder temperatures, the sealant stiffens resulting in loss of adhesion and compressibility. At hotter temperatures, the sealant becomes too soft for practical handling. On cold but sunny days, the panel's surface may become warm enough to accept the application of a heated sealant even though the air temperature is below -7 °C (20 °F). Heated sealant will stay warmer if stored in plastic coolers while working on roof.

## 5.0 ROOF INSTALLATION BASICS

When overnight temperatures fall below freezing, the sealant should be stored in a heated room so it will be warm enough to use the following day. On hot days, the sealant cartons should be stored off the roof in a cool and shaded area. While on the roof, sealant rolls should be kept shaded until actual use. A plastic cooler works well for this purpose.

In very cold weather, it is recommended that the fasteners be tightened slowly and only tight enough that the sealant is in full contact with the panel or flashing. Then on the next sunny day, complete the tightening process after the sun warms the panel and flashing surfaces.

### **B. CONTAMINATION**

To assure proper adhesion and sealing, the sealant must have complete contact with adjoining surfaces. Contaminants such as water (i.e. do not install roof system in the rain), oil, dirt and dust prevent such contact. The panel and flashing surfaces must be dry and thoroughly cleaned of all contaminants. Before applying tape sealant, the sealant should be checked for contaminants. If the sealant surfaces are contaminated, it must not be used.

During cool weather, condensation or light mist can accumulate on the panel and flashing surface and not be easily noticed. It is recommended that sealants always be kept under protective cover and that the panel and flashing surfaces be wiped dry immediately before installation.

Tape sealant is provided with a protective paper to reduce contamination. Incomplete removal of the protective paper will prevent the sealant's adhesion to the panel or flashing surfaces. Always check that the protective paper is completely removed. Do not remove the protective paper until immediately before the panel or flashing is installed over the sealant.

### **C. COMPRESSION**

To assure proper adhesion and seal, the tape sealant must be compressed between the panel and flashing surfaces with firm and uniform pressure. In most cases, the required pressure is applied by the clamping action of screws pulling the adjoining surfaces together. However, the tape sealant's resistance to pressure becomes greater in cold weather.

During cold weather, the fasteners must be tightened slowly to allow the sealant time to compress. If the fasteners are tightened too fast, the fastener may strip out before the sealant compresses adequately, or the panel or flash may deform in the immediate area of the fastener, leaving the rest of the sealant insufficiently compressed.

### **D. INSIDE CORNERS**

An inside radius, such as where the panel flat meets a rib, is usually the most critical area to seal. A common mistake for the installer, is to bridge the sealant across the inside radius.

When the lapping panel or flashing is pushed into place, the bridged sealant is stretched and thinned. The sealant may then be too thin to adequately seal this critical area. When tape sealant is applied at an inside radius, it is recommended that the sealant be folded back on itself, then push the sealant fold into the radius.

## 5.0 ROOF INSTALLATION BASICS

### 5.4 FASTENERS

#### A. SCREW GUN

Use torque control screw guns for driving self-drilling screws. 2000-2500 RPM screw gun speeds are necessary to attain efficient drilling speeds. High tool amperage (4 to 7 AMP) is required to achieve the proper torque for secure fastening.

#### B. SOCKETS

Use good quality magnetic sockets. Good fitting sockets reduce wobble and stripping of the screw heads, especially the alloy and capped heads. They also minimize objectionable paint chipping and scuffing on coloured screws and minimize damage to the protective coating on unpainted screws.

Magnetic sockets collect drill shavings, which will build up and eventually prevent the socket from seating properly on the screw heads. One method of removing the drill shavings is to roll up a ball of tape sealant and push the socket into the sealant.

When the socket is removed from the sealant, most of the drill shavings will remain embedded in the sealant thereby cleaning the socket. This process should be repeated as often as needed to keep the socket clear of drill shavings.

#### C. SOCKET EXTENSION

A 4" or 6" socket extension is recommended for installing the panel clip screws. With the extension the screw can be driven straight down without tilting the screw gun to clear the panel or clip. Since socket extensions are slow to wear out, it is usually more cost effective to purchase socket extensions and good quality sockets rather than purchase sockets with built-in extensions.

#### D. INSTALLATION

Before starting the screw, the materials to be joined must be pressed together with foot or hand pressure. The pressure must be maintained until the screw has drilled through all the materials and the threads have engaged.

Most self-drilling screws require 20 pounds of pressure to maintain the drilling action and to start the thread cutting action. Also, applying such pressure before starting the screw gun will usually prevent tip walking or wandering. If too little pressure is applied, the drill point may not cut into the metal and the point will heat up and become dull. If the pressure is too heavy, the bottom material may be deflected away, causing a standoff condition, or the drill tip may be broken or split. Screws must be held perpendicular to the panel or flashing surface during starting and driving.

For proper seating of the fastener-sealing washer, the panel or flashing surface must be clean and drill shavings must be removed from under washers before seating. The fastener must be driven perpendicular to the panel surface so that the washer can seat level without warping or cupping.

Do not over drive screws. Over driving can strip the threads and/or damage the sealing washer. Use screw gun with torque control set to function properly for the combination of fastener size, hole size and material thickness.

The fastener should be driven tight enough to uniformly compress the washer but not so tight that the washer splits or rolls out from under its metal dome. The recommended procedure is to tighten the fastener until the sealing washer just starts to visually bulge from under the metal dome.

## 5.0 ROOF INSTALLATION BASICS

### D. INSTALLATION (CONT'D)

As a good installation practice, all roof installers should carry approved oversized screws. Upon stripping or breaking a screw, the screw must be immediately removed and replaced with the appropriate oversized screw. Do not defer the screw replacement to be remembered and fixed later, or to be found by the clean-up crew. The majority of such screws will be overlooked until the customer complains of leakage.

## 5.5 FIELD CUTTING PANELS AND FLASHING

### A. ABRASIVE SAW PROBLEMS

Abrasive saws (circular saws with friction disks) are not recommended for cutting roof panels or flashings. Abrasive saws create high heat that may burn away the protective cladding from the panel edge, causing the edge to rust.

Also, abrasive saw dust contains fine, hot steel particles, which accumulate on panel and flashing surfaces where they rust and can cause staining and rusting of those surfaces.

Rust caused by abrasive saw damage or abrasive dust particles may be excluded from warranty claims.

### B. SHEARING METHODS

It is recommended that panels and flashing be cut with shears to provide a clean, undamaged cut. On shear cut edges, the protective cladding extends to the edge of the cut and is often wiped over the edge to further protect the base metal. Whenever possible, fit the material so that the factory cut edge is exposed and the field cut edge is covered.

When field cutting complex shapes, it is usually easier to cut out a 1" wide strip using both left and right hand shears. The 1" cutout provides clearance to smoothly cut the flats and the clearance to work the shears around tight corners.

When making repetitive cuts (such as cutting panels at a hip condition) it is recommended that a template be made from a piece of drop-off panel or flash to provide fast and accurate marking of the field cut.

When using panel material for the template, cut off the top portion of the panel ribs so that the template is easily laid onto the panel being marked.

### C. MARKING PANELS

Avoid marking the panels for cutting, etc., in a manner that will leave visible markings stains, etc., on the finished roof surface. Use chalk or felt tip ink markers.

#### WARNING

**Do not use graphite (lead) pencils on unpainted panel surfaces.** The graphite can cause rusting of the surface.

## 6.0 ROOF PANEL LAYOUT



### 6.1 SHEETING DIRECTION AND MODULARITY

The Steelway roof system is designed so it can be installed on either side of the gable starting at the end indicated on our erection drawings.

The recommended installation sequence is to complete each panel run from eave to ridge before starting the next panel run. This sequence will help ensure straight runs and allow the insulation to be installed immediately ahead of each panel run.

During installation of the roof, considerations must be made for maintaining panel modularity. By maintaining panel modularity, the roof panel sidelap and seam can be properly assembled, the proper roof coverage can be obtained, and the standard perimeter parts will fit properly without necessity of field modifications or reordering of parts, etc.

#### CAUTION

Failure to maintain panel coverage width within the specified tolerance can cause faulty roof panel seams which can result in seaming difficulty, or in severe cases, reduction in roof performance specifications.

The panels must be held to the width dimension of the panel as designated on the erection drawings within a 1/8" width tolerance per panel. The accumulated coverage (start panel to finish panel) tolerance is determined by the ability to keep the panels parallel and to correctly fit and assemble the finish rake condition.

If the roof has conditions such as fixed location penetrations, parapets, fire walls, etc., the accumulated panel coverage may require tighter tolerances for proper fit-up and weather tightness of the roof system.

## 6.0 ROOF PANEL LAYOUT

### 6.2 PANEL NOTCHING

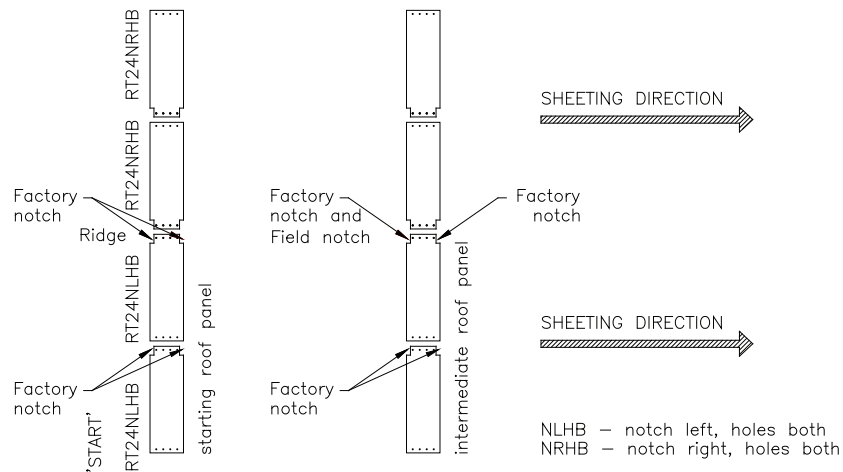

Ensure the correct sheeting direction before starting the roof panel installation. Both factory notches of the panels with the part number RT24NLHB have to be on your left hand side and the panels with the part number RT24NRHB on your right hand side.

Field work is required at all intermediate panels on the female seam at the ridge. For proper alignment it is important to notch the panel. **Do not bend the female seam over the male seam.**

### 6.3 LAYOUT & CHECKING FOR COVERAGE

Recommended for all roofs, but a must for large or complex roofs, is to make a layout of the actual structure (field measured as described in section 3.3) so that the roof panel start and stop dimensions can be laid out to accommodate any structural misalignments.

When the optimal start and finish dimensions are determined, a string line should be set to precisely locate the leading edge of the start panel. After the start panel is secured and engaged with the next panel, the start panel seam will be the reference line for checking accumulated panel coverage.

Panel coverage is always checked at the eave, ridge, and end splices so that non-parallel seam (or dogleg) conditions can be detected and corrected before they become objectionable. The coverage check should be done with a measuring tape held taut and measured to the same side of the seam and always parallel to the eave to prevent any measuring error.

Every four to six panel runs should be checked for panel modularity. This will assure that the panels are maintaining a straight line and proper coverage is being maintained. If the panels are off module, they should be corrected by equal adjustments of the next four to six panel runs.

### 6.4 APPEARANCE CONSIDERATIONS

Although the above stated coverage tolerance will provide for reasonable ease of installation and water tightness, such visible conditions as non-parallel panel seams, dogleg of the panel seam at the end splices, non-parallel finish panel width, and mismatch of panel seams across the ridge, may be objectionable and should be confirmed with the customer before continuing roof installation.

## 7.0 INSPECTION OF ROOF ASSEMBLY DURING INSTALLATION

### 7.1 IMPORTANCE OF INSPECTION

During the roof installation, all areas of the roof system assembly must be frequently inspected to ensure the correct assembly in accordance with the erection drawings and this installation guide.

Failure to assemble the roof system correctly will result in roof performance problems that may require costly corrective work, roof replacement and performance and damage claims etc. Also, incorrect installation may void the performance and material warranties.

### 7.2 INSPECTION LIST

#### A. ERECTION DRAWINGS

- Check that the erection drawings are available at the job site and have been reviewed for differences with the actual job conditions and differences with the installation guide. Also, confirm that the drawings are the latest issue with the latest revisions and additions.

#### B. ROOF LAYOUTS

- Check that the roof start and finish dimensions have been correctly determined based on the erection drawings and the actual structural conditions.

#### C. BEFORE INSTALLING ROOF PANELS

- Check that the structural misalignments were corrected in accordance with Section 3.0 of this installation guide.
- Check that the correct eave and gable angels are in place before installing the roof panels.
- Check that the roof panel elevation provided by the panel clip height and insulation system matches the eave and rake plate elevation.

#### D. PANEL LENGTH

- Check that the installed roof panels have the correct overhang at the eave and endlaps and have the correct hold back at the ridge or high eave, in accordance with the erection drawing.

#### E. EAVE SEAL

- Check that the eave sealant is in the correct position on top of the eave trim and that the corrugation closure and eave pigtail sealant are correctly placed. Check that the eave fasteners penetrate the center of the eave sealant and into the eave trim. Check that the fasteners are not loose or stripped.
- Check that the eave sealant is in complete contact with the roof panel and eave trim without any voids or gaps. Confirm that the roof panel and eave trim are clean and dry during installation and that the sealant is not wet or otherwise contaminated.

#### F. ENDLAP SEAL

- Check that the roof panel endlaps are correctly assembled and that the lapping panels are tightly nested without visible gaps.
- Check that the sealant is in the correct position and is in complete contact with the lapped panels without any voids or gaps, especially at the radius between the panel flat and the vertical legs of the panel. Confirm that the panels are clean and dry during installation and that the sealant is not wet or otherwise contaminated.
- Check that the pigtail caulking is in the correct position and seals the endlap seam notches.
- Check that the cinch strap fasteners penetrate through the center of the sealant and into the back-up channel. Check that the fasteners are not loose or stripped.
- Check that the endlap assembly is not bowed down causing water ponding and debris accumulations.

## 7.0 INSPECTION OF ROOF ASSEMBLY DURING INSTALLATION

### G. RIDGE SEAL

- Check that the ridge closure assembly is correctly assembled.
- Check that the sealant is in the correct position and is in complete contact with the closure and the roof panel without any voids or gaps. Confirm that the closures and roof panels are clean and dry during installation and the sealant is not wet or contaminated.
- Check that the closure fasteners penetrate through the center of the sealant and into the back-up channel.
- Check that the fasteners are not loose or stripped.
- Check that the tube sealant is installed along the back of the closure as necessary to seal any voids around the panel seam area.

### H. GABLE SEAL

- Check that the termination zee is correctly assembled with the termination zee splices correctly oriented for downhill watershed.
- If there are roof panel endlaps, check that the endlap sealant contacts the termination zee sealant or that a pigtail sealant is applied for that purpose.
- Check that the sealant is in the correct position above and below the roof panel.
- Check that the termination zee sits fully on the sealant and that the sealant is in complete contact with the roof panel and the zee without any voids or gaps. Confirm that the roof panel and zee are clean and dry during installation and that the sealant was not wet or contaminated.
- Check that the termination zee fasteners penetrate the center of the sealant and into the zee plate.
- Check that the fasteners are not loose or stripped.

### I. PANEL CLIP ATTACHMENT

- Check that there is mastic on each clip. If a clip doesn't have mastic, do not use.
- Check that the panel clips are correctly fitted to the panel without any distortion or damage of the clip tab. On sliding clips, check that the clip tab is centered on the clip base between the centering tabs.
- Check that the clips are located along each panel sidelap at each roof purlin (structure) or at the locations specified on the erection drawings.
- Check that the panel clip fasteners are of the type, size, length, finish and quantity-per-clip as specified on the erection drawings.
- Check that the panel clip fasteners are not loose or stripped. In the case of multi-layered construction, verify that the fasteners penetrated and engaged the specified structural member.

### J. SIDELAP

- Check that the panel sidelaps are on module (held to within the 1/8" panel width tolerance) and are assembled so that the male and female panel edges and panel clips are properly nested together prior to seaming.
- Check that the full length of each sidelap seam is correctly seamed.
- Check that the factory installed sidelap sealant is in the correct position without voids or interruptions and is not damaged, wet or otherwise contaminated.
- Check that the panel coverage tolerance does not exceed 1/8" per panel and that the accumulated coverage will allow proper fit and assembly of the end dams and finish rake condition and any other critical fit conditions such as penetrations, parapets, etc.

### K. FLASHING AND PENETRATIONS

- Check that all flashings (including penetrations) are correctly assembled and tightly fitted. Check that the required sealants are correctly positioned and in complete contact with the adjoining surfaces without voids or interruptions. Confirm that the sealants and adjoining surfaces are clean and dry during installation.

## 7.0 INSPECTION OF ROOF ASSEMBLY DURING INSTALLATION

- Check that the flashing splices are correctly lapped, sealed and fastened.
- Check that the flashing is sufficiently pitched to shed water and eliminate ponding areas, especially at the critical splices, endlaps and corners.
- Check that the fasteners are of the specified type, size, length, finish and spacing. Check that the fasteners are not loose or stripped. Check that the sealing washers are in full contact with the flashing surface and not distorted, split or otherwise damaged.
- Along the gable, high eave transitions, fixed penetrations, etc., check that the flashing is not constrained and will allow for the roof's expansion/contraction movement.

### L. SURFACE CONDITIONS

Damaged roof system surfaces are subject to corrosion and performance problems and may void the material and performance warranties.

- Check that the panel and flashing surfaces are not being subjected to abusive conditions such as: careless handling of panels and flashing, excessive roof traffic, abrasive or contaminated footwear, rough handling of materials, tools and equipment, or contact with abrasive materials or residue, etc.
- Check that the panel and flashing surfaces are not being subjected to exposed metal objects and materials left on the roof such as: tools, material drop-off, fasteners, wire, staples, drill and nibbler chips, saw and file particles, etc. In the process of rusting, these materials will absorb the panel's protective coating, thus leaving the panels exposed to rusting.
- Check that the panels and flashing are not being subjected to long term wet conditions such as: standing water, consistent sources of steam, mist, spray, dripping or runoff, wet debris, wet insulation or other moisture holding material.
- Check that the panels and flashing are not subjected to direct contact or runoff from corrosive materials such as: galvanized materials, copper pipes and flashing, uncured cement, treated lumber, anti-icing chemicals, strong solvents or other corrosive materials.
- Check that graphite pencils were not used to mark on unpainted surfaces. The graphite marks can cause rusting.
- Check that the roof materials are not subjected to damaging heat such as: cutting torches, abrasive saws, etc.

### M. UNSPECIFIED/INCOMPATIBLE MATERIALS

Use of the wrong materials may cause installation and performance problems and may void the performance and material warranties.

Do not use galvanized products, such as roof curbs, on any roof system supplied by Steelway.

Drains from A/C roof units **must not** be made of copper pipe. Only plastic drain pipes are permitted. Plastic drain pipes should extend down roof and directly into eave gutter (if provided). Run-off through or over copper pipes will corrode metal roofing.

- Check that all installed roof system materials, especially sealants and fasteners, are only those which are provided or specified by Steelway for your specific project and are used only as specified on the erection drawings and this installation guide.

**Do not** use Silicon based caulking on roof system or trims. Silicon will corrode metal products.

Steelway cannot be responsible for the performance of roof materials that are not provided, specified or approved by Steelway.

## 8.0 STANDARD PARTS



### 8.1 GENERAL

The following details provide a basic description and graphic illustrations of the standard roof assembly parts. The purpose of these details is to assist the erector in the correct selection and identification of parts.

Because of the many variations in conditions, it is important that you review the job conditions to identify the specific parts required for your job.

Review the erection drawings for any special parts or parts which are different from the standard parts shown in these details. If differences exist, the erection drawings will have precedence.

For proper fit-up, sealing and fastening, and to help ensure the roof assembly's weather tightness, structural capability, durability and appearance, the correct parts must be used. Do not use parts other than those specified on the erection drawings.

## 8.0 STANDARD PARTS

### 8.2 ROOF PANELS & CLOSURES

- METAL VOID CLOSURE
- 22 gauge Steel
  - Galvanized Finish
  - Factory punched hole

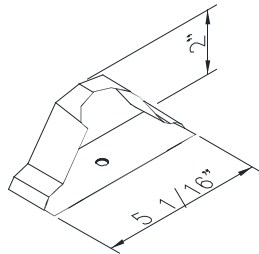

Part No. CC200

- CLOSURE CLIP
- 24 gauge Steel
  - Galvanized Finish

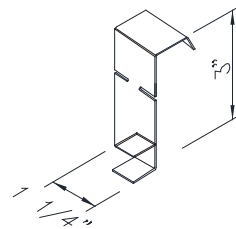

Part No. CC300

- ROOF PANEL (24" wide panel)
- 24 or 22 gauge Steel
  - Painted or Galvalume Plus Finish
  - Factory notched for endlap
  - Factory punched holes

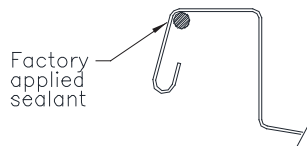

Part No. RTL-24

- END DAM (for 24" wide panel)
- 24 gauge Steel
  - Galvanized Finish
  - Factory punched holes

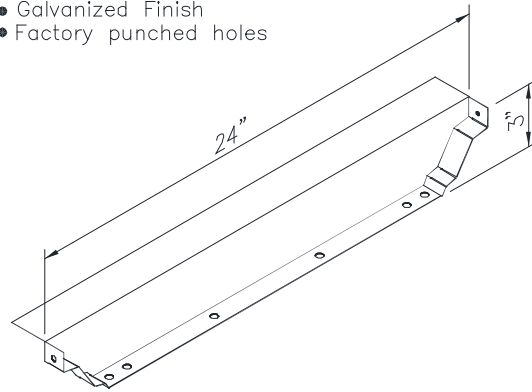

Part No. ED124

- HIGH EAVE/RIDGE BACK-UP PLATE
- 16 ga. Galvanized Steel
  - Factory punched holes

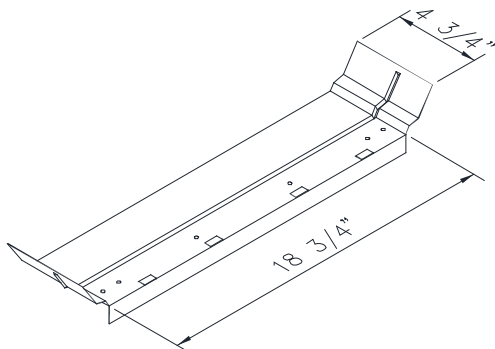

Part No. BP124

- ENDLAP BACK-UP PLATE
- 16 ga. Galvalume Steel
  - Factory punched holes
  - 1/2" & 1 1/2" Stand-off

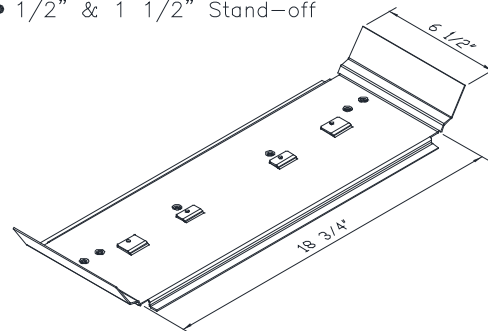

Part No. BP2-324

## 8.0 STANDARD PARTS

### 8.3 PANEL CLIPS, GUTTER BRACKET & ENDLAP & TERMINATION PARTS

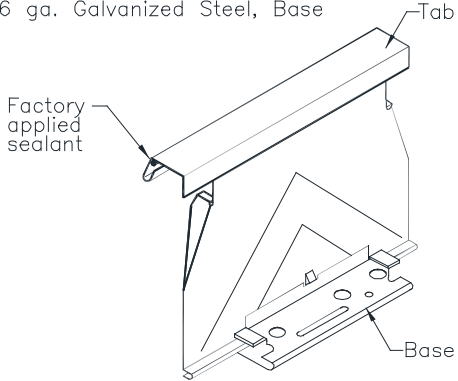
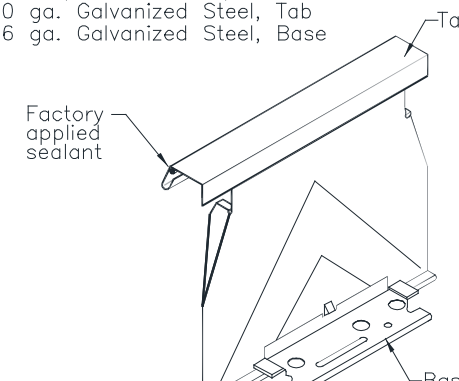
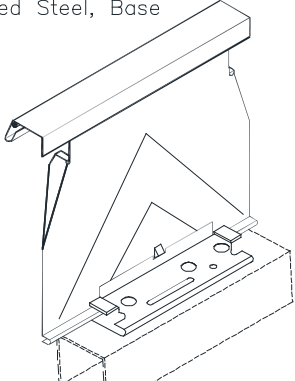
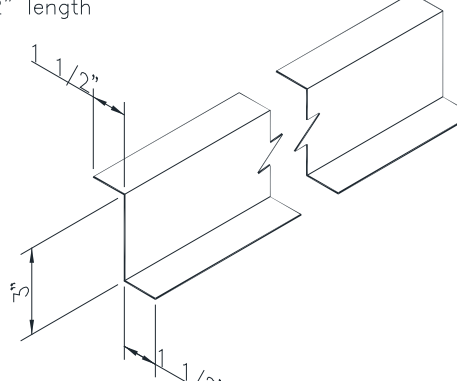
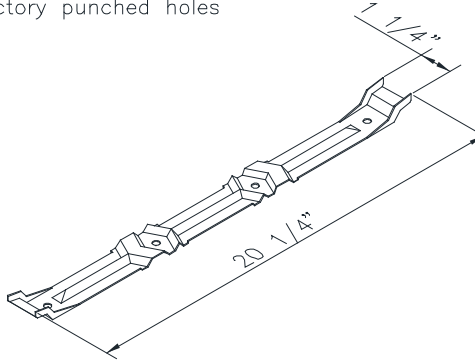
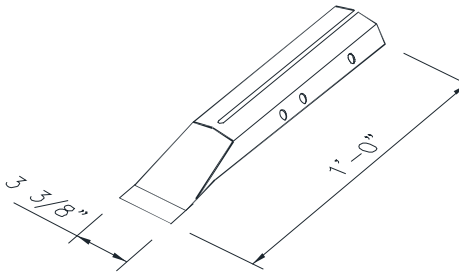
<p>PURLIN FLOATING CLIP (3") (for 3/8" stand-off)</p> <ul style="list-style-type: none"> <li>• 20 ga. Galvanized Steel, Tab</li> <li>• 16 ga. Galvanized Steel, Base</li> </ul>  <p>Part No. RT304FL</p>	<p>PURLIN FLOATING CLIP (4") (for 1 3/8" stand-off)</p> <ul style="list-style-type: none"> <li>• 20 ga. Galvanized Steel, Tab</li> <li>• 16 ga. Galvanized Steel, Base</li> </ul>  <p>Part No. RT404FL</p>
<p>PURLIN FLOATING CLIP (6") (for 3 1/4" stand-off)</p> <ul style="list-style-type: none"> <li>• 20 ga. Galvanized Steel, Tab</li> <li>• 16 ga. Galvanized Steel, Base</li> </ul>  <p>Part No. RT604FL</p>	<p>TERMINATION ZEE</p> <ul style="list-style-type: none"> <li>• 20 ga. Galvalume Steel</li> <li>• 20'-2" length</li> </ul>  <p>Part No. RZ242</p>
<p>ENDLAP CINCH STRAP (for 24" wide panel)</p> <ul style="list-style-type: none"> <li>• 18 gauge Stainless Steel</li> <li>• Factory punched holes</li> </ul>  <p>Part No. RTCS24</p>	<p>Gutter Bracket</p> <ul style="list-style-type: none"> <li>• 20 ga. Galvanized Steel</li> </ul>  <p>Part No. RTGB200</p>

## 8.0 STANDARD PARTS

### 8.4 EAVE/GABLE PLATES & SPACER BLOCKS

- EAVE PLATE (for 3/8" stand-off)
- 16 ga., 50 ksi Galvalume Steel
  - 4'-0" length
  - Factory punched holes

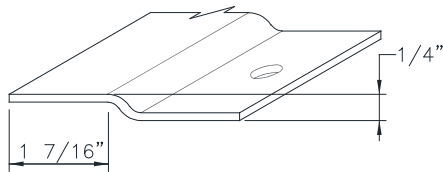

Part No. EP140

- RAKE PLATE (for 3/8" stand-off)
- 16 ga., 50 ksi Galvanized Steel
  - 10'-0" length
  - Factory punched slots

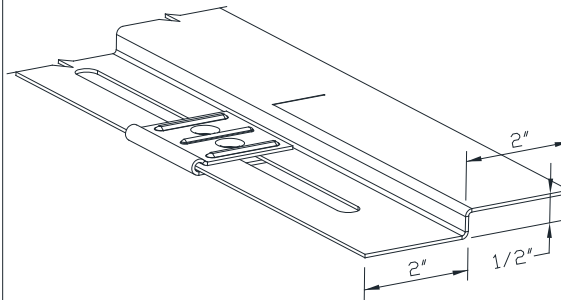

Part No. RKP150

- EAVE PLATE (for 1 3/8" stand-off)
- 16 ga., 50 ksi Galvalume Steel Min.
  - 4'-0" length
  - Factory punched holes

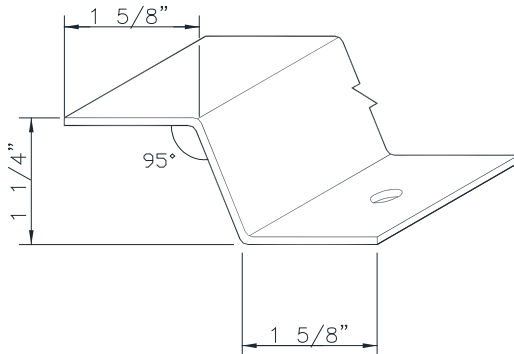

Part No. EP240

- RAKE PLATE (for 1 3/8" stand-off)
- 16 ga., 50 ksi Galvanized Steel
  - 10'-0" length
  - Factory punched slots

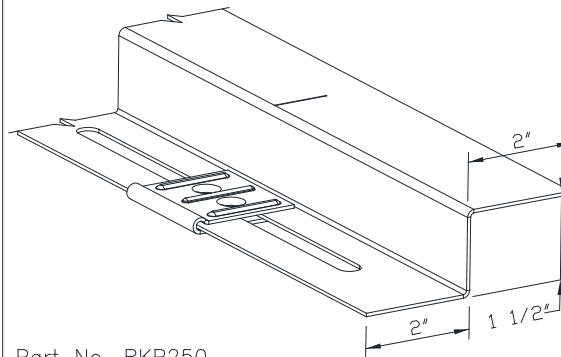

Part No. RKP250

- THERMAL BLOCK (for 24" wide panel)
- Extruded Polystyrene Foam
  - 1" Thick

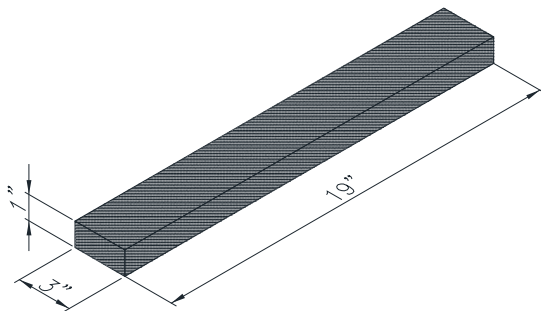

Part No. TB100

## 8.0 STANDARD PARTS

### 8.5 FASTENERS

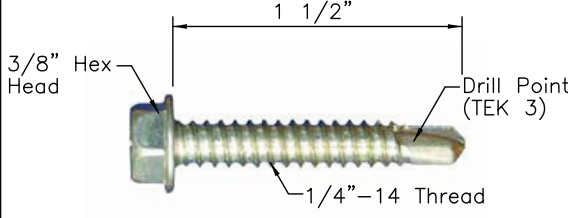
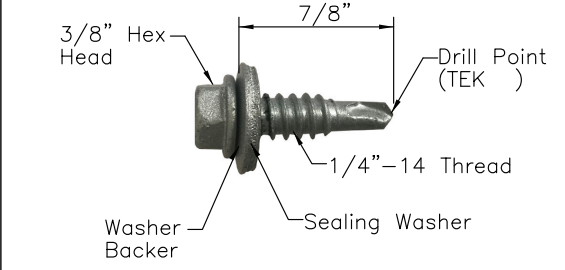
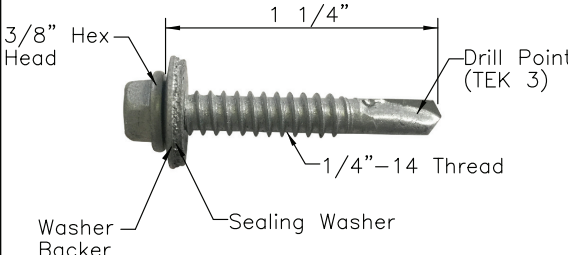
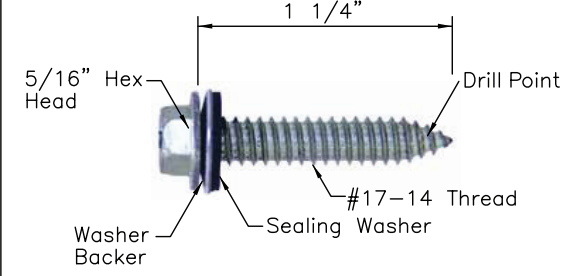
<p>FLOATING CLIP FASTENER/CLIP FASTENER (for purlin floating clip attachment/termination zee &amp; eave/gable plate attachment to steel purlins)</p> <ul style="list-style-type: none"> <li>• 1/4"–14 x 1 1/2", hex head, Self Drilling Screw</li> <li>• Corrosion resistant plating</li> </ul>  <p>Part No. SMS-17</p>	<p>ROOF/ TRIM FASTENER (for panel endlap attachment)</p> <ul style="list-style-type: none"> <li>• #14–14x7/8" Self Tapping Screw</li> <li>• EPDM Sealing Washer</li> <li>• Corrosion resistant coating or alloy head</li> <li>• Painted or mill finished head</li> </ul>  <p>Part No. SMS-41</p>
<p>ROOF/ ENDLAP FASTENER (for panel endlap attachment)</p> <ul style="list-style-type: none"> <li>• #14–14x1 1/4" Self Tapping Screw</li> <li>• EPDM Sealing Washer</li> <li>• Corrosion resistant coating or alloy head</li> <li>• Painted or mill finished head</li> </ul>  <p>Part No. SMS-49</p>	<p>ROOF FASTENER (for panel splice)</p> <ul style="list-style-type: none"> <li>• #17–14 x 1 1/4" hex head, Self Drilling Screw</li> <li>• EPDM Sealing Washer</li> <li>• zinc plated steel</li> </ul>  <p>Part No. SMS-56</p>

## 8.0 STANDARD PARTS

### 8.6 FASTENERS & SEALANTS

ROOF CAULKING  
(for eaves, ridge, gables & trims)  
 • 3/16" x 7/8" Butyl Tape Sealant  
 • 40' Roll

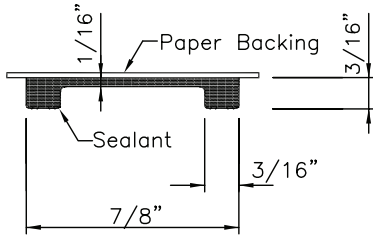

Part No. CLK-10A

BLIND RIVET (optional – not by Steelway)  
(for flashing joints)  
 • Stainless steel  
 • 1/8" dia. x 3/16" length

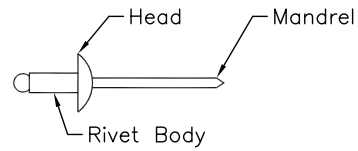

Part No. RF4

ROOF CAULKING  
(for roof splices)  
 • 3/16" x 1 1/4" Butyl Tape Sealant  
 • 30 1/2" Strip

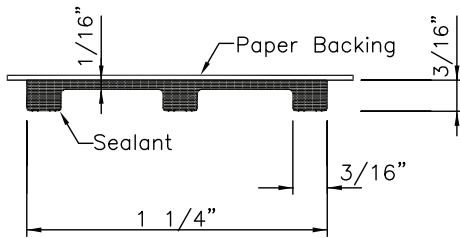

Part No. CLK-125

TUBE SEALANT  
 • Urethane Gun Grade Sealant  
 • Color-grey  
 • 300 mL. Tubes

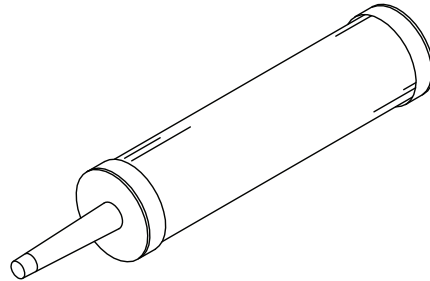

Part No. TC200

## 9.0 ROOF INSTALLATION DETAILS



### 9.1.1 GENERAL

The following details provide graphic illustration of the roof assembly steps. The purpose is to instruct the erector in correct and efficient assembly of the roof system.

Because of the many variations in conditions, it is important that you review the job to identify and isolate the specific installation details required for your job.

Review the erection drawings for differences with these details. If differences exist, the erection drawings have precedence.

These details are arranged in a step-by-step sequence. Following this sequence ensures correct assembly and ensures that the part to be worked on will be readily accessible for the next assembly step.

Do not shortcut these assembly steps without careful consideration of the possibility of incorrect or omitted assembly and the resulting corrective rework.

To minimize confusion, the details are always oriented so that the view is from eave to ridge, with the starting gable at the left and finish gable at the right. Refer to the erection drawings to determine the required sheeting direction and gable conditions.

To help ensure weather tightness, the details emphasize proper fit-up, sealing and fastening. It is most important that only the specified sealants and fasteners be used for each condition and that they are installed correctly as shown on these details and the erection drawings.

Be sure that these critical instructions are reviewed often and the roof assembly is checked at each assembly step.

It is strongly recommended that the same people on your crew install eave, endlap (splice) and ridge details (i.e. you would have one person always work at the eave, another person at the splice and another person at the ridge). This way they become experts on that detail which will improve installation quality and reduce installation time.

## 9.0 ROOF INSTALLATION DETAILS

### 9.2 PREPARATION FOR ROOF PANEL INSTALLATION

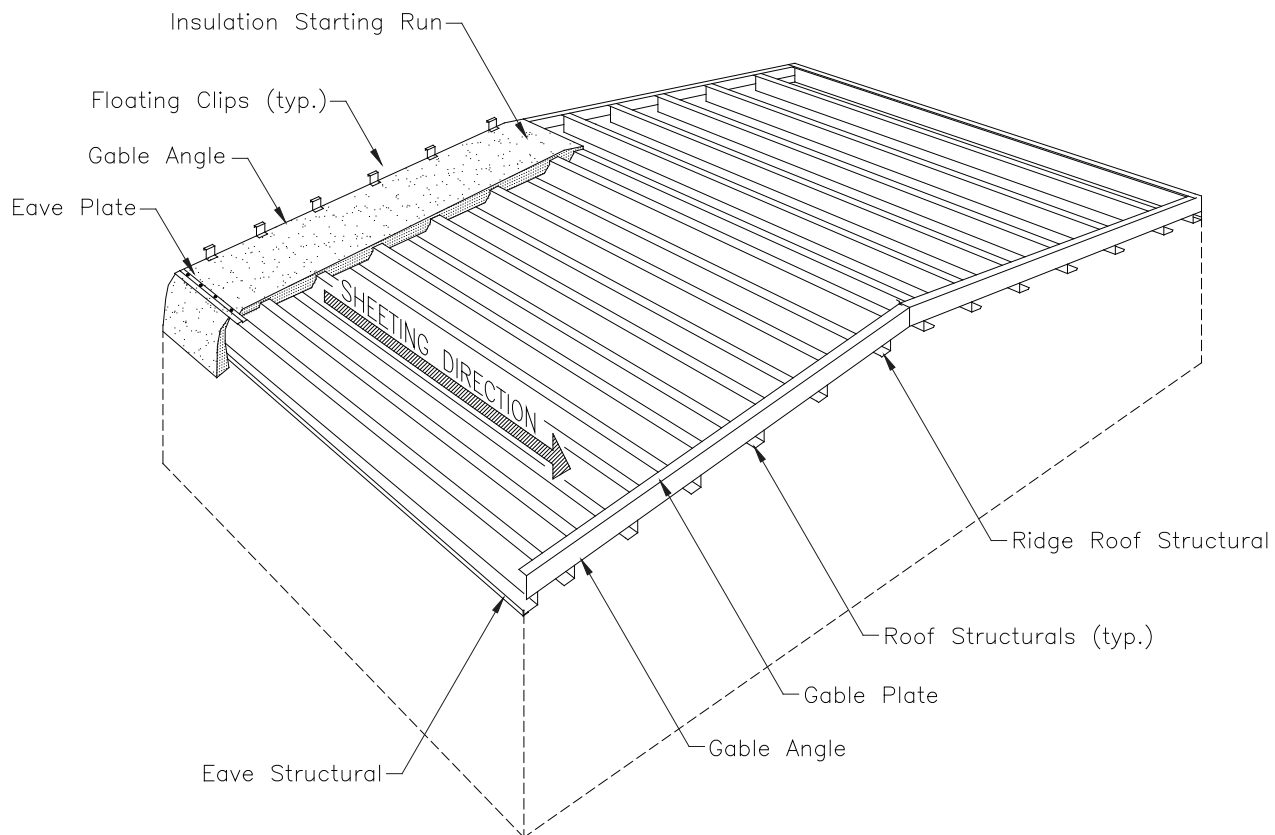

#### 9.2.1 ORIENTATION VIEW

The details in this section will show the installation of the eave plate, floating clips and the first run of insulation. These are parts that must be installed before the roof panel installation can begin.

This view shows the roof system oriented for a left-to-right sheeting direction. For right-to-left sheeting, reverse the parts orientation.

On this view, the starting gable is shown with floating clips (for a starting panel) and the finish gable will have the gable plates and termination zees. Some buildings may require gable plates and termination zees at the starting gable. Refer to the erection drawings for the required gable conditions.

Although not required, it is recommended that you field pre-drill clip holes on 24" o/c at endlaps (splices) and ridge (high eave). This can easily be done once the building is plumb and square and all start clips have been installed. This method will greatly improve modularity and ultimately save you time during panel installation.

## 9.0 ROOF INSTALLATION DETAILS

### 9.2 PREPARATION FOR ROOF PANEL INSTALLATION

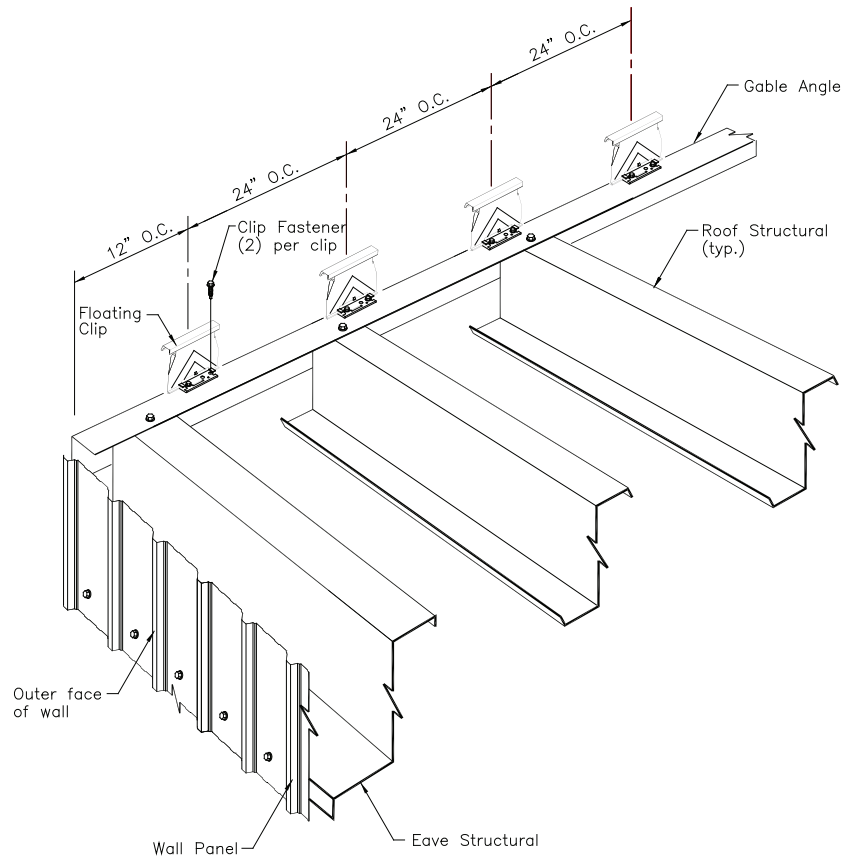

#### 9.2.2 INSTALL START CLIPS

Refer to the erection drawings and the structural layout (as described in Section 6.2) to determine the sheeting direction.

The position of the floating clips establishes the starting roof panel alignment. It is very important that the floating clips are installed in a straight line, parallel to the gable line.

Before installing the floating clips, check that the eave structural members are in a straight alignment from gable to gable.

If the gable angles have been installed true and square, the edge of the gable angle can be used to align the floating clips. If the gable angle is not true and square, a chalk line should be used to guide the installation of the floating clips.

Locate the floating clips at the spacing shown and fasten to the gable angle as shown.

## 9.0 ROOF INSTALLATION DETAILS

### 9.2 PREPARATION FOR ROOF PANEL INSTALLATION

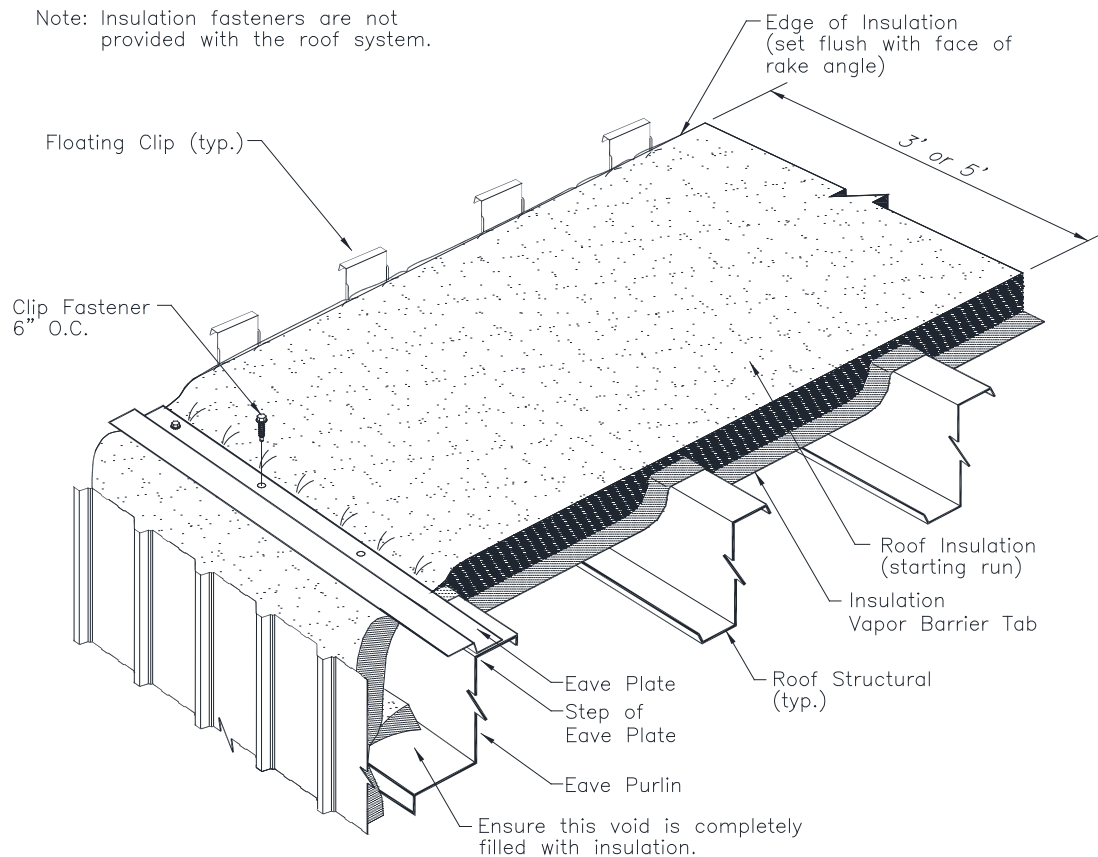

#### 9.2.3 INSTALL STARTER RUN OF INSULATION

Refer to the insulation manufacturer's instructions for proper insulation installation and vapor seal assembly. This detail shows fiberglass blanket insulation, which is the most commonly used insulation for metal standing seam roofs.

The leading edge of each insulation run should extend approx. 12" beyond the leading edge of the roof panel. This will allow for easy assembly of the vapor barrier seal between insulation runs.

With four foot or six foot wide insulation, the first run should be installed to only cover three feet or five feet respectively. The extra foot of width can be cut or lapped over the gable.

Use double-faced tape along the backside of the eave strut and along the gable angle to hold the insulation in place until the roof panel is installed.

In all cases extend the end of the insulation behind the wall panels. Install eave plate as shown on next page to keep the insulation in place.

## 9.0 ROOF INSTALLATION DETAILS

### 9.2 PREPARATION FOR ROOF PANEL INSTALLATION

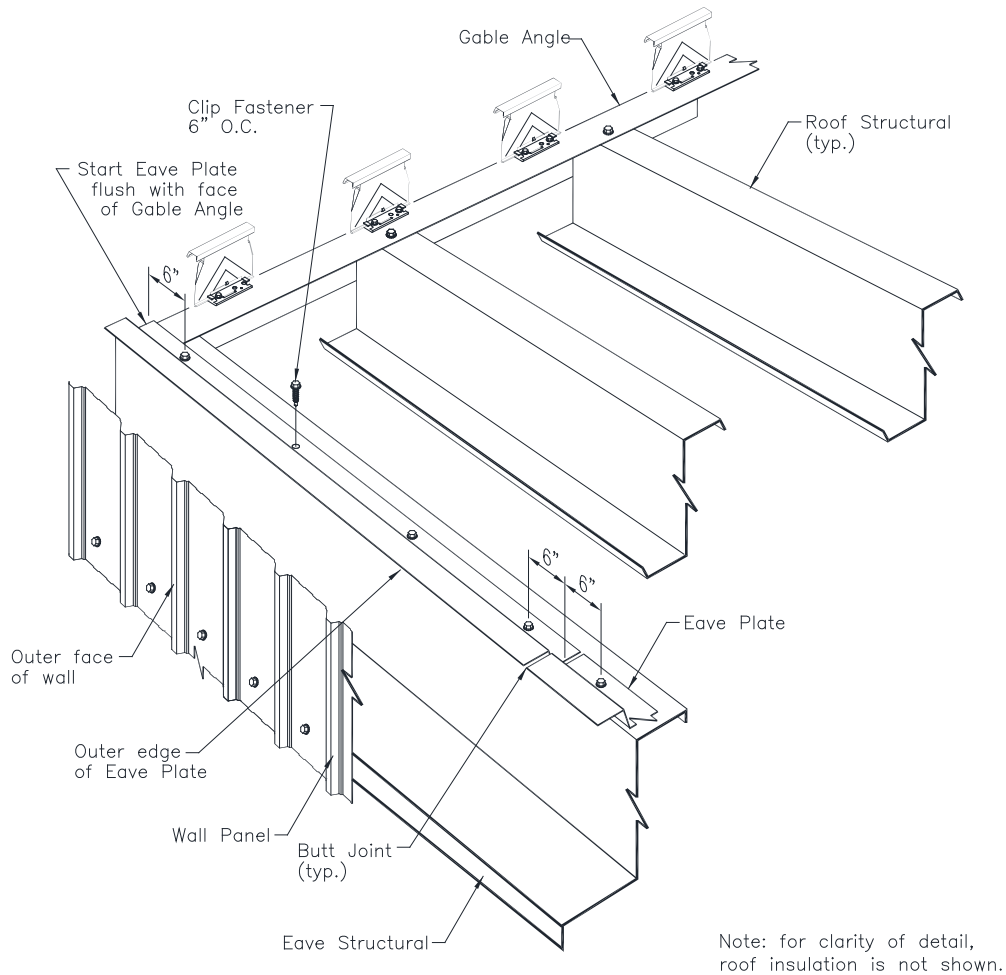

#### 9.2.4 INSTALL EAVE PLATES

The eave plate provides a solid attachment surface for the eave end of the roof panel.

The roof insulation must be placed over the structurals before the eave plate is installed.

Install the starting and finish ends of the eave plates flush with outer face of gable angle.

Tightly butt join the eave plates and fasten to the eave structural as shown.

## 9.0 ROOF INSTALLATION DETAILS

### 9.3 ROOF PANEL INSTALLATION

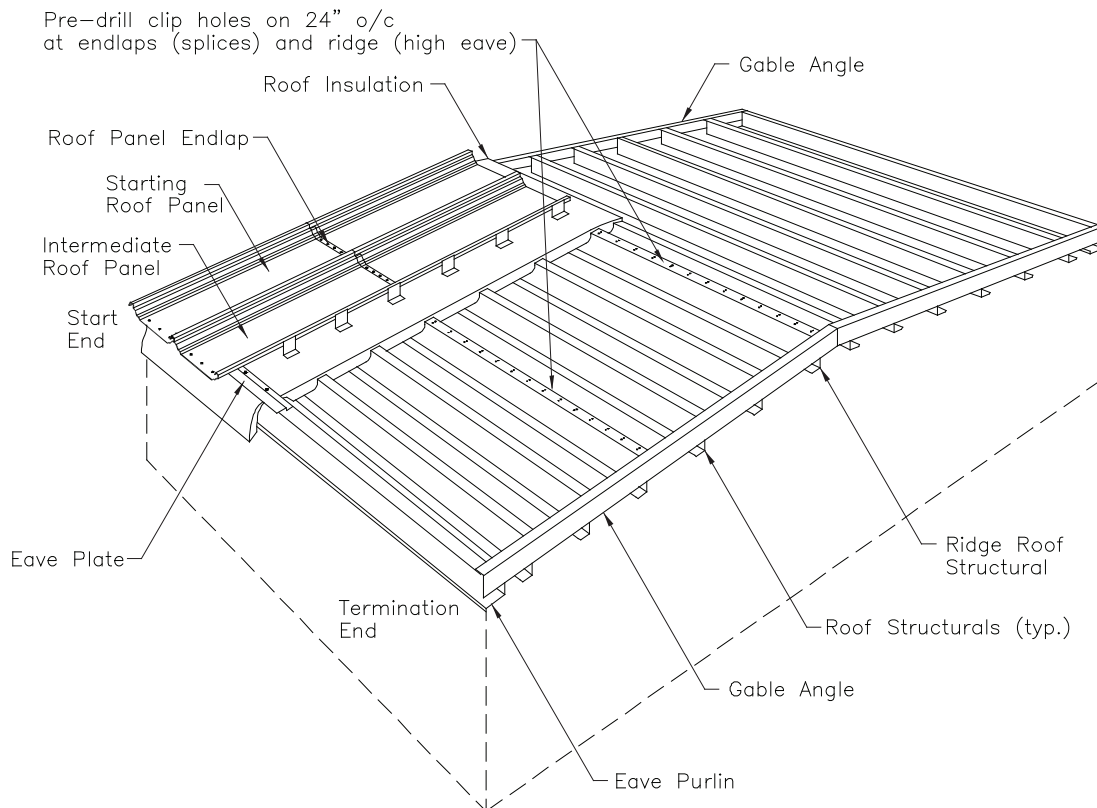

#### 9.3.1 ORIENTATION VIEW

The details in this section show the installation of the starting and termination roof panels. Check erection drawings to determine start end. Sheeting can be done on both sides of the ridge from the start end.

The roof panel endlap details are shown as an integral part of the roof panel installation. If the project does not require roof panel endlaps, the endlap details are clearly identified and can be disregarded.

The termination roof panels require specific installation and are shown in a later section.

Although not required, it is recommended that you field pre-drill clip holes on 24" o/c at endlaps (splices) and ridge (high eave). This can easily be done once the building is plumb and square and all start clips have been installed.

## 9.0 ROOF INSTALLATION DETAILS

### 9.3 ROOF PANEL INSTALLATION

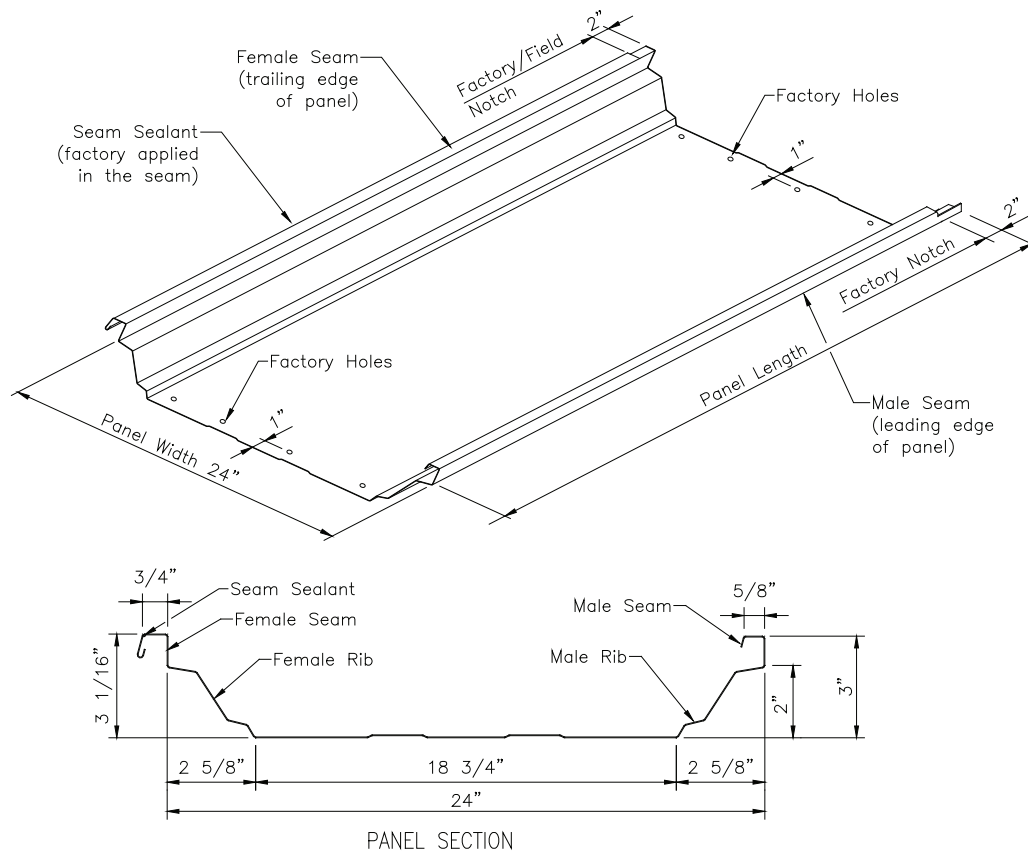

#### 9.3.2 ROOF PANEL DESCRIPTION & NOMENCLATURE

Throughout these instructions the references to the panel will be made using the terms shown on the above illustration.

The Steelway roof panel is designed, so it can be installed on either side of the gable starting at the end indicated on our erection drawings.

The leading edge of the roof panel is the edge towards the sheeting direction. On the Steelway roof panel, the male seam is always the leading edge.

Before loading the panels onto the roof structurals, orient the panels so that the male seam is the leading edge.

## 9.0 ROOF INSTALLATION DETAILS

### 9.3 ROOF PANEL INSTALLATION

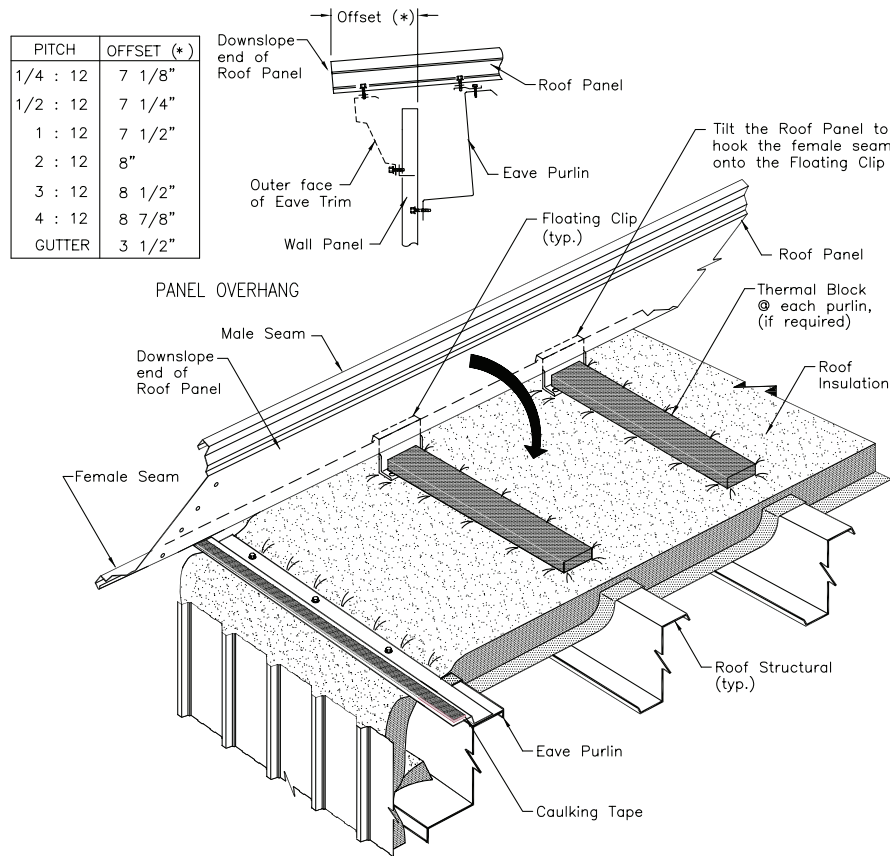

#### 9.3.3 INSTALL STARTING ROOF PANEL

The roof panel's eave overhang dimension is critical as it establishes the location of endlaps and ridge cover attachment points.

The end of the roof panel extends beyond the girt line. The dimension depends on the pitch as shown in the above illustration and on the erection drawings.

If insulation thermal blocks are required, place the blocks on top of the insulation directly over the roof structurals. Thermal blocks are not required at the eave structural.

Position the female edge of the panel over the floating clips and double check the eave overhang dimensions.

Tilt the panel as shown so the female seam can be hooked over the floating clips. Check that each clip is hooked inside of the seam.

Ensure all roof sheets have factory applied sealant in the female seam. If it doesn't have any or is missing at any locations **do not install** roof panels and contact your Project Manager immediately.

## 9.0 ROOF INSTALLATION DETAILS

### 9.3 ROOF PANEL INSTALLATION

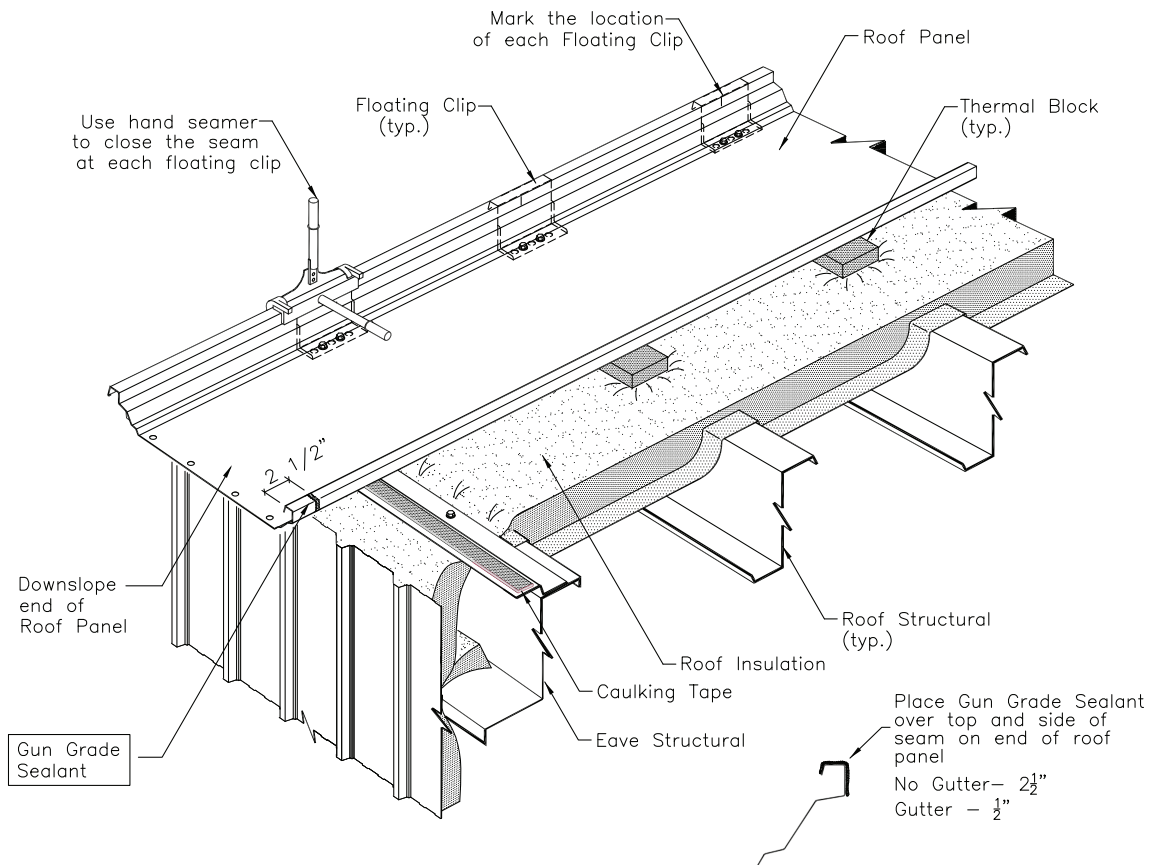

#### 9.3.4 SEAM ROOF PANEL TO START CLIPS

Rotate the panel down to rest on the thermal blocks or insulation.

Verify that the roof panel's overhang dimension is correct and verify that the roof panel is aligned parallel to the gable line.

Ensure start clips are centered on bottom tab. Installation and adjustment of first panel can cause the upper portion of the start clips to move off center.

Using the hand seaming tool, close the panel seam over each floating clip. For proper operation of the seaming tool, refer to the Seaming Instructions section.

Mark the roof panel's vertical leg at each clip location. This will guide the later installation of gable trim fasteners.

Before installing the next panel provide gun grade sealant at eave closure clip location as shown above.

## 9.0 ROOF INSTALLATION DETAILS

### 9.3 ROOF PANEL INSTALLATION - WITHOUT GUTTER

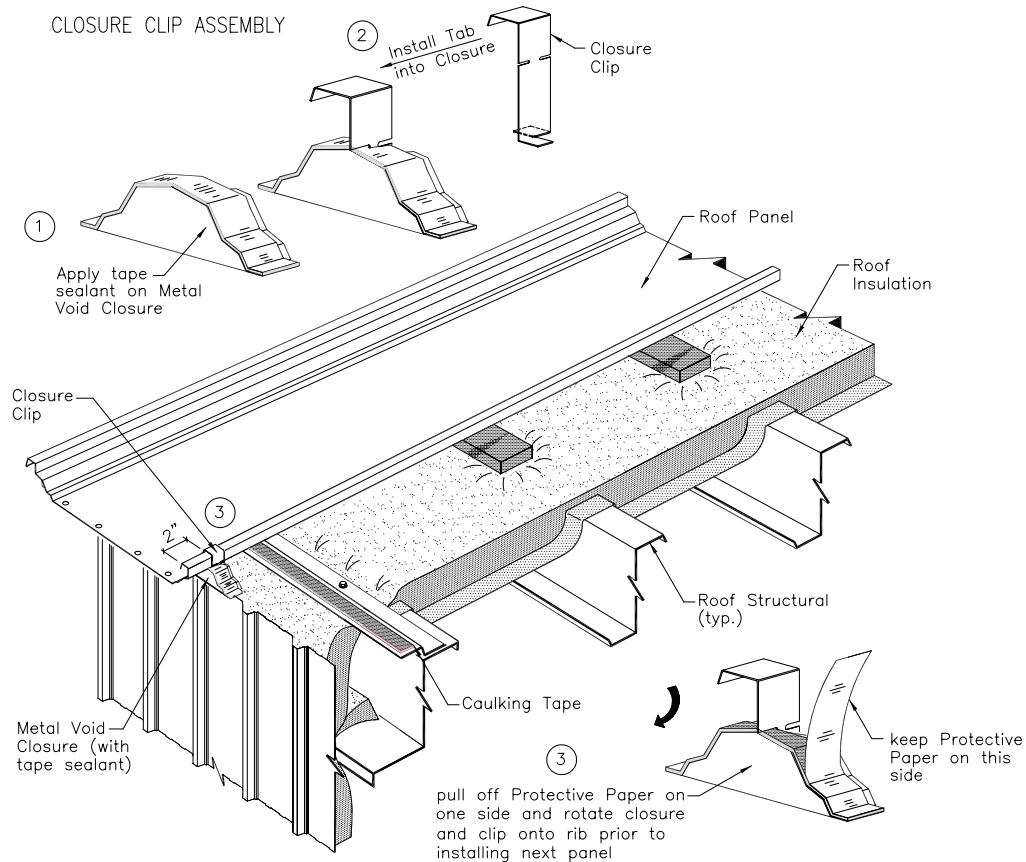

#### 9.3.5 INSTALL EAVE CLOSURE

Prepare the metal void closures by applying caulking tape along the top surfaces and install Closure Clip into closure as shown in the above illustration.

Peel back the protective paper from one side and rotate closure and clip onto prepared rib as shown.

Place the closure 2" beyond the leading edge of roof panel.

Check that the closure is centered to the roof panel's edge.

Pull off the other half of the protective paper before installing the next panel.

Keep heated sealants warmer in the winter or cooler in the summer by storing them in plastic coolers while working on the roof.

## 9.0 ROOF INSTALLATION DETAILS

### 9.3 ROOF PANEL INSTALLATION - WITHOUT GUTTER

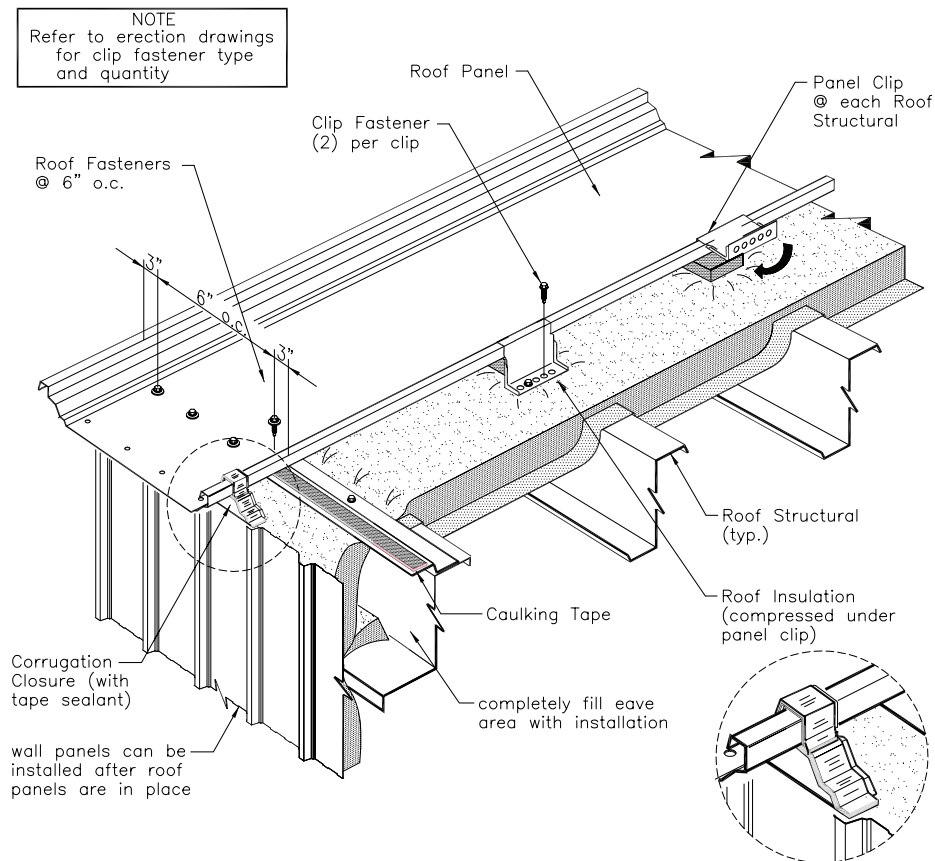

#### 9.3.6 ATTACH ROOF PANEL

Before fastening the roof panel to the eave plate and fastening the leading edge of the panel with the panel clips, check that the panel coverage is correct and the leading edge of the panel is straight and parallel to the gable line.

Fasten the panel with (4) roof fasteners spaced 6" O.C. as shown. Position the fasteners to penetrate into the eave plate.

Prepare tape sealant on Closure Clip as shown in the above detail. See page 9-25 for eave pigtail sealant detail.

Install roof panel clips to the leading edge of the roof panel at each roof structural. Panel clips are not required at the eave structural. Ensure all clips have factory applied sealant.

To install the clips, tilt the clip so that its tab can be hooked over the edge of the roof panel's male seam, then rotate the clip down into the vertical position. Position the clip's base so that the clip fasteners can be installed through the holes in the base and into the roof structural.

When fibreglass roof insulation is used, the panel clips normally sit on top of the insulation and the insulation is compressed between the clip's base and the top of the roof structural. In all cases, refer to the erection drawings to determine the required insulation assembly and the relationship of the panel clips to the insulation.

## 9.0 ROOF INSTALLATION DETAILS

### 9.3 ROOF PANEL INSTALLATION - WITH GUTTER

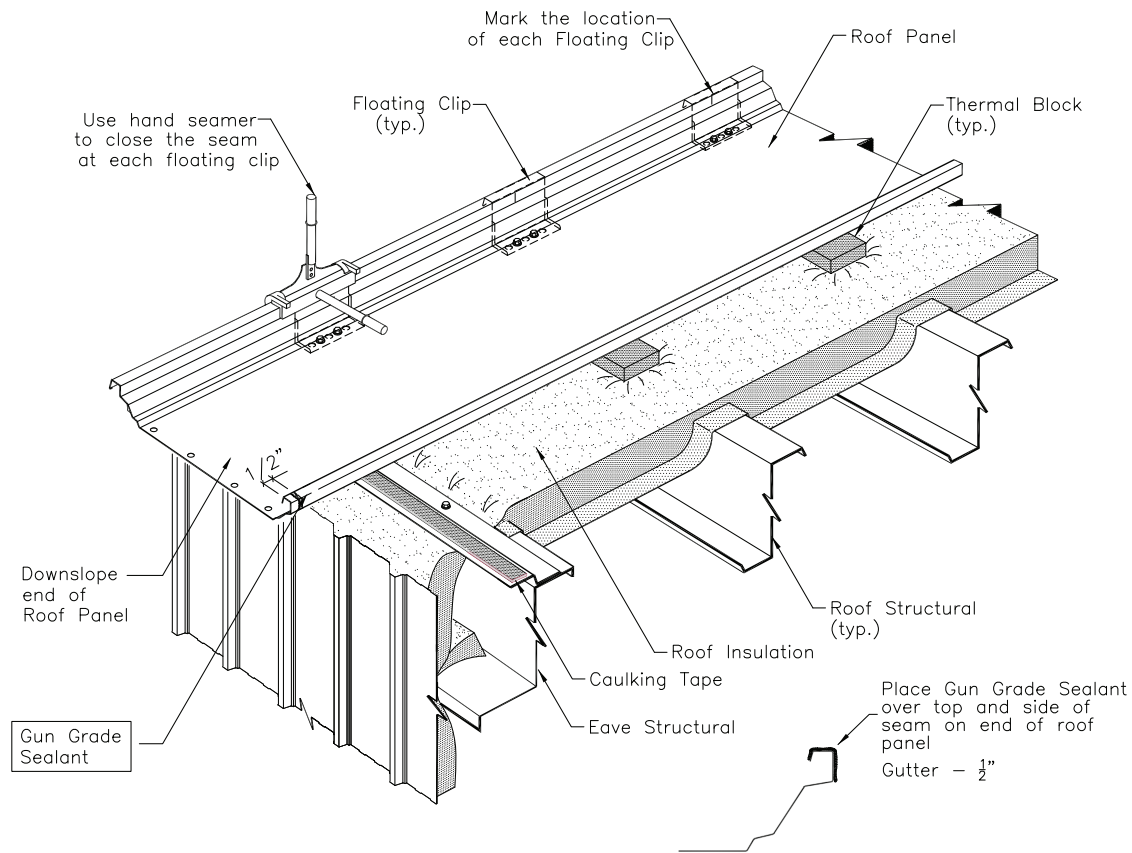

#### 9.3.7 INSTALL EAVE CLOSURE

Prepare the metal void closures by applying caulking tape along the top surfaces and install Closure Clip into closure as shown in the above illustration.

Peel back the protective paper from one side and rotate closure and clip onto prepared rib as shown.

Place the closure 1/2" beyond the leading edge of roof panel.

Check that the closure is centered to the roof panel's edge.

Pull off the other half of the protective paper before installing the next panel.

Keep heated sealants warmer in the winter or cooler in the summer by storing them in plastic coolers while working on the roof.

## 9.0 ROOF INSTALLATION DETAILS

### 9.3 ROOF PANEL INSTALLATION - WITH GUTTER

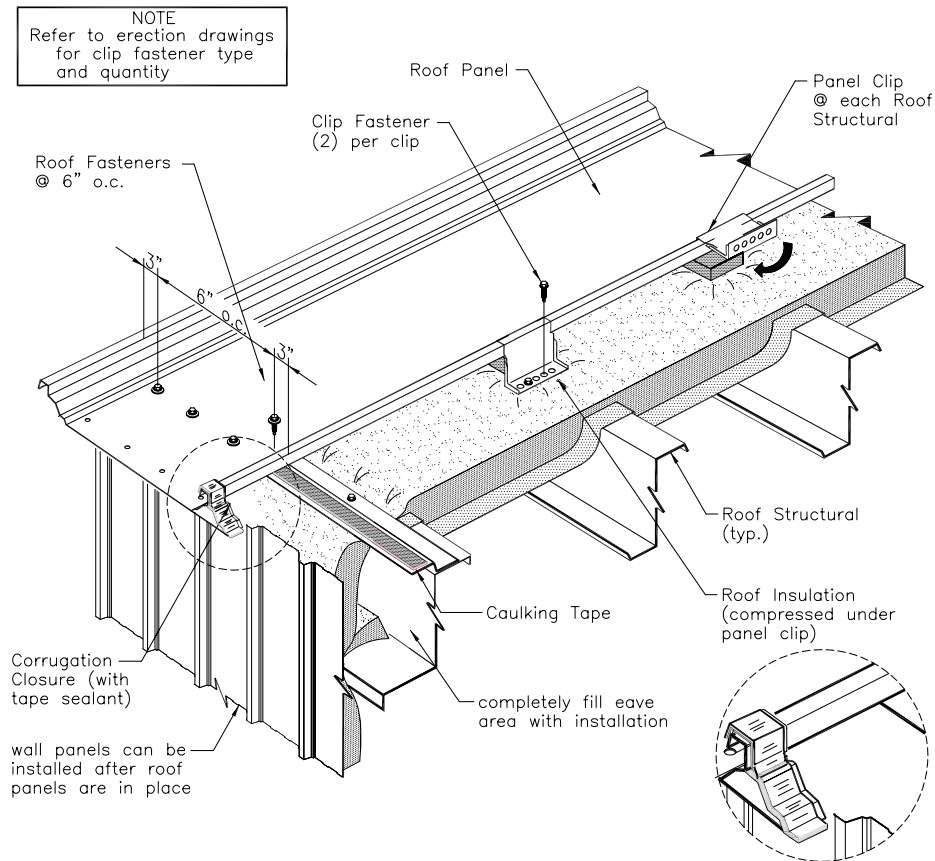

#### 9.3.8 ATTACH ROOF PANEL

Before fastening the roof panel to the eave plate and fastening the leading edge of the panel with the panel clips, check that the panel coverage is correct and the leading edge of the panel is straight and parallel to the gable line.

Fasten the panel with (4) roof fasteners spaced 6" O.C. as shown. Position the fasteners to penetrate into the eave plate.

Prepare tape sealant on Closure Clip as shown in the above detail. See page 9-25 for eave pigtail sealant detail.

Install roof panel clips to the leading edge of the roof panel at each roof structural. Panel clips are not required at the eave structural. Ensure all clips have factory applied sealant.

To install the clips, tilt the clip so that its tab can be hooked over the edge of the roof panel's male seam, then rotate the clip down into the vertical position. Position the clip's base so that the clip fasteners can be installed through the holes in the base and into the roof structural.

When fibreglass roof insulation is used, the panel clips normally sit on top of the insulation and the insulation is compressed between the clip's base and the top of the roof structural. In all cases, refer to the erection drawings to determine the required insulation assembly and the relationship of the panel clips to the insulation.

## 9.0 ROOF INSTALLATION DETAILS

### 9.3 ROOF PANEL INSTALLATION

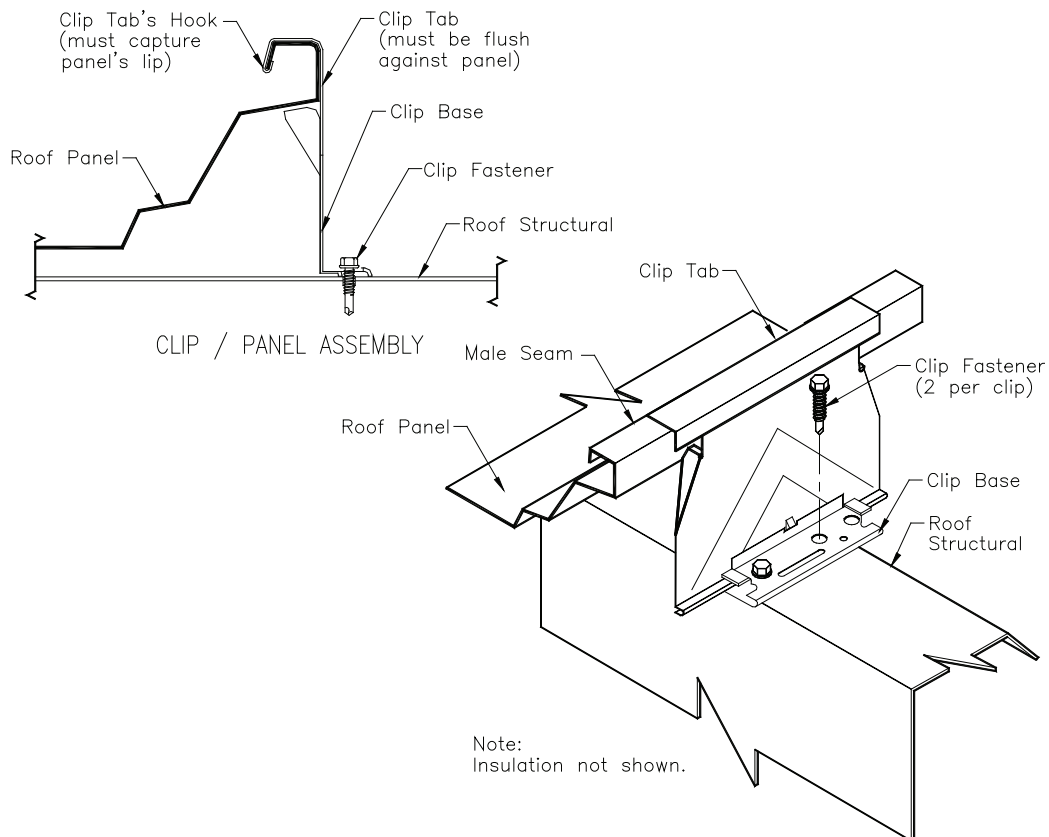

#### 9.3.9 PANEL CLIP DETAILS

Panel clips are available as floating clips and are available in different stand-off heights. Refer to the erection drawings to determine the type of clip required for each roof condition.

Check that the panel clip's tab is seated tightly around the roof panel's seam and that the panel clip's hook has captured the panel's lip.

Check that the clip's base is vertical and that the base is set square and firmly over the roof structural.

Panel clip fastener type and quantity vary according to the roof structural material and roof load requirements. Refer to the erection drawings for the required type and quantity of panel clip fasteners.

Check that the clip fasteners are equally spaced through the clip base holes and are securely engaged into roof structural.

## 9.0 ROOF INSTALLATION DETAILS

### 9.3 ROOF PANEL INSTALLATION

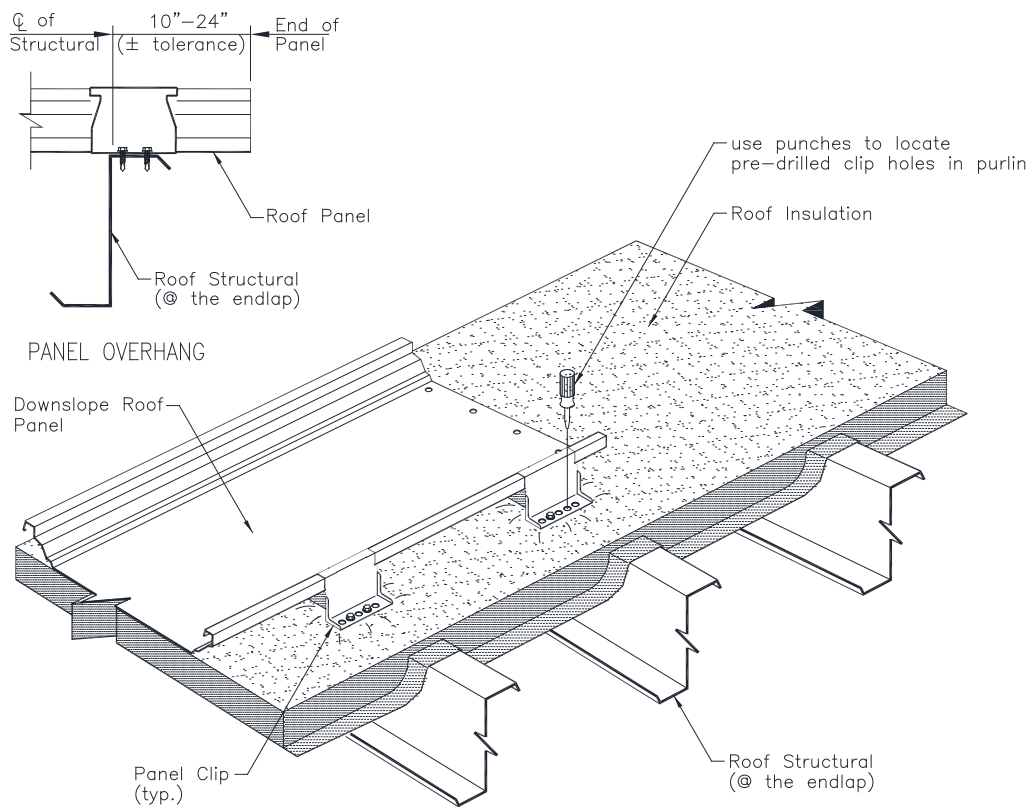

#### 9.3.10 ENDLAP – VERIFY PANEL OVERHANG

With the eave end of the roof panel attached, measure the panel overhang at the purlin (see illustration).

The panel should extend 10" beyond the center line of the purlin or joist.

Refer to the erection drawings for the dimensions.

If the panel overhang is not within this range, contact your Project Manager before proceeding with the installation of roof panels.

## 9.0 ROOF INSTALLATION DETAILS

### 9.3 ROOF PANEL INSTALLATION

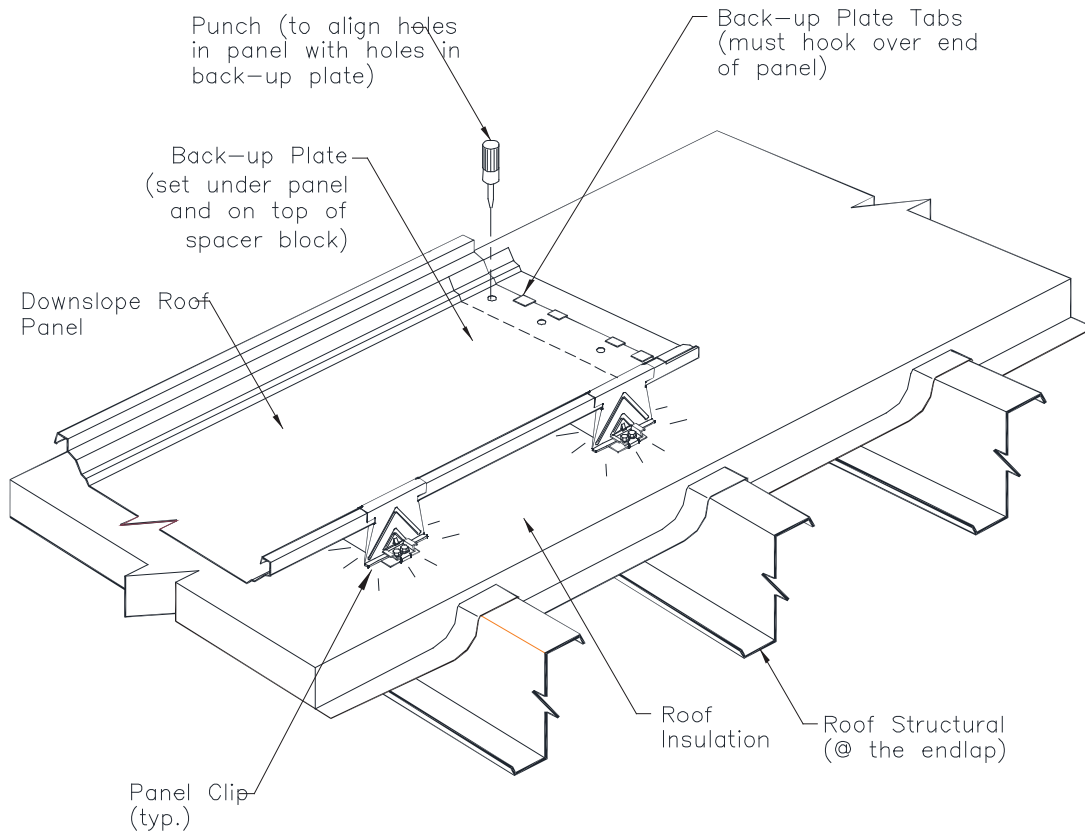

#### 9.3.11 ENDLAP – INSTALL BACK-UP PLATE

Slide the back-up plate under the roof panel, as shown.

The back-up plate must be set over the top of the roof structural. If insulation thermal blocks are used, the back-up plate must be set over the spacer block.

The back-up plate's tabs must hook over the end of the roof panel.

Use punches to align the holes in the back-up plate with the factory punched holes in the roof panel.

## 9.0 ROOF INSTALLATION DETAILS

### 9.3 ROOF PANEL INSTALLATION

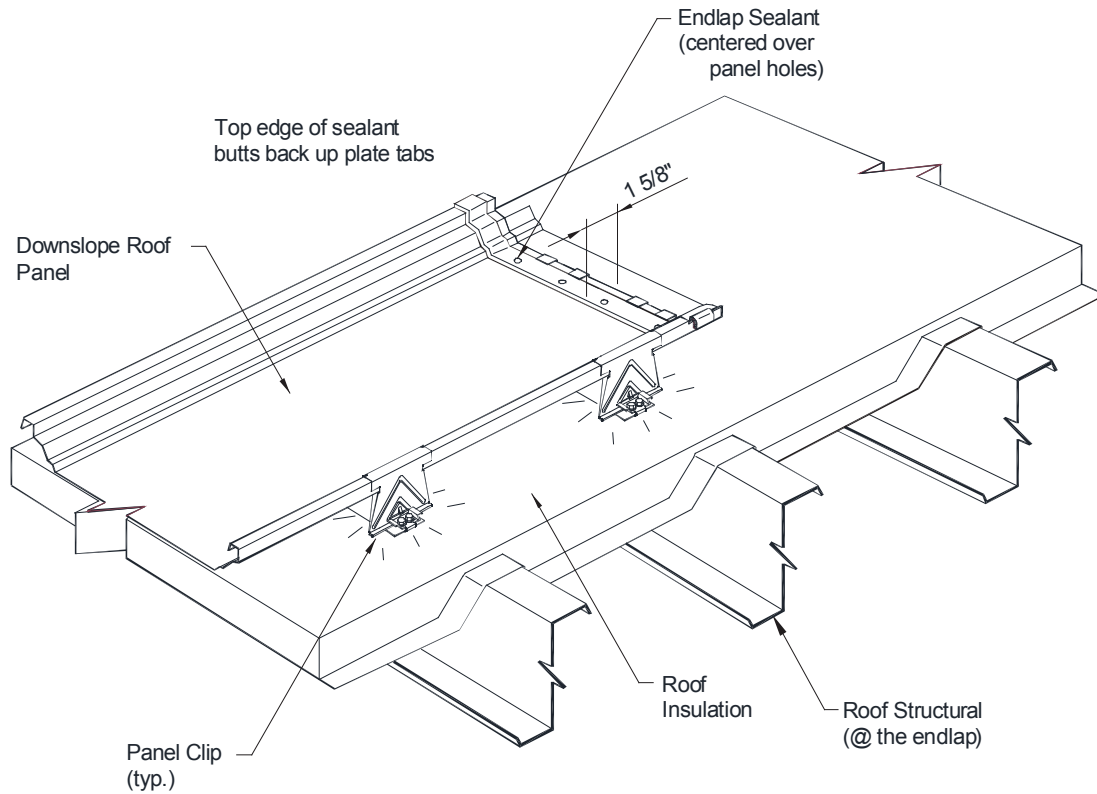

#### 9.3.12 ENDLAP – INSTALL CAULKING TAPE

The proper placing of the caulking tape is critical to the weathertightness of the roof endlaps.

Before installing the caulking tape, the roof panel's surface must be wiped clean and dry.

Position the sealant so that its downslope edge is uniformly 1 5/8" from the end of the panel. The sealant must be centered over the roof panel's factory punched holes.

Install a continuous strip of caulking tape along the top end of the roof panel, as shown. When tape sealant is applied at an inside radius, it is recommended that the sealant be folded back on itself, then push the sealant fold into the radius.

Check that the sealant fully contacts the roof panel's surface and that it is completely fitted into the panel corners and around the seams.

The sealant's protective paper helps to retain the sealant's shape during installation and protects the sealant's surface from damage and contamination. Do not remove the protective paper until immediately before the installation of the up-slope roof panel.

## 9.0 ROOF INSTALLATION DETAILS

### 9.3 ROOF PANEL INSTALLATION

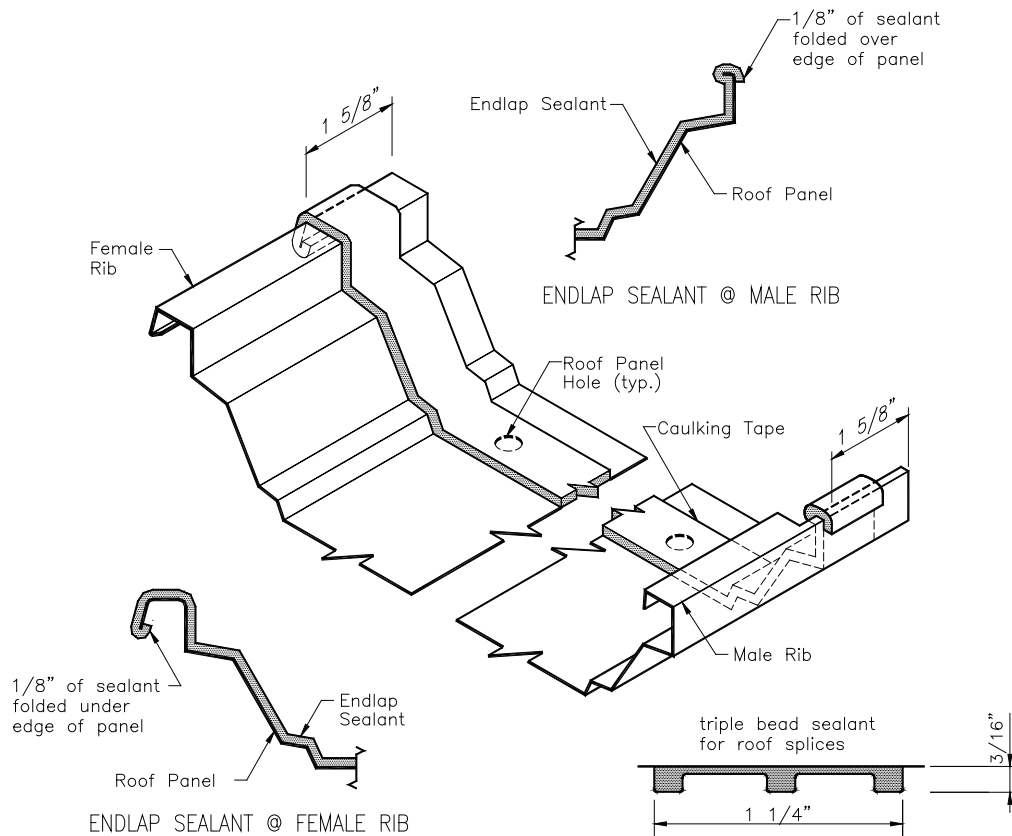

#### 9.3.13 ENDLAP – CAULKING DETAILS

Cut the caulking tape to be fitted around the roof panel's seams as shown.

Check that the  $\frac{1}{8}$ " ends of the caulking are correctly folded around the roof panel's edges. Excess sealant in the roof panel seams will cause difficult panel assembly. Remove any excess sealant.

After the caulking is correctly positioned, uniformly press the sealant against the roof panel's surface to assure adhesion. Do not use excess pressure which can thin the caulking.

Keep heated sealants warmer in the winter and cooler in the summer by storing them in a plastic cooler while working on the roof.

## 9.0 ROOF INSTALLATION DETAILS

### 9.3 ROOF PANEL INSTALLATION

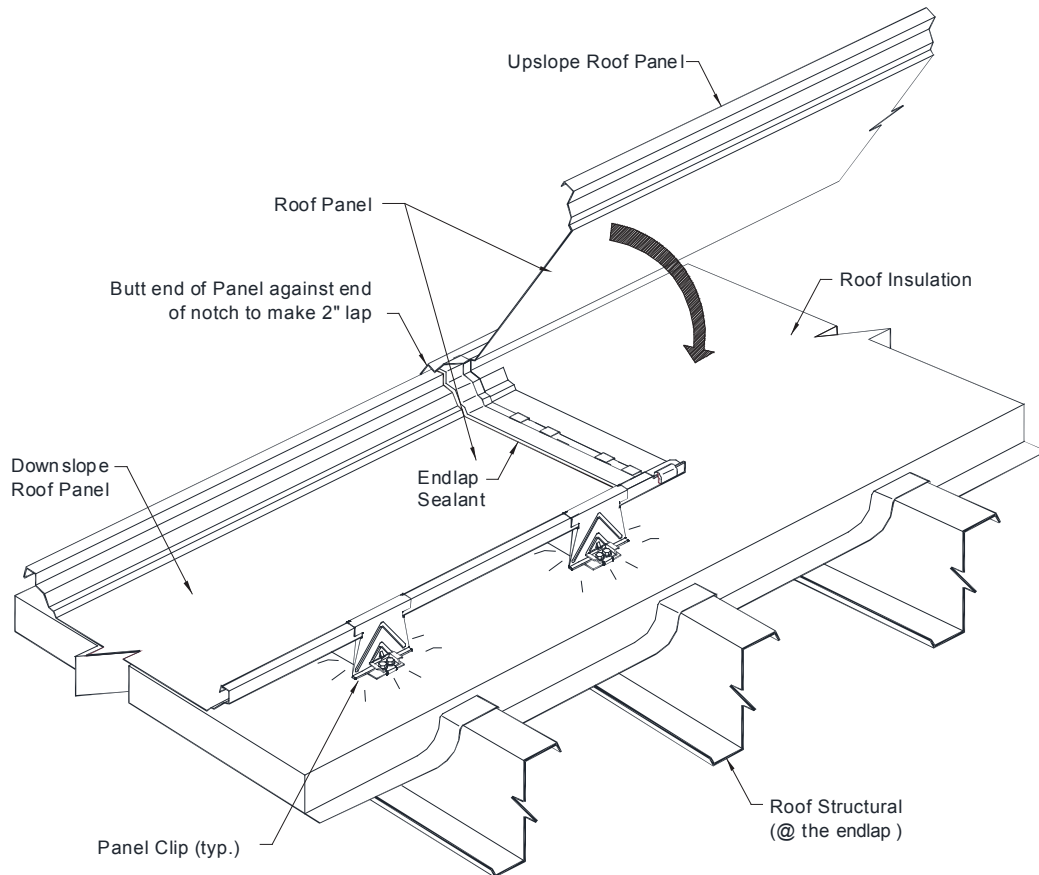

#### 9.3.14 ENDLAP – UP-SLOPE PANEL PLACEMENT

Wipe dry and clean the underside surface of the up-slope roof panel.

Remove the protective paper from the installed caulking tape.

Position the end of the up-slope roof panel to make a 2" lap over the down-slope roof panel.

At the seams, the end of the up-slope roof panel should butt against the notch on the down-slope roof panel.

Check that the up-slope roof panel will correctly lap over the caulking tape.

## 9.0 ROOF INSTALLATION DETAILS

### 9.3 ROOF PANEL INSTALLATION

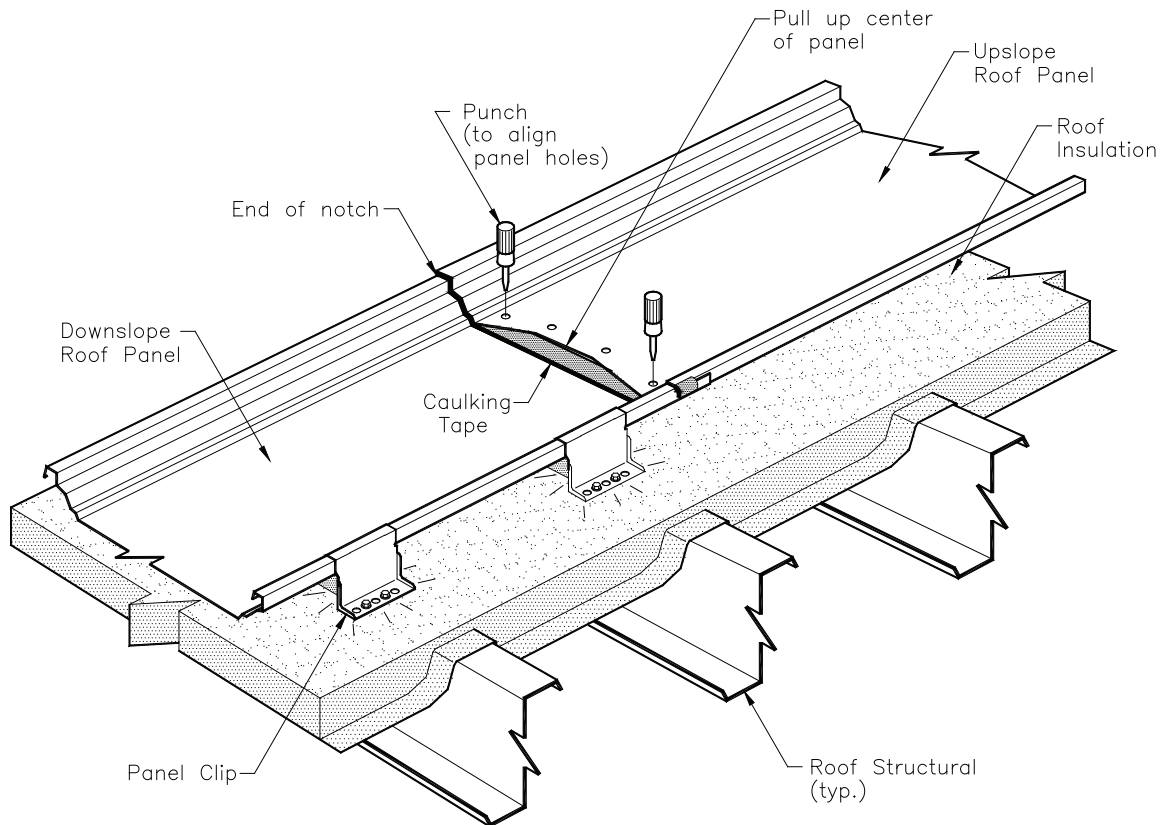

#### 9.3.15 ENDLAP – PANEL ALIGNMENT

Lower the up-slope roof panel to lap onto the down-slope roof panel.

While lowering the up-slope roof panel, bow the end of the panel by pulling up on its center. This will allow the panel to more readily nest into the down-slope panel.

Use punches to align the factory punched holes of the lapping panels. The punch will have to penetrate through the caulking tape and into the holes in the back-up plate. Do not disturb the position of the caulking while inserting and removing the punch.

Do not remove the punches from the roof panel holes until after the seam clamps have been installed.

## 9.0 ROOF INSTALLATION DETAILS

### 9.3 ROOF PANEL INSTALLATION

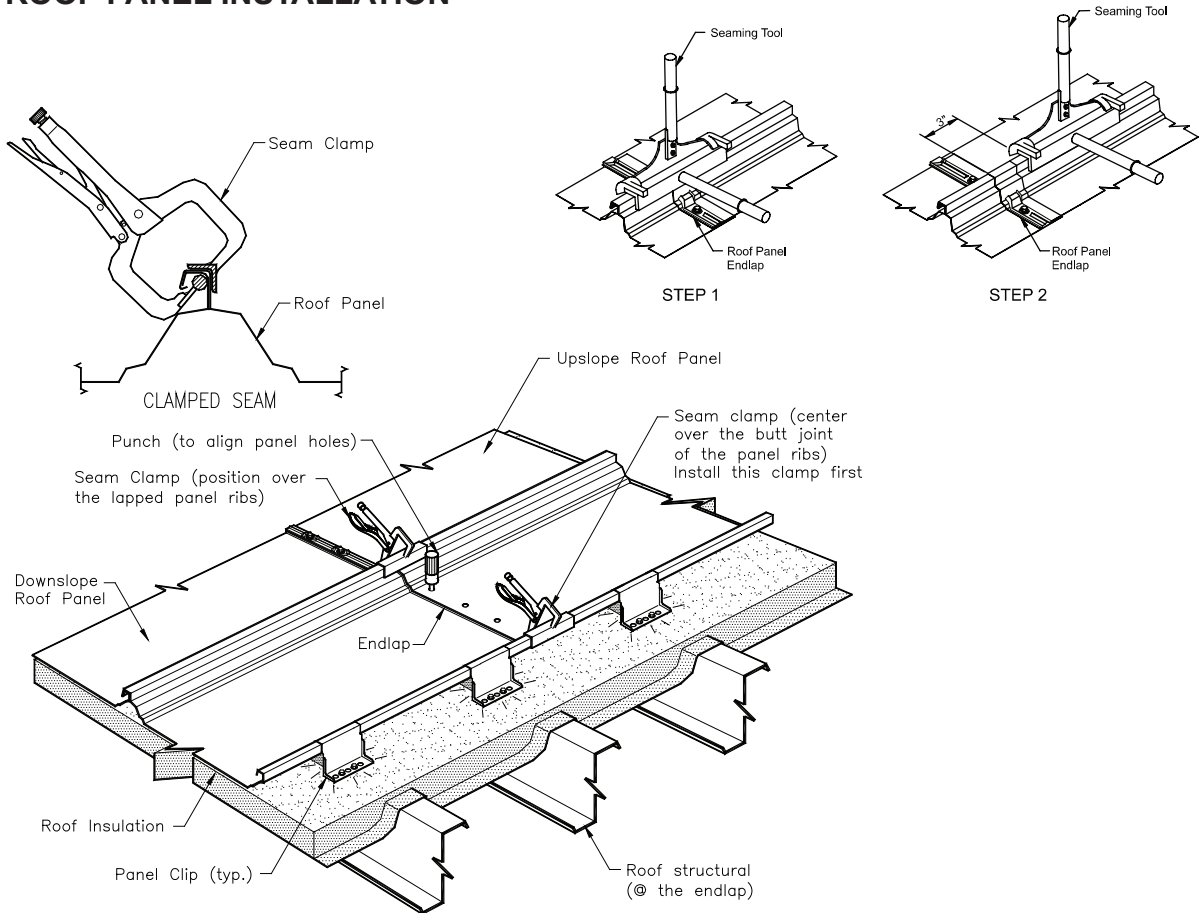

#### 9.3.16 ENDLAP – CLAMP THE SEAMS

Use the seam clamps to draw the lapping panel seams together, as shown. Install leading edge seam clamp first.

Check that the clamp jaws are correctly aligned to the seam before closing the clamp. Misaligned clamps can distort and damage the roof panel seams.

Slowly close the clamp to allow the sealant to flow between the lapped seams.

With the seam clamps installed, uniformly press down on the up-slope panel to close the panel lap and to assure adhesion to the caulking tape.

Do not remove the seam clamps until after the endlap cinch strap has been installed.

## 9.0 ROOF INSTALLATION DETAILS

### 9.3 ROOF PANEL INSTALLATION

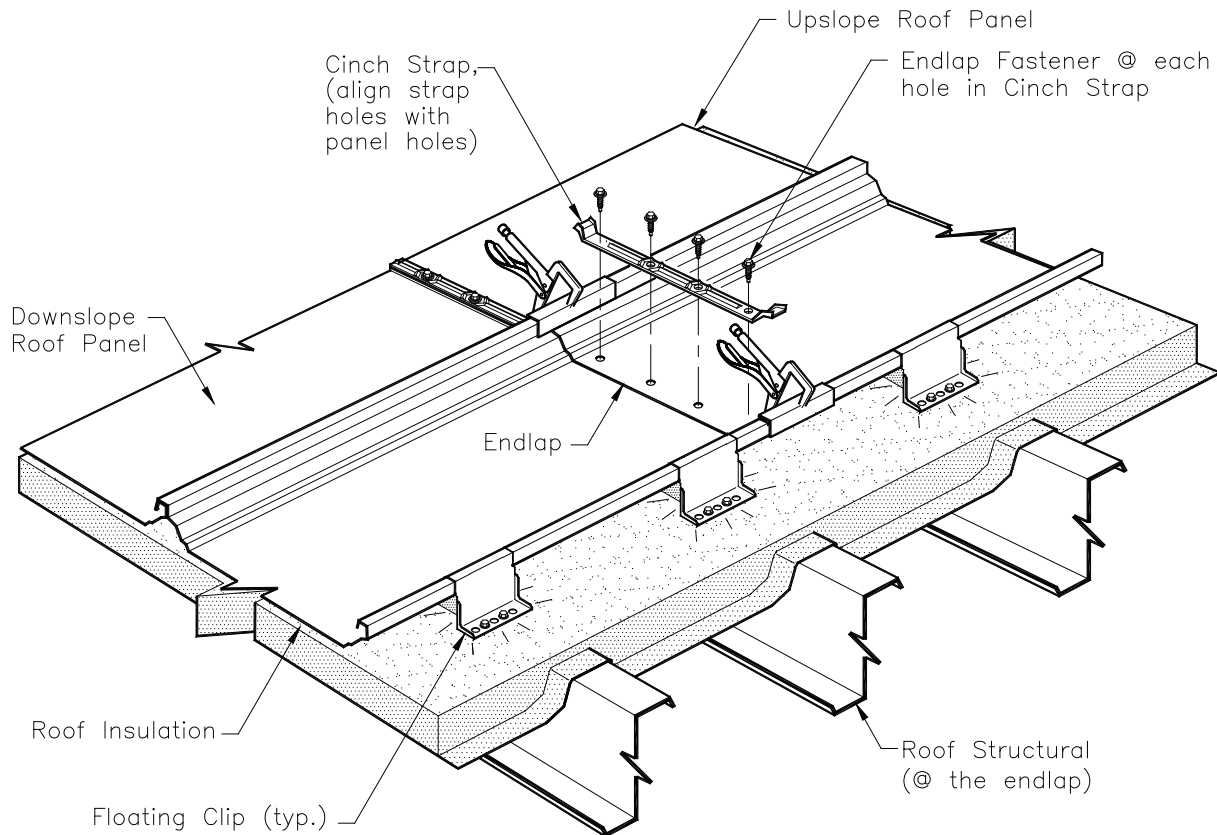

#### 9.3.17 ENDLAP – INSTALL CINCH STRAP

Carefully remove the punches and position the cinch strap over the factory punched holes in the roof panel.

Use a punch to align the factory punched holes in the cinch strap, roof panels and back-up plate.

Install endlap fasteners in the holes at each end of the cinch strap. Next install fasteners in the remaining holes.

Check that the endlap fasteners penetrate thru the center of the endlap sealant and are securely engaged into the back-up plate.

Specific endlap details are shown on the following page.

## 9.0 ROOF INSTALLATION DETAILS

### 9.3 ROOF PANEL INSTALLATION

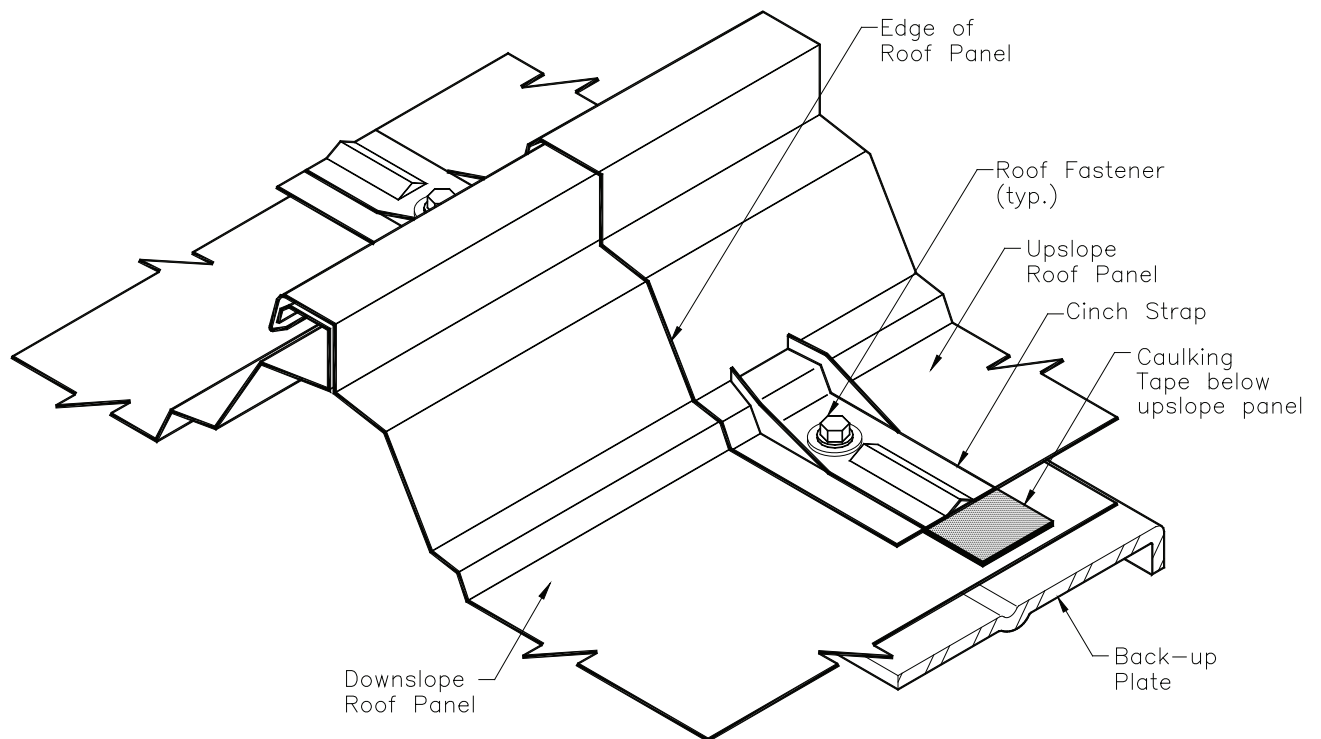

#### 9.3.18 ENDLAP – ASSEMBLY DETAIL

Check that the endlap is correctly assembled, as shown.

Check that there are no unsealed voids between the lapped panels, especially at the critical corner areas.

## 9.0 ROOF INSTALLATION DETAILS

### 9.3 ROOF PANEL INSTALLATION

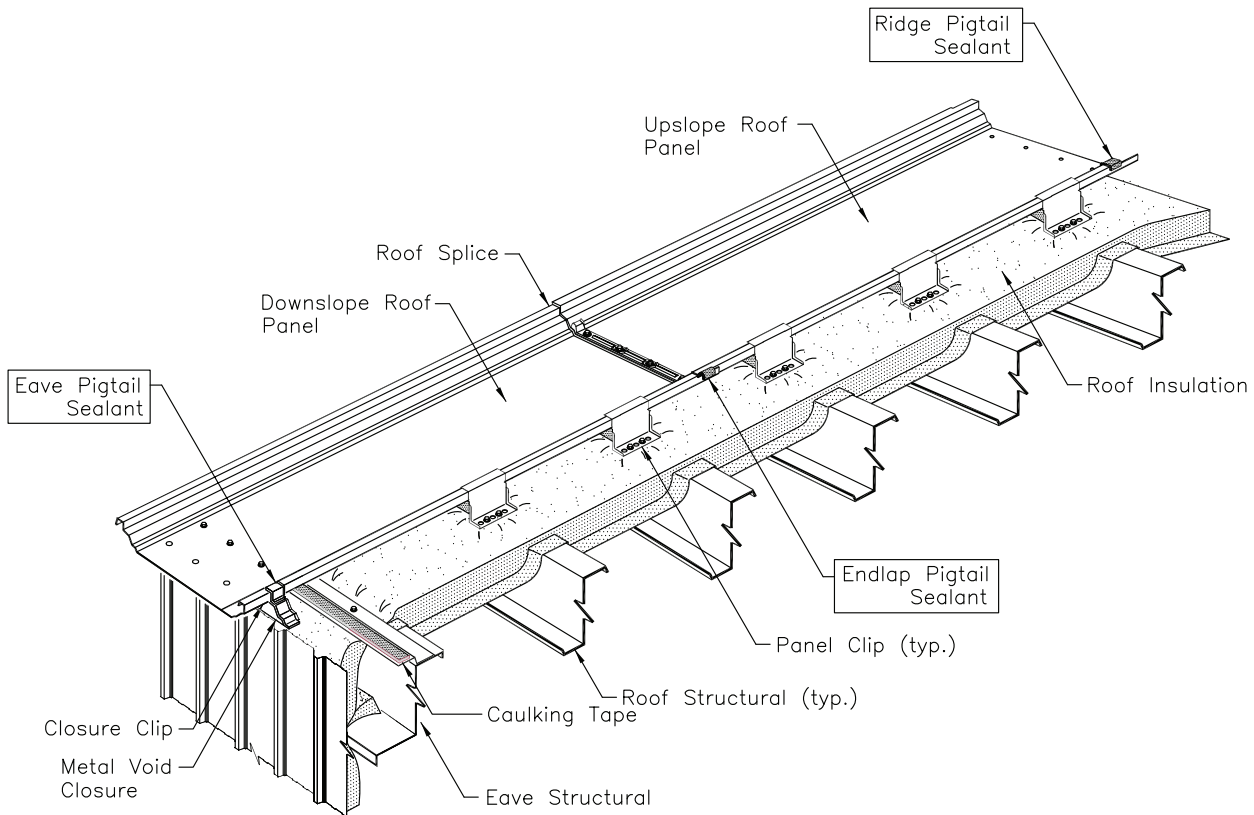

#### 9.3.19 INSTALL PIGTAIL SEALANTS

The pigtail sealants must be correctly installed before the next roof panel run can be installed.

Install the eave, endlap and ridge pigtail sealants on the leading edge of the roof panel as shown.

The pigtail sealants are pieces of endlap sealant cut to the required length.

Refer to the next pages for specific pigtail sealant details.

It is critical that all pigtail sealants be installed correctly for a water tight seal.

## 9.0 ROOF INSTALLATION DETAILS

### 9.3 ROOF PANEL INSTALLATION

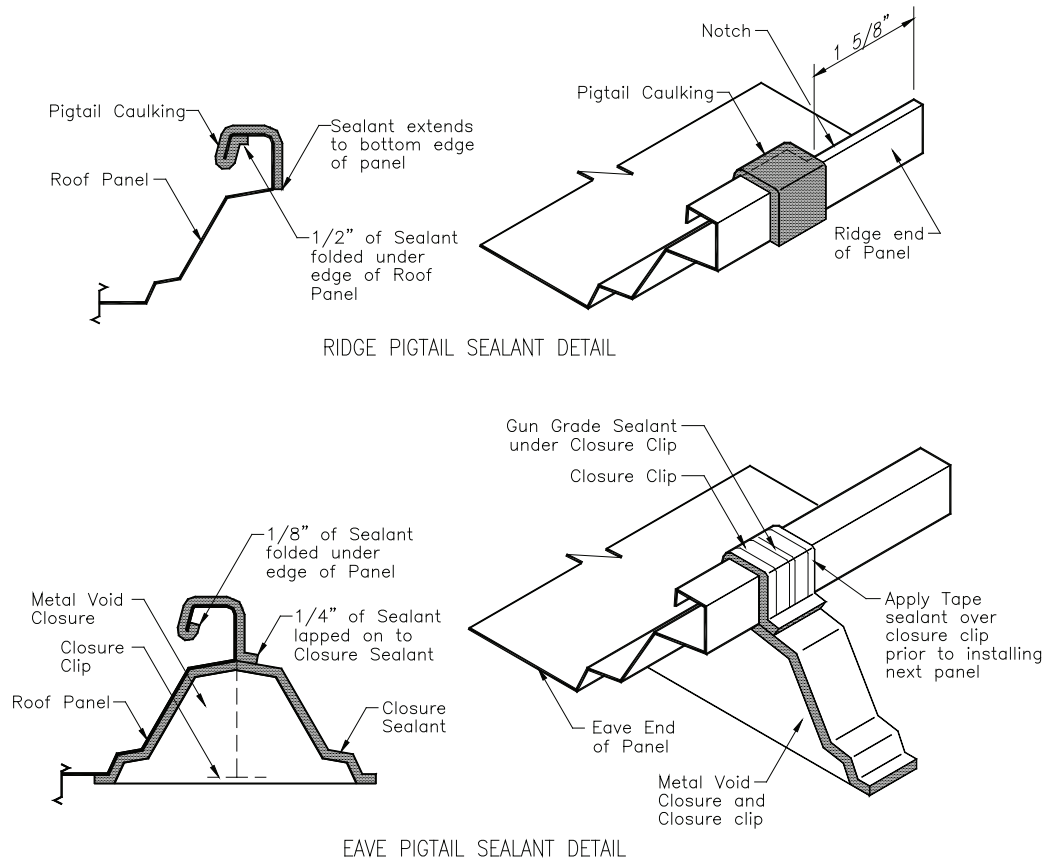

#### 9.3.20 PIGTAIL SEALANT DETAILS AT EAVE & RIDGE

Cut the pigtail sealants to be fitted around the roof panel's seam as shown.

At the eave, lap 1/4" of the pigtail sealant onto the metal void closure's sealant. Cut the other end of the pigtail sealant so 1/8" can be folded under the edge of the roof panel.

At the ridge, position the pigtail sealant so its edge is 1 5/8" from the end of the roof panel. The sealant must lap over the edge of the roof panel's notch.

Fold 1/2" of the ridge pigtail sealant under the edge of the roof panel. Cut the other end of the sealant so it sets flush with the bottom edge of the roof panel's seam.

Excess sealant in the seams will cause difficult roof panel assembly. Remove any excess sealant.

After the pigtail sealant is correctly placed, uniformly press the sealant against the panel's surface to assure adhesion.

## 9.0 ROOF INSTALLATION DETAILS

### 9.3 ROOF PANEL INSTALLATION

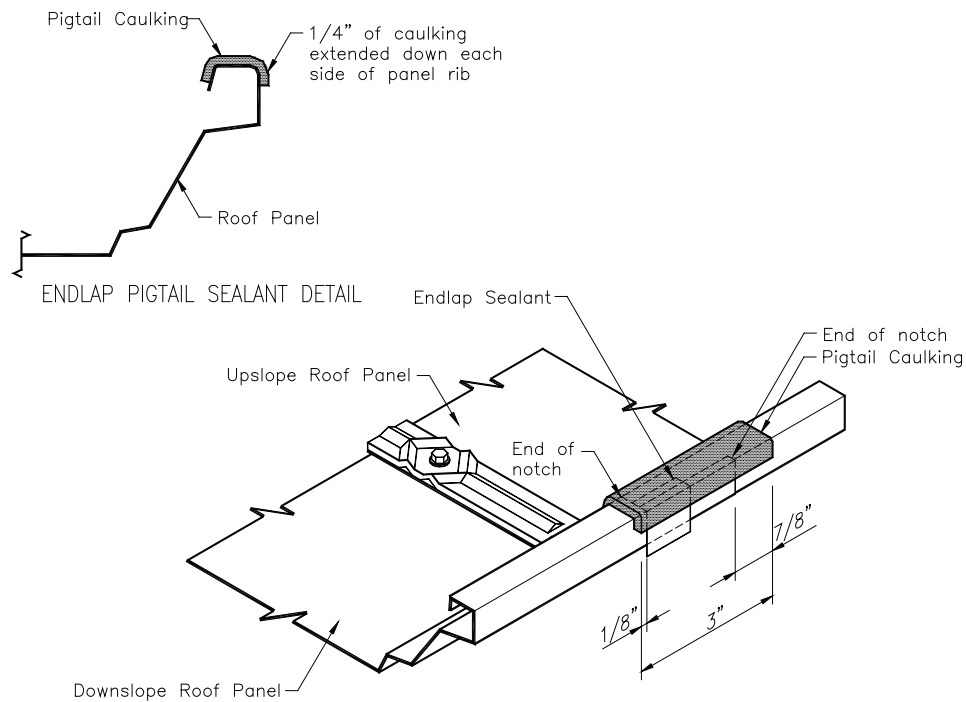

#### 9.3.21 PIGTAIL SEALANT DETAIL AT ENDLAP

Cut the pigtail sealant to a 3" length and fit around the roof panel's seam as shown.

Position the pigtail sealant to lap 1/8" over the downslope end of the roof panel's notch.

Center the sealant over the roof panel's seam. Fold the edges of the sealant down over the sides of the seam.

Excess sealant in the seams will cause difficult roof panel assembly. Remove any excess sealant.

After the pigtail sealant is correctly placed, uniformly press the sealant against the panel's surface to assure adhesion.

## 9.0 ROOF INSTALLATION DETAILS

### 9.3 ROOF PANEL INSTALLATION

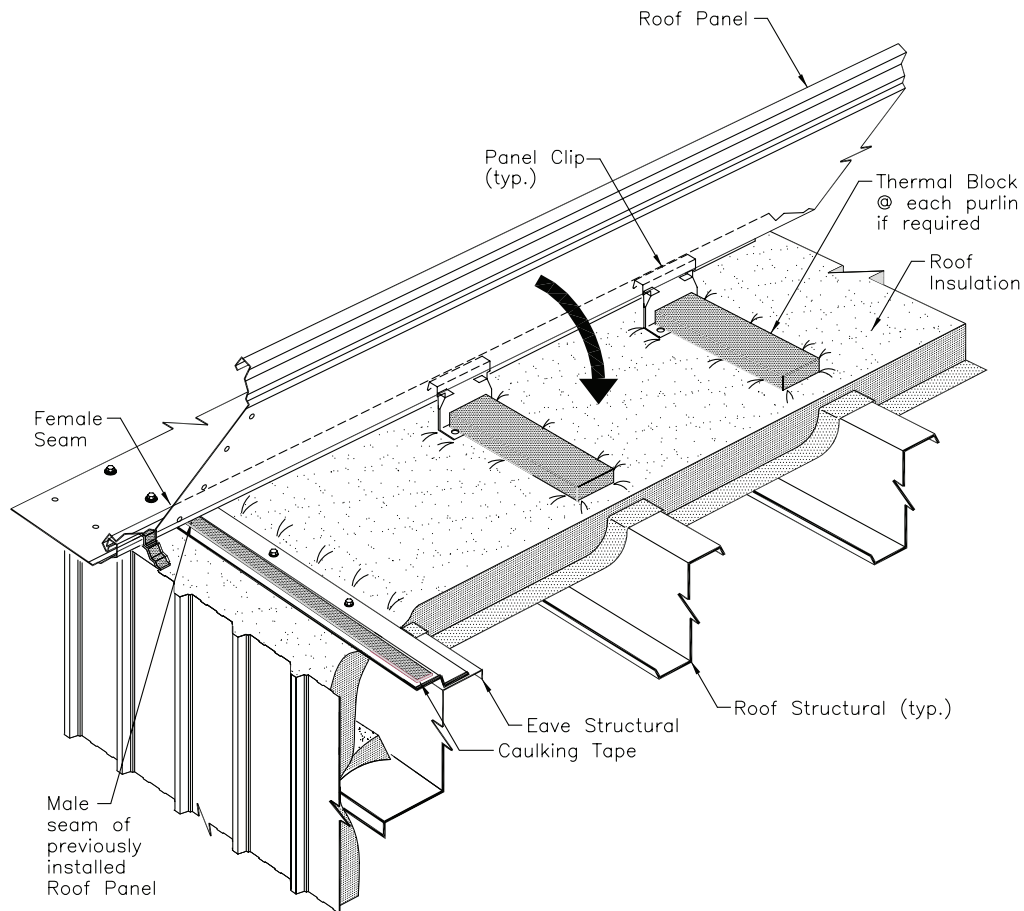

#### 9.3.22 INSTALL INTERMEDIATE PANELS

Remove the protective paper from the closure caulking tape

If required, place the insulation thermal blocks on top of the insulation directly over the roof structural.

Position the trailing edge of the roof panel over the leading edge of the previously installed roof panel and position the end of the roof panel beyond the girt line as shown on the erection drawing.

Tilt the panel as shown so the female seam can be hooked over the male seam of the previous roof panel. Using the hand seaming tool, close the panel seam over each floating clip.

Specific roof panel sidelap assembly details are shown on the following page.

## 9.0 ROOF INSTALLATION DETAILS

### 9.3 ROOF PANEL INSTALLATION

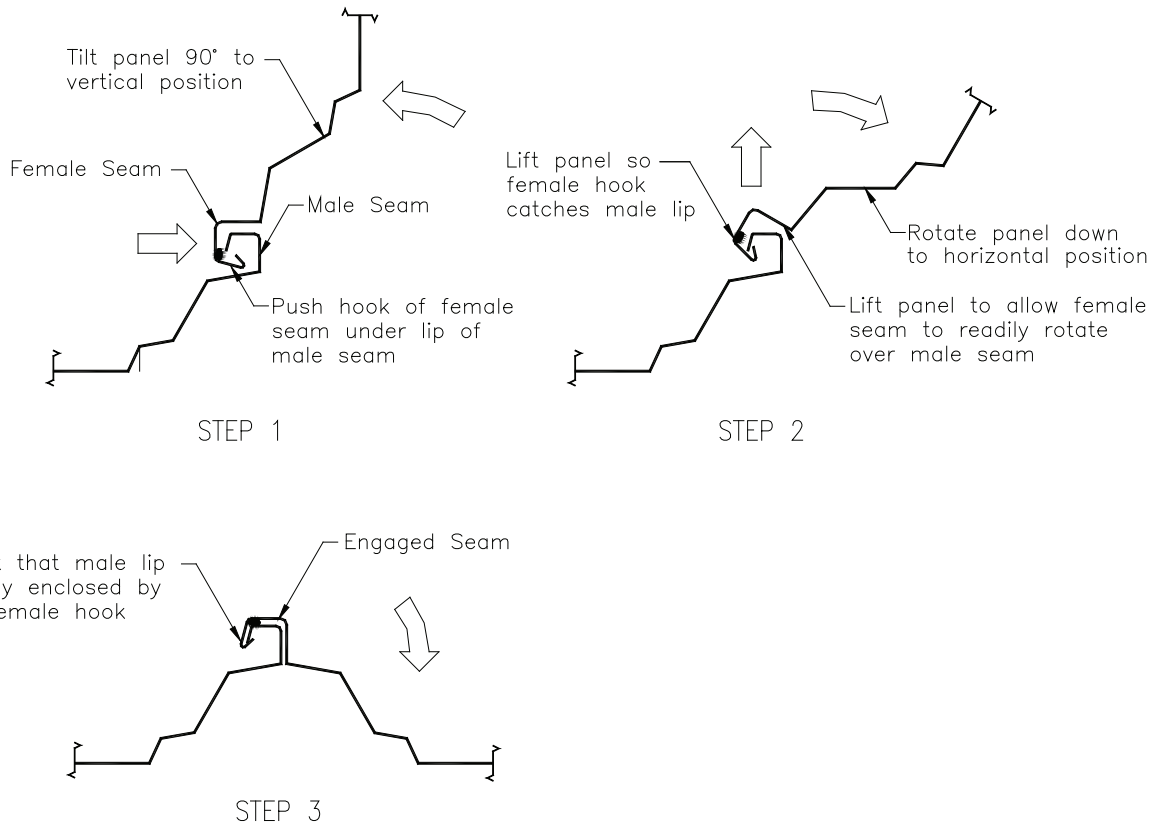

#### 9.3.23 PANEL SIDELAP ASSEMBLY

It is easier to hook the roof panel seams together if the roof panel is first tilted up to the vertical position.

With the roof panel in the vertical position, align its female seam to slide under the male seam of the previous roof panel.

With the female seam under the male seam, lift up the roof panel so the female seam's hook catches the lip of the male seam.

While continuing to lift up on the roof panel, rotate the panel down to rest on the insulation or spacer blocks.

Be careful not to scrape off the seam sealant during the sidelap assembly.

#### IMPORTANT

Check that the male and female are fully nested and the female hook has enclosed the male lip along the entire length of the roof panel. If not, the roof panel sidelap must be correctly reassembled before installing the next roof panel.

## 9.0 ROOF INSTALLATION DETAILS

### 9.3 ROOF PANEL INSTALLATION

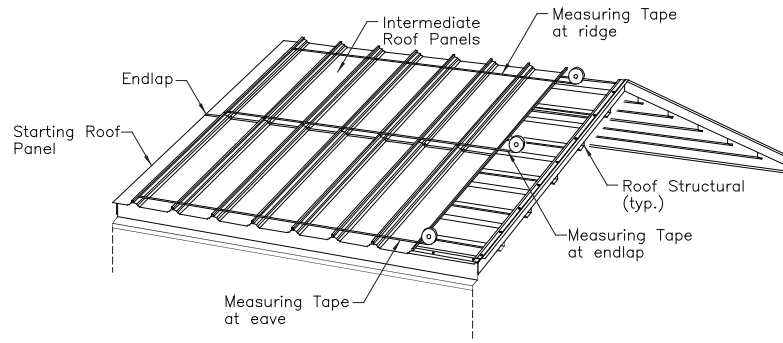

CHECKING PANEL COVERAGE

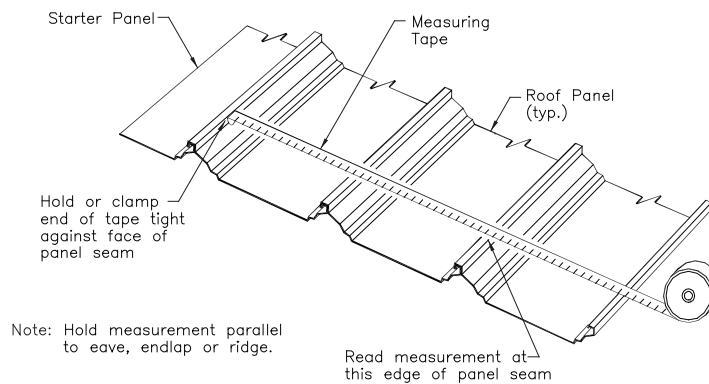

PANEL COVERAGE MEASUREMENT

#### 9.3.24 CHECK PANEL COVERAGE

##### CAUTION

To assure proper fit-up of the sidelap assembly, proper seaming, proper fit-up of closures, flashing, curbs, etc., it is important that each panel be held to within the 1/8" panel coverage tolerance and that overall coverage be checked frequently and any coverage error be corrected before it accumulates.

Coverage must be checked at the eave and ridge and at every endlap (splice).

To avoid accumulation error, the coverage measurement should always be from the gable line or the starting roof panel's seam.

To avoid measurement error, the measuring tape must be free and taut and must be parallel to the eave line or ridge line.

## 9.0 ROOF INSTALLATION DETAILS

### 9.3 ROOF PANEL INSTALLATION

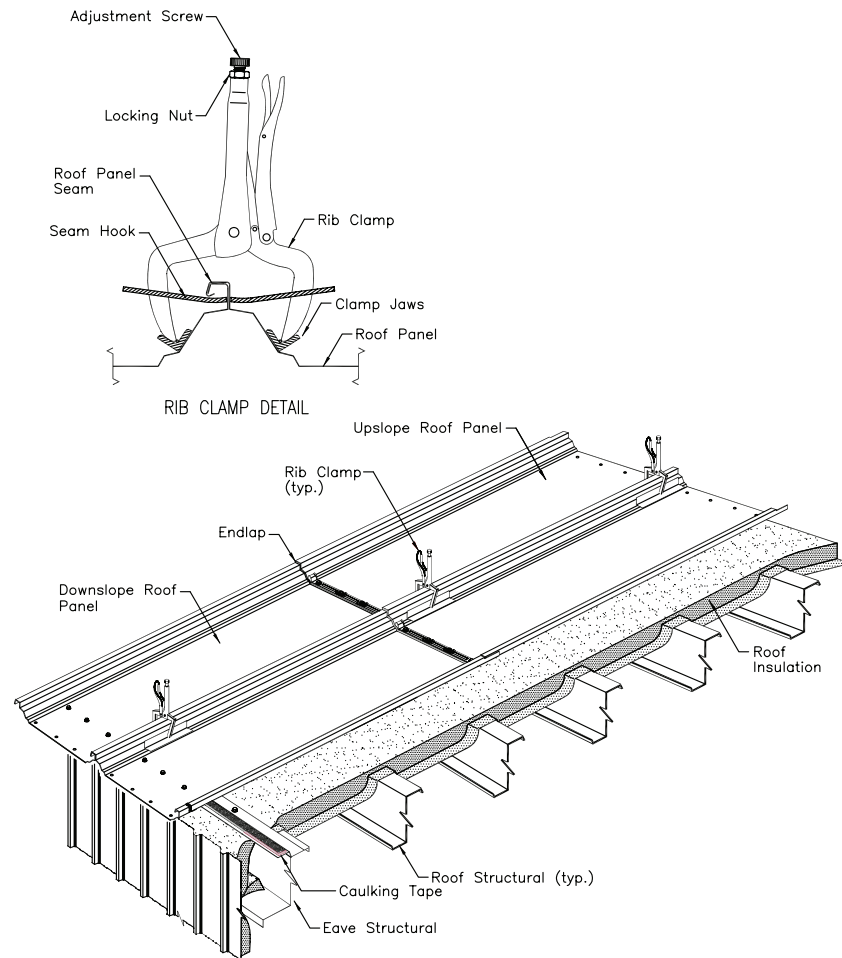

#### 9.3.25 ADJUST PANEL COVERAGE

The most common coverage error is the spreading of the roof panels, especially at the panel ends. This can cause excess panel coverage along the eave, endlaps and ridge.

To correct excess roof panel coverage, use rib clamps to squeeze together the panel ribs as shown.

The rib clamps can be adjusted and locked so that they will squeeze the panel ribs to provide a consistent coverage width.

If excessive coverage has accumulated over several panel runs, do not try to correct all of the error at one time. Corrected roof panel coverage must not be greater than 1/8" per panel. Correct accumulated coverage error by making the correction over several panel runs.

## 9.0 ROOF INSTALLATION DETAILS

### 9.4 PREPARATION FOR TERMINATION PANEL INSTALLATION

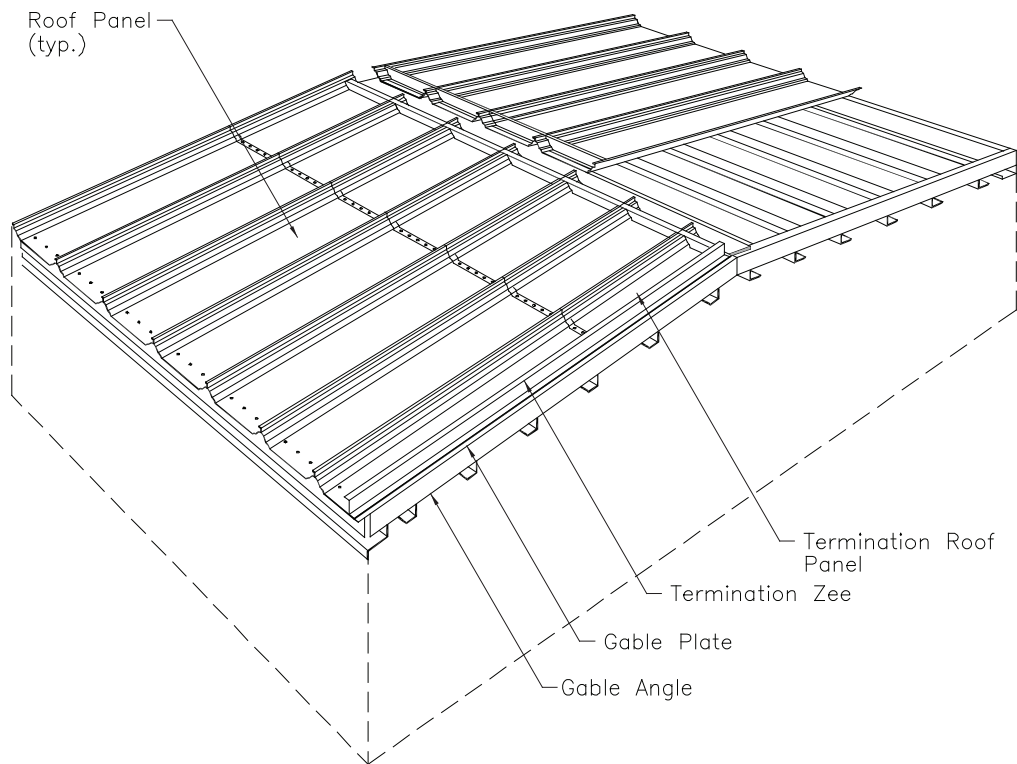

#### 9.4.1 ORIENTATION VIEW

The details in this section show the installation of gable plate, termination roof panel and the termination zee.

The details show the termination roof panel installed at the finish gable. The installation of the termination panel at the starting gable (when required) is similar. See erection drawings for start and termination ends.

## 9.0 ROOF INSTALLATION DETAILS

### 9.4 PREPARATION FOR TERMINATION PANEL INSTALLATION

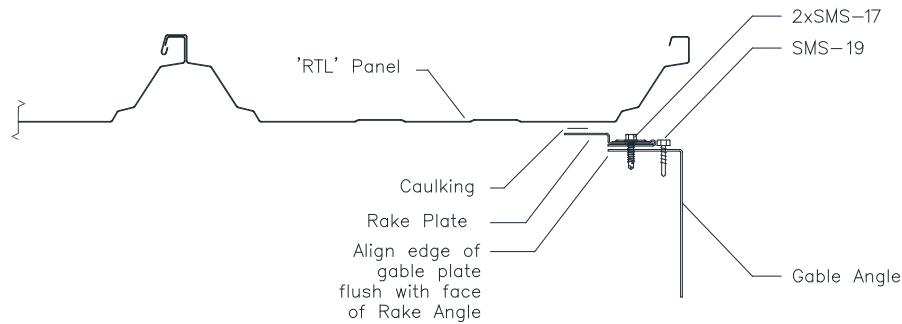

STANDARD GABLE PLATE POSITION

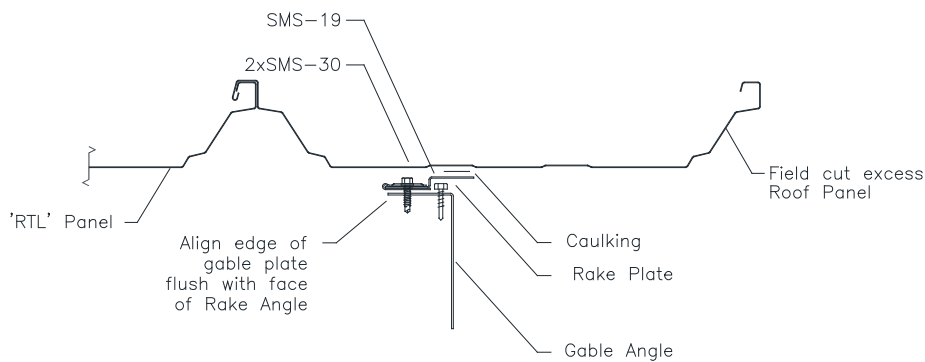

ALTERNATE GABLE PLATE POSITION

#### 9.4.2 GABLE PLATE POSITION FOR GABLE TRIM

Refer to the erection drawings to determine which position to place the gable plate. The position of the gable plate will depend on the location of the termination roof panel as shown on the above illustrations.

If the floating clip interferes with the placement of the gable plate then install the alternate gable plate position. Refer to the erection drawings for correct placement.

If the gable condition requires transition flashing, refer to the following page.

## 9.0 ROOF INSTALLATION DETAILS

### 9.4 PREPARATION FOR TERMINATION PANEL INSTALLATION

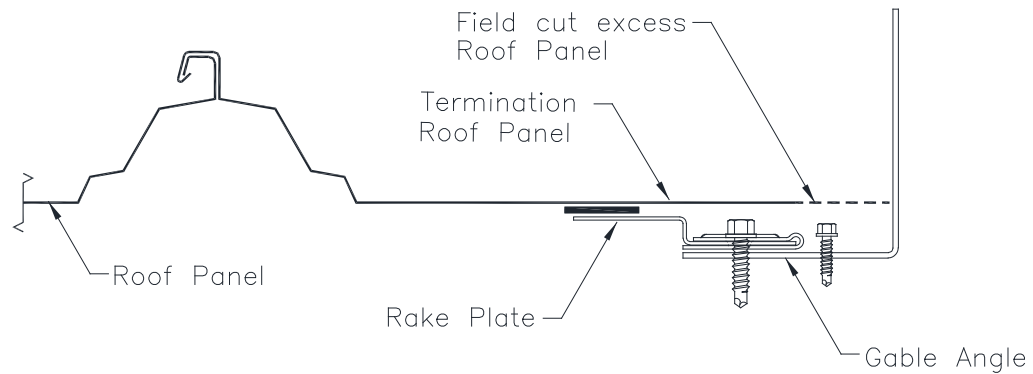

GABLE PLATE POSITION AT TRANSITION

#### 9.4.3 GABLE PLATE POSITION FOR GABLE TRANSITION

For gable transition conditions, position gable plate as shown.

Refer to the erection drawings for the required spacing of the gable plate from the face of the gable angle.

## 9.0 ROOF INSTALLATION DETAILS

### 9.4 PREPARATION FOR TERMINATION PANEL INSTALLATION

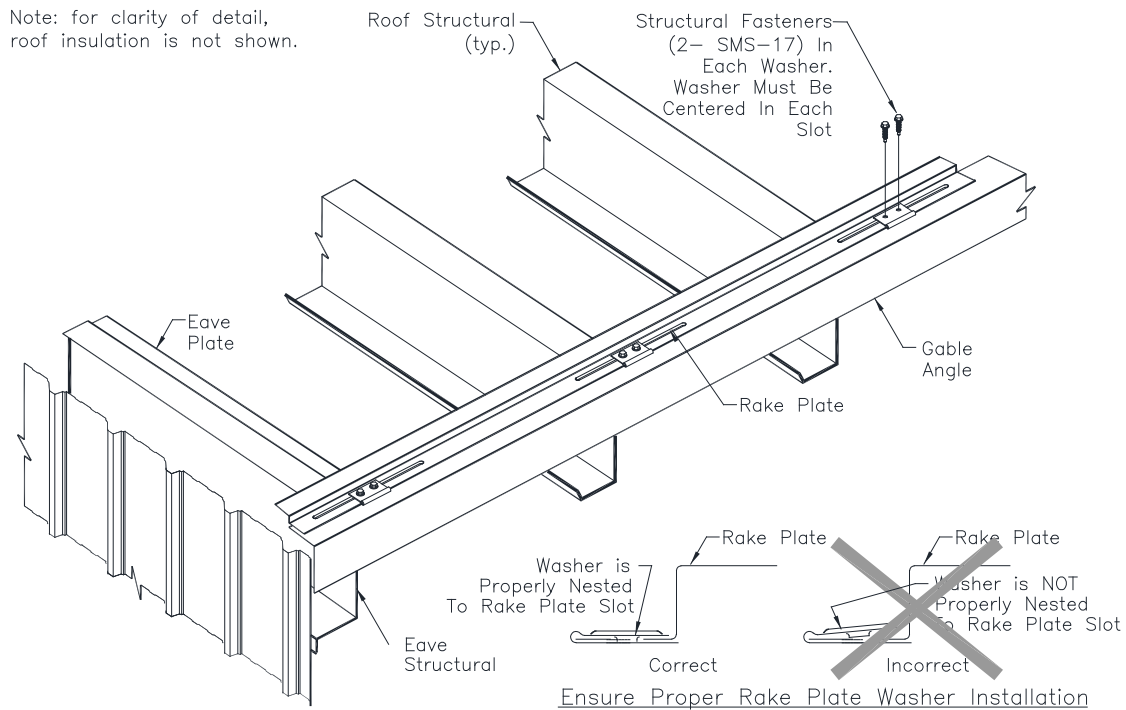

#### 9.4.4 START GABLE PLATE INSTALLATION AT EAVE

It is important that the gable plate is installed in a straight line and parallel to the gable line.

If the gable angles have been installed straight and true, the edge of the gable angle can be used to align the gable plate.

If the gable angle is not true and square, a chalkline should be used to guide the installation of the gable plate.

Start the end of the gable plate flush with the outer edge of the gable angle.

Secure the starting end of the gable plate to the gable angle with 2 structural screws in the gable plate's attachment washer.

This allows for expansion/contraction movement.

The gable plate is installed over top of the roof vapour barrier and not on top of the insulation.

## 9.0 ROOF INSTALLATION DETAILS

### 9.4 PREPARATION FOR TERMINATION PANEL INSTALLATION

Note: for clarity of detail,  
roof insulation is not shown.

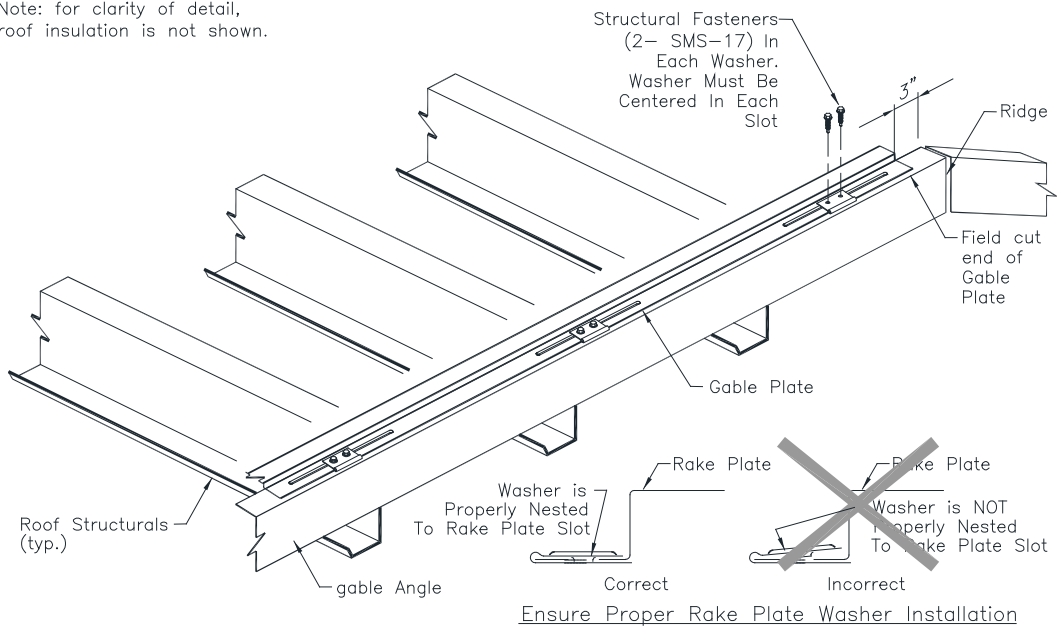

#### 9.4.5 GABLE PLATE ASSEMBLY AT JOINTS & RIDGE

Butt join the ends of the gable plate and angle. Install shoulder screws at each end.

Field cut the last gable plate two inches (3") from the ridge line or high eave line.

## 9.0 ROOF INSTALLATION DETAILS

### 9.5 TERMINATION PANEL INSTALLATION

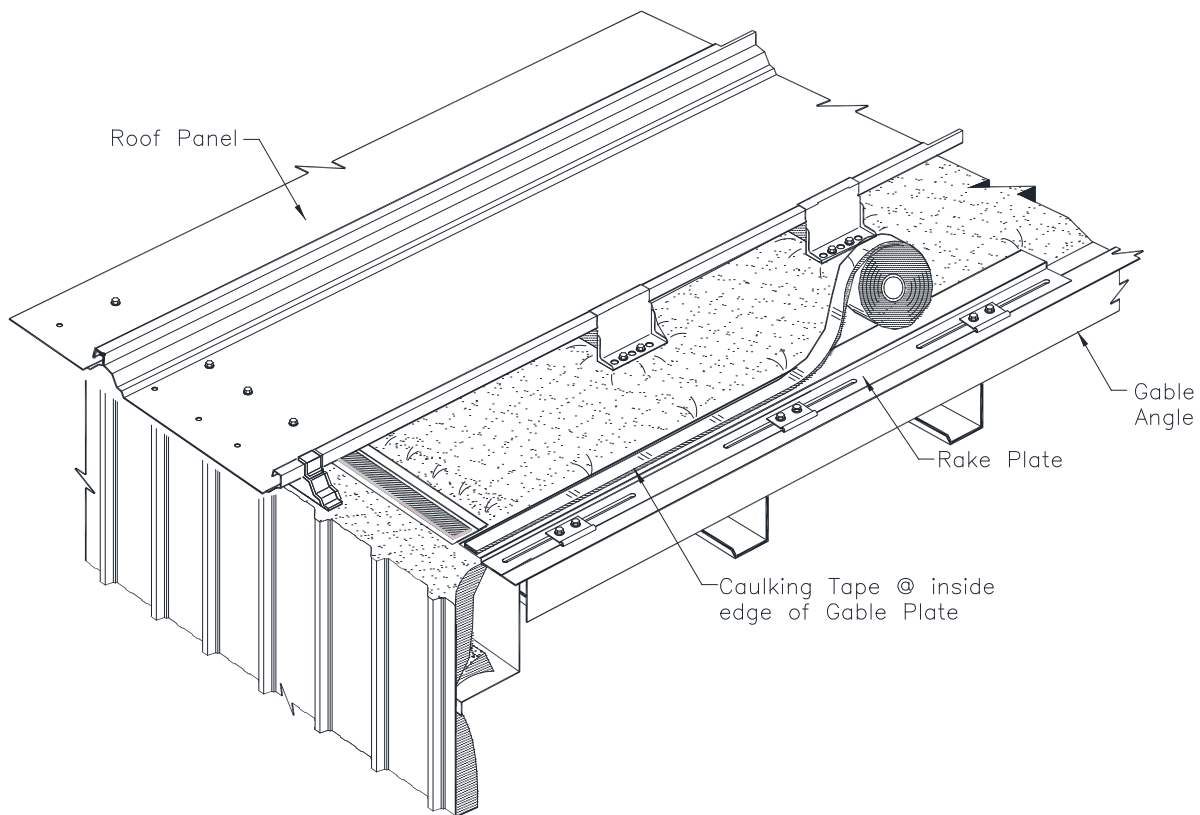

#### 9.5.1 INSTALL GABLE PLATE SEALANT

Install end lap sealant along the top flange of the gable plate as shown.

Position the edge of the caulking tape flush with the inside edge of the gable plate bend.

Do not remove the protection paper until immediately before installing the termination roof panel.

## 9.0 ROOF INSTALLATION DETAILS

### 9.5 TERMINATION PANEL INSTALLATION

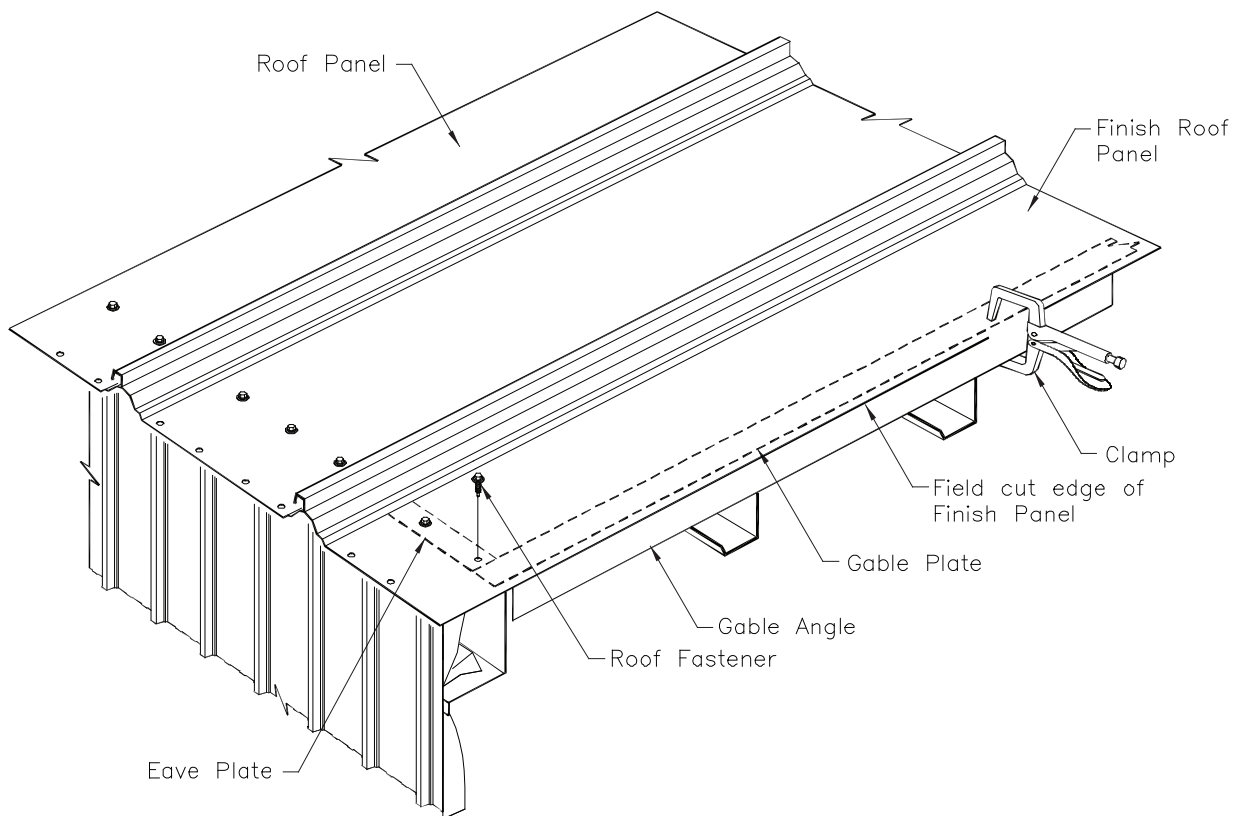

#### 9.5.2 INSTALL TERMINATION PANEL

Remove the protective paper from the gable plate sealant.

Field cut the termination roof panel to the required width. The cut edge of the panel should extend 1" beyond the outer edge of the gable plate's top flange.

Along the cut edge of the termination roof panel, wipe the underside clean and dry.

Install the termination panel into position as shown.

Install the eave fasteners and temporarily clamp the edge of the panel to the gable plate.

## 9.0 ROOF INSTALLATION DETAILS

### 9.5 TERMINATION PANEL INSTALLATION

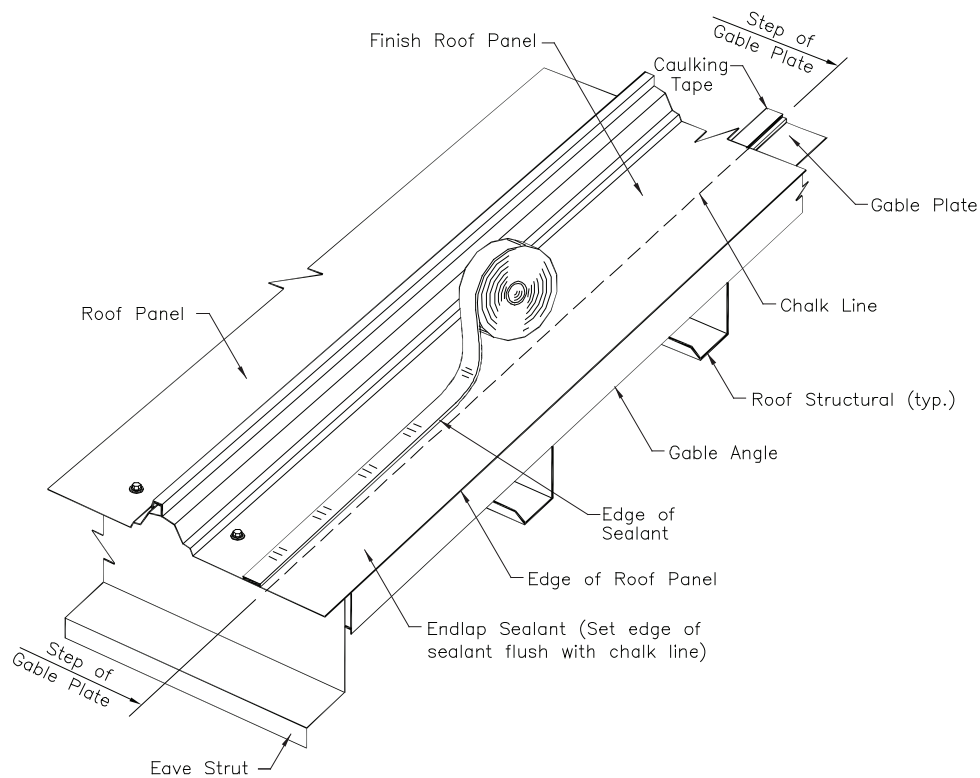

#### 9.5.3 INSTALL TERMINATION ZEE SEALANT

Along the cut edge of the termination roof panel, wipe the top surface clean and dry.

Install sealant continuous along the edge of the termination roof panel as shown.

The gable closure sealant must be positioned directly over the gable plate's top flange. Layout the sealant location on the panel's top surface with a chalk line as shown. Align the chalk line with the gable plate's step.

Position the edge of the sealant on the chalk line. Start and finish the ends of the sealant flush with the ends of the roof panel.

Check the entire length of the caulking tape to assure that it is correctly positioned and that there are no voids or thinned areas.

After the sealant has been correctly installed, lightly press the sealant against the roof panel to assure adhesion. Do not use excess pressure which can thin the sealant.

## 9.0 ROOF INSTALLATION DETAILS

### 9.5 TERMINATION PANEL INSTALLATION

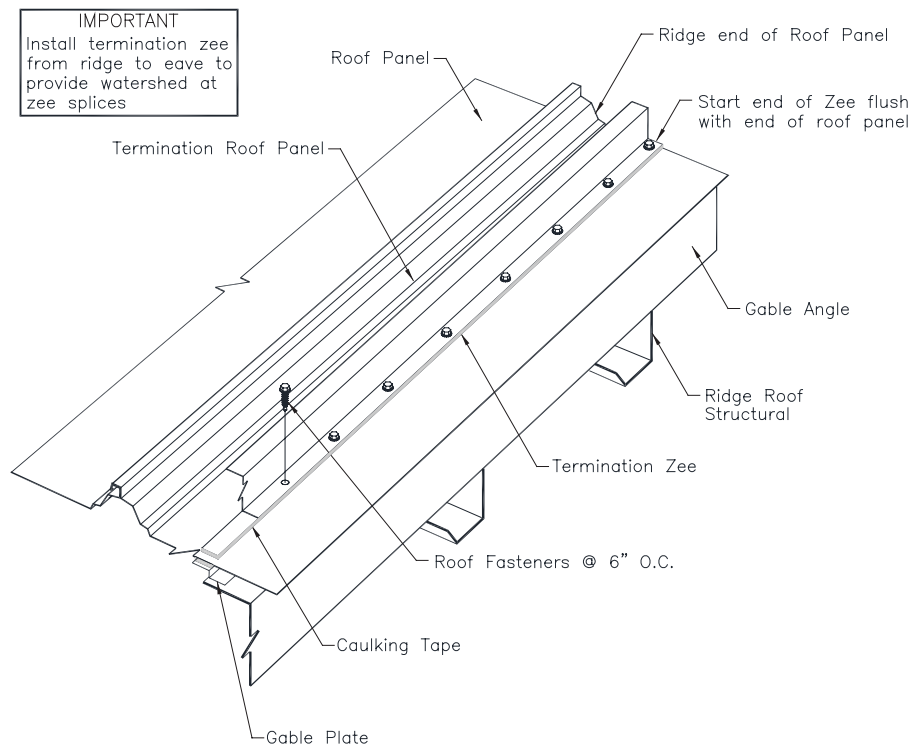

#### 9.5.4 START TERMINATION ZEE AT RIDGE

The termination zee must be installed from ridge-to-eave to provide for watershed at the termination zee splices.

Install the termination zee on top of the sealant as shown.

Position the zee so its bottom flange is turned outward and its inside edge is flush with the inside edge of the caulking tape. Position the end of the zee flush with the end of the roof panel.

Uniformly press the zee against the caulking tape to assure adhesion.

Attach the termination zee with roof fasteners at 12" spacing. Check that the fasteners penetrate the center of the sealant and securely engage the gable plate.

## 9.0 ROOF INSTALLATION DETAILS

### 9.5 TERMINATION PANEL INSTALLATION

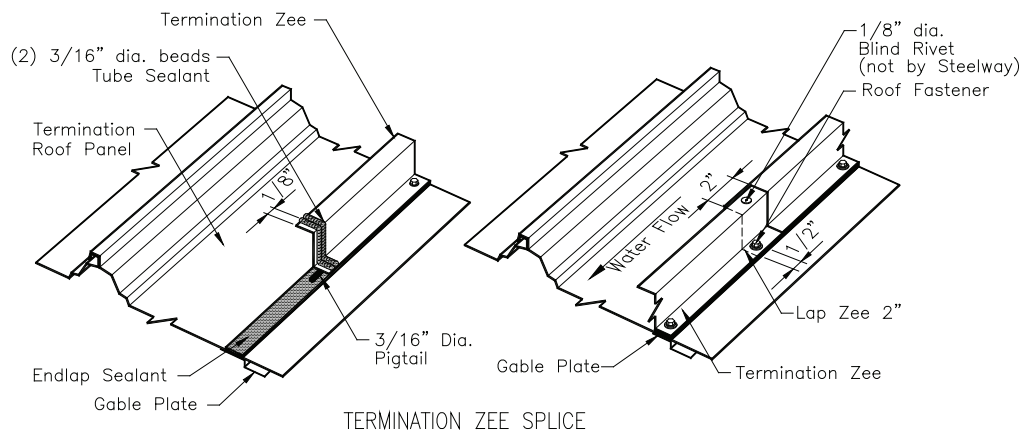

TERMINATION ZEE SPLICE

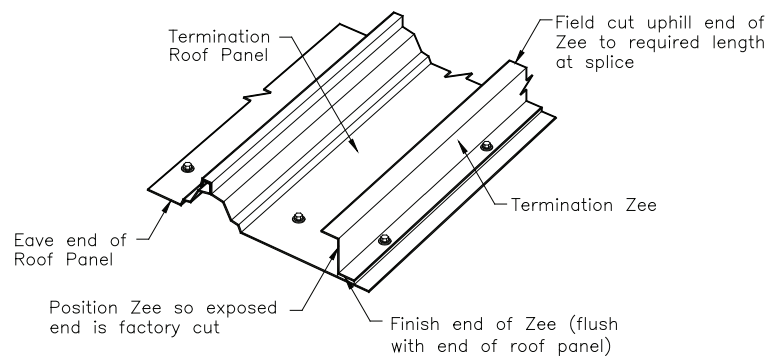

TERMINATION ZEE AT EAVE

#### 9.5.5 TERMINATION ZEE ASSEMBLY AT SPLICE & EAVE

Apply two 3/16" beads of tube caulking along the downslope end of the termination zee as shown.

Position the next zee, overlapping the previously installed zee by 2".

Clamp the lapped zee while installing the fasteners.

Attach the next zee with roof fasteners. Install the first fastener through the lapped bottom flanges.

Install a 1/8" pop rivet through the lapped upper flanges.

Position the last zee so its down slope end is flush with the eave end of the roof panel. Then cut the up-slope end for a 2" lap at the splice.

## 9.0 ROOF INSTALLATION DETAILS

### 9.6 END DAM INSTALLATION

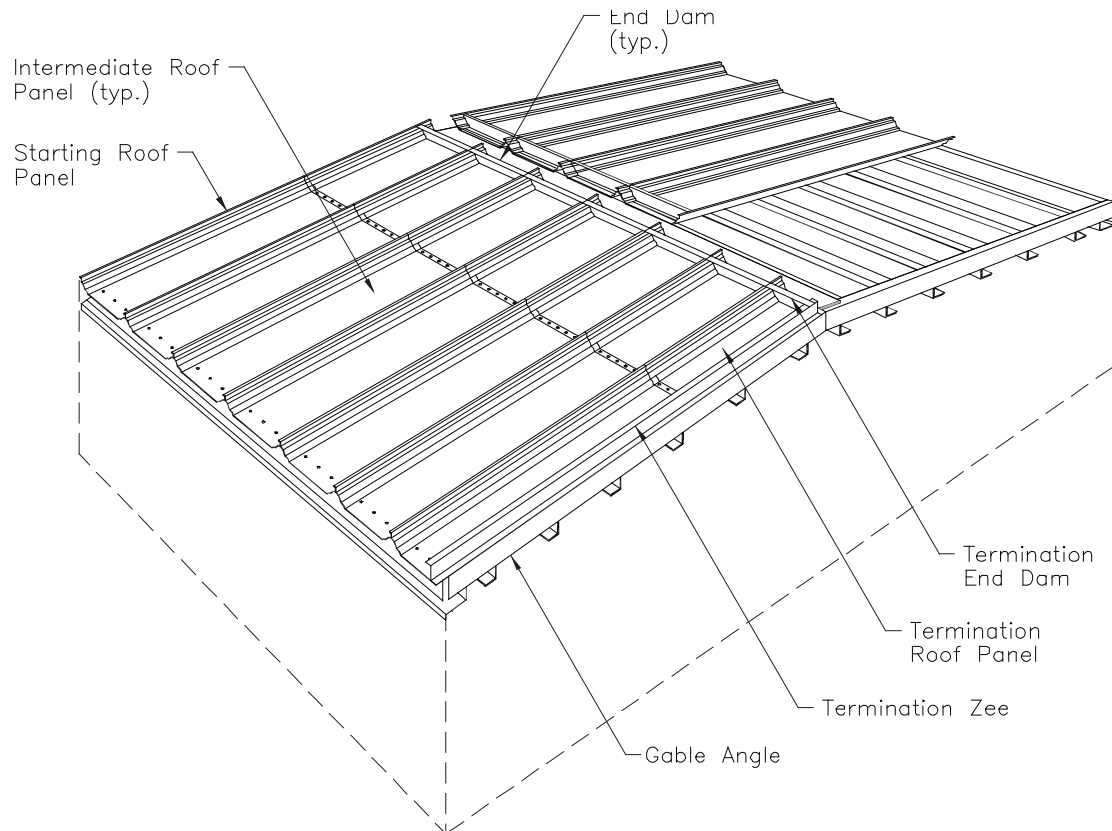

#### 9.6.1 ORIENTATION VIEW

Metal end dams are used to close the ends of the roof panels at the ridge, high eave and high eave transition conditions.

The details in this section will show the installation of the end dams and the preparation of the roof panels for installation of the end dams.

It is recommended that the end dams be installed as each roof panel run is completed. Installation of the end dams helps maintain the correct roof panel coverage at the ridge. If the end dams are installed after the roof panels are in place, roof panel coverage error may prevent proper installation of the end dams. If end dams are to be installed after roof panels are in place, the erector must ensure proper modularity of roof panels at the ridge.

As a minimum, a back-up plate and end dam should be clamped in place before last sheet installed is fastened to purlins. The back-up plate and end dam can then be unclamped and moved up to the next roof sheet.

## 9.0 ROOF INSTALLATION DETAILS

### 9.6 END DAM INSTALLATION

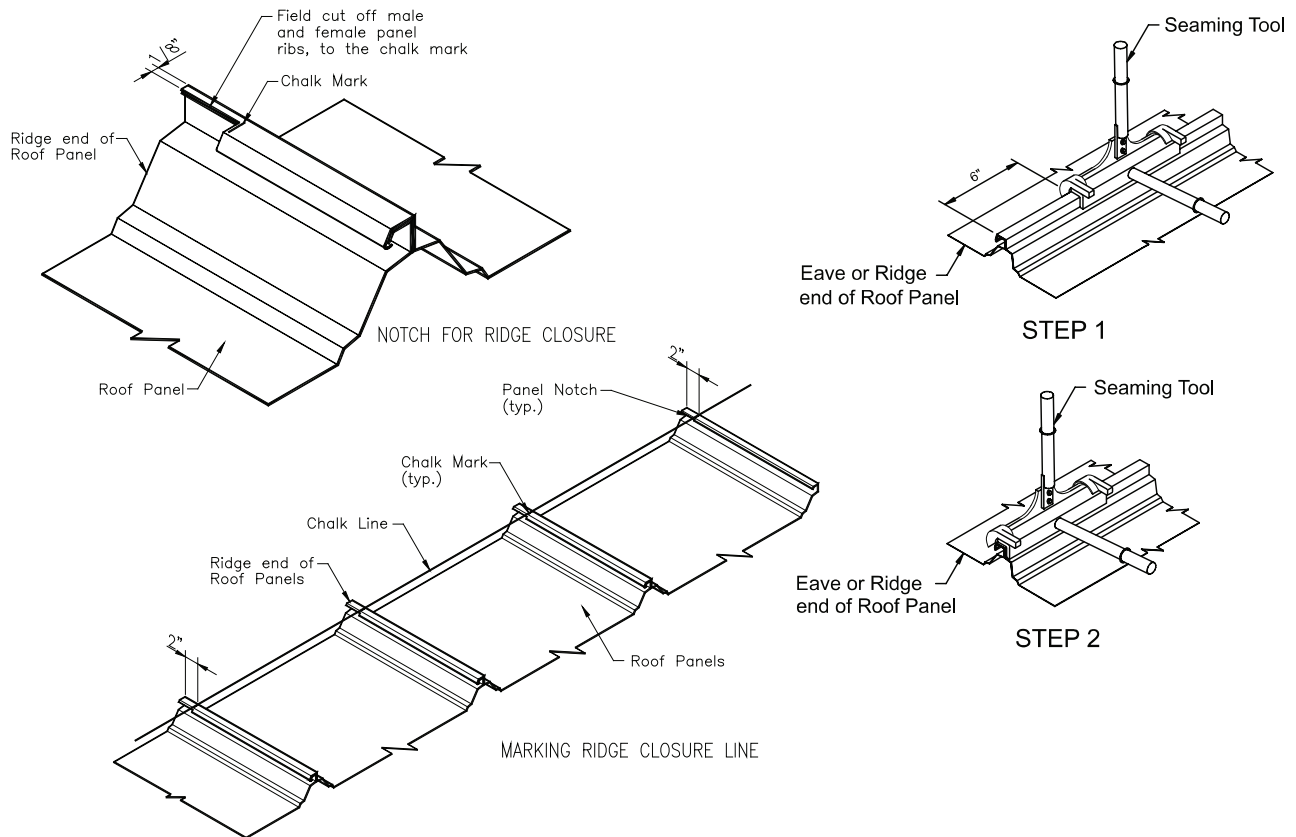

#### 9.6.2 PREPARATION FOR END DAM INSTALLATION

Check the alignment of the roof notches along the ridge. If the notches are staggered more than  $1/4"$ , use a chalk line to establish a straight notch line. Position the chalk line so no notch extends below the line.

Using the end of the factory notch (or chalk marks) as a guide, field cut the additional notching in both male and female portions of the seam as shown. Do not just cut down slope portion of notch and bend rib over. This will cause modularity problems and end dam fit-up problems.

Hand seam 16" of uphill panel end before installing tape sealant and end dam to accommodate motor seamer.

## 9.0 ROOF INSTALLATION DETAILS

### 9.6 END DAM INSTALLATION

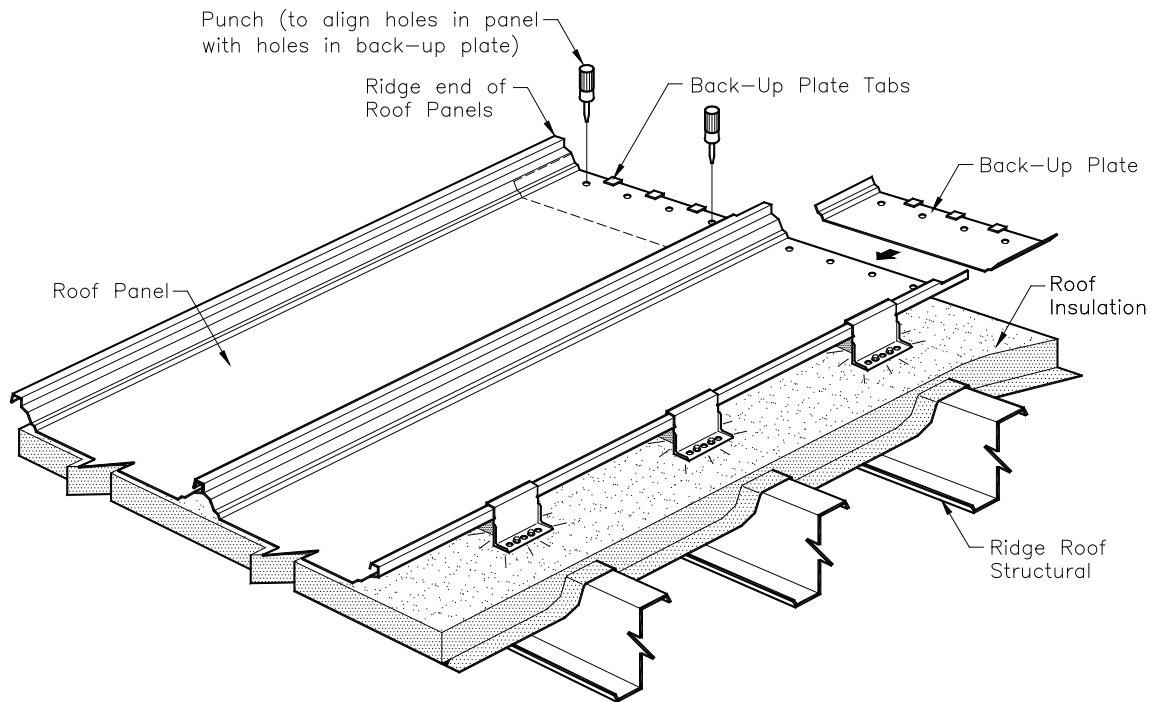

#### 9.6.3 INSTALL BACK-UP PLATE

Slide the back-up plate under the roof panel as shown.

The back-up plate must be set over the top of the roof structural. If insulation thermal blocks are used, the back-up plate must be set over the thermal block.

The back-up plate's tabs must hook over the end of the roof panel.

Use punches to align the holes in the back-up plate with the factory punched holes in the roof panel.

If the ridge purlin is located too far down slope for the back-up plate to rest on the purlin or spacer block, use a clamp to hold the back-up plate in position until after the fasteners are installed.

## 9.0 ROOF INSTALLATION DETAILS

### 9.6 END DAM INSTALLATION

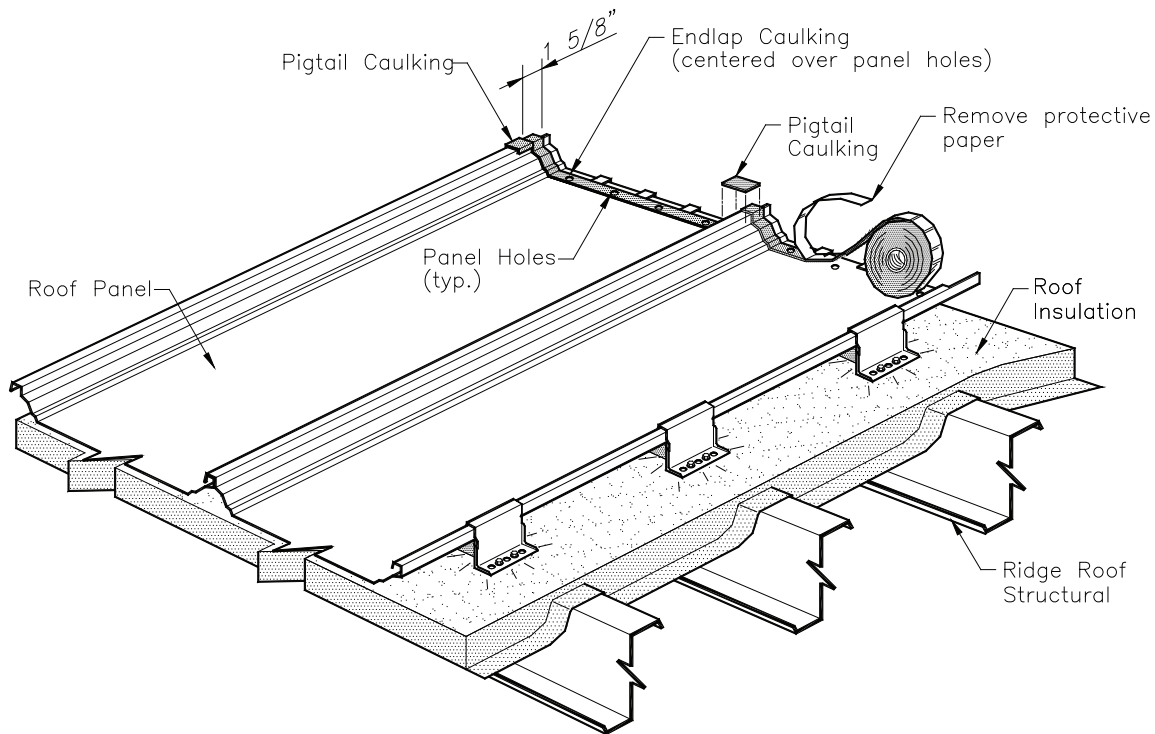

#### 9.6.4 INSTALL RIDGE SEALANT

Before installing the caulking tape, the roof panel's surface must be wiped clean and dry.

Install a continuous strip of caulking tape along the end of the roof panel as shown.

Position the caulking tape so that its downslope edge is uniformly 1 5/8" from the end of the panel. The caulking tape must be centered over the roof panel's factory punched holes.

Check that the caulking tape fully contacts the roof panel's surface and that it is completely fitted into the panel corners and around the seams

Cut a strip of caulking tape and install as the pigtail sealant as shown.

Specific caulking tape details are shown on the following page.

## 9.0 ROOF INSTALLATION DETAILS

### 9.6 END DAM INSTALLATION

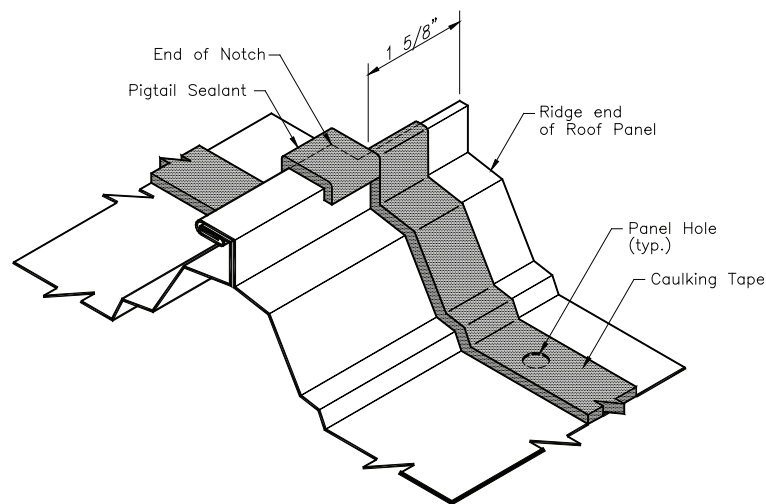
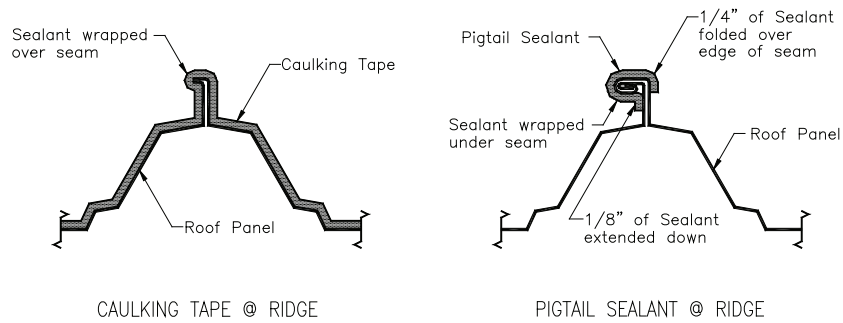

#### 9.6.5 RIDGE SEALANT DETAILS

The correct installation of the ridge sealant is critical to the weather resistance of the roof system.

Be sure to verify that the sealant is installed as shown above before installing end dams.

After the sealant is correctly positioned, uniformly press the sealant against the roof panel's surface to assure adhesion. Do not use excess pressure, which can thin the sealant.

## 9.0 ROOF INSTALLATION DETAILS

### 9.6 END DAM INSTALLATION

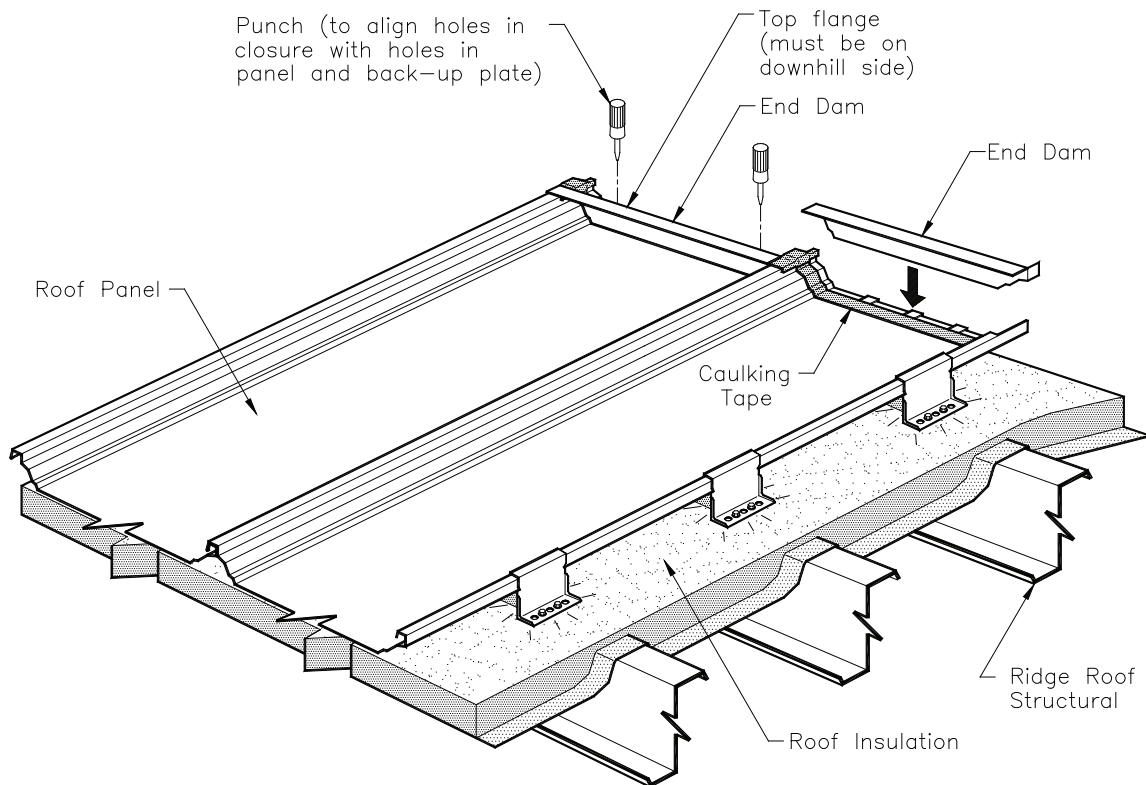

#### 9.6.6 INSTALL END DAMS

Wipe dry and clean the underside surface of the end dam flanges.

Remove the protective paper from the installed ridge sealant.

Position the end dam so its bottom flange is turned up-slope and its top flange is downslope.

Position the end dam's bottom flange directly over the ridge caulking tape and use punches to align the holes in the end dam with the factory punched holes in the roof panel and back-up plate.

Be careful not to displace or damage the caulking tape while installing the end dam and punches.

## 9.0 ROOF INSTALLATION DETAILS

### 9.6 END DAM INSTALLATION

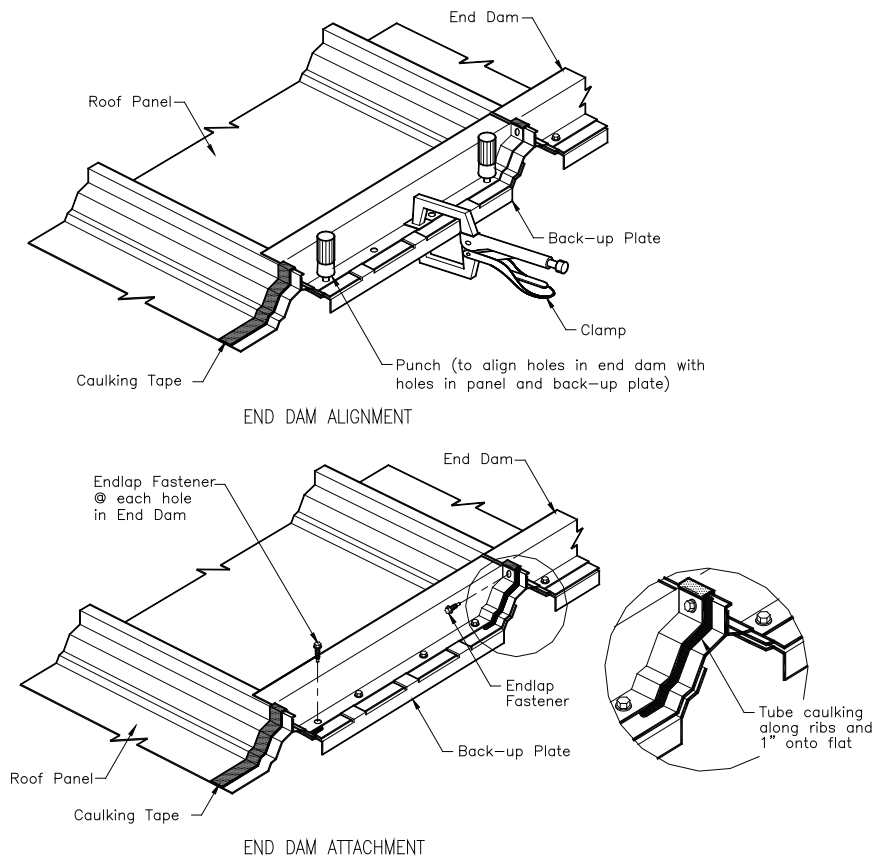

#### 9.6.7 END DAM ATTACHMENT

While the matching holes are aligned by the punches, uniformly press the end dam into the ridge caulking tape to assure adhesion. Use a clamp to hold the assembly together while installing the fasteners. Install endlap fasteners through the holes in the end dam's bottom flange.

Check that the fasteners penetrate through the center of the ridge caulking tape and are securely engaged into the back-up plate.

Check that the face of the end dam is perpendicular to the roof panel and aligned with the previously installed end dams. If not, push the top of the end dam to the correct position.

Install a lap fastener through the hole at the top of the end dam, through the roof panel seam and into the hole in the opposite end dam.

Apply tube caulking on back edge of end dam along panel ribs (both sides) and 1" onto flat part of panel.

#### **IMPORTANT**

Over tightening this fastener will squeeze the roof panel sidelap assembly together and may affect the roof panel's coverage width. Carefully tighten the fastener only as necessary to maintain the correct panel width.

## 9.0 ROOF INSTALLATION DETAILS

### 9.6 END DAM INSTALLATION

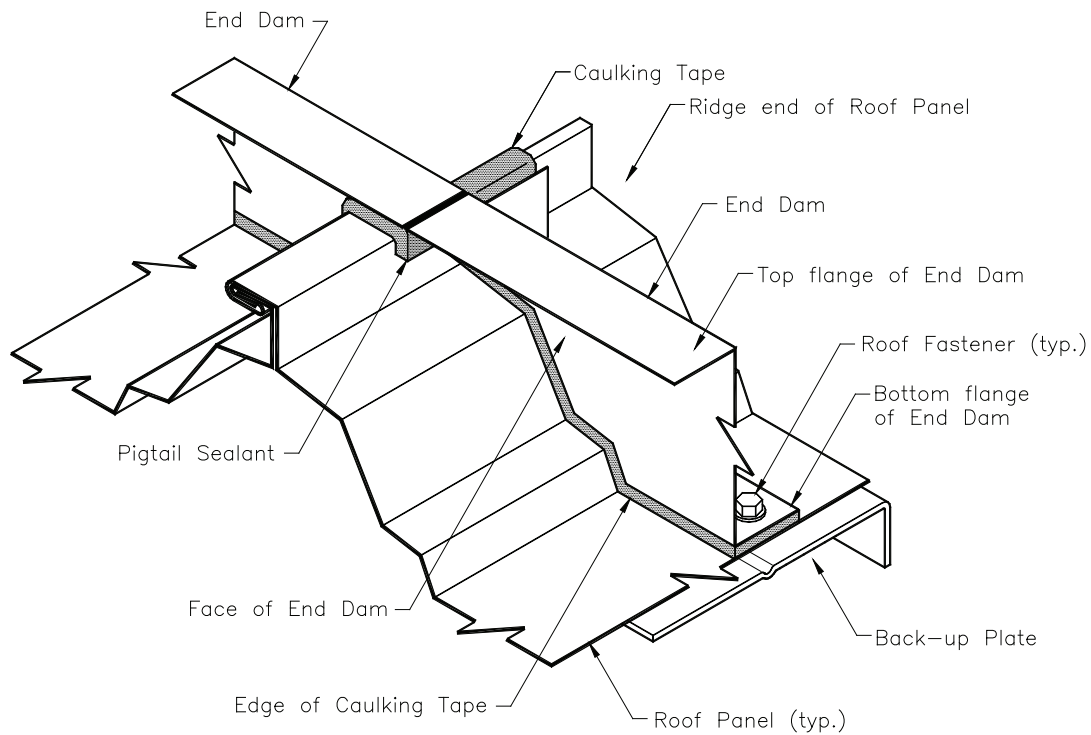

#### 9.6.8 END DAM ASSEMBLY

Verify that the end dam is correctly assembled as shown.

Check that there are no un-sealed voids between the roof panel and the end dam, especially in the critical areas around the roof panel ribs and seams.

## 9.0 ROOF INSTALLATION DETAILS

### 9.6 END DAM INSTALLATION

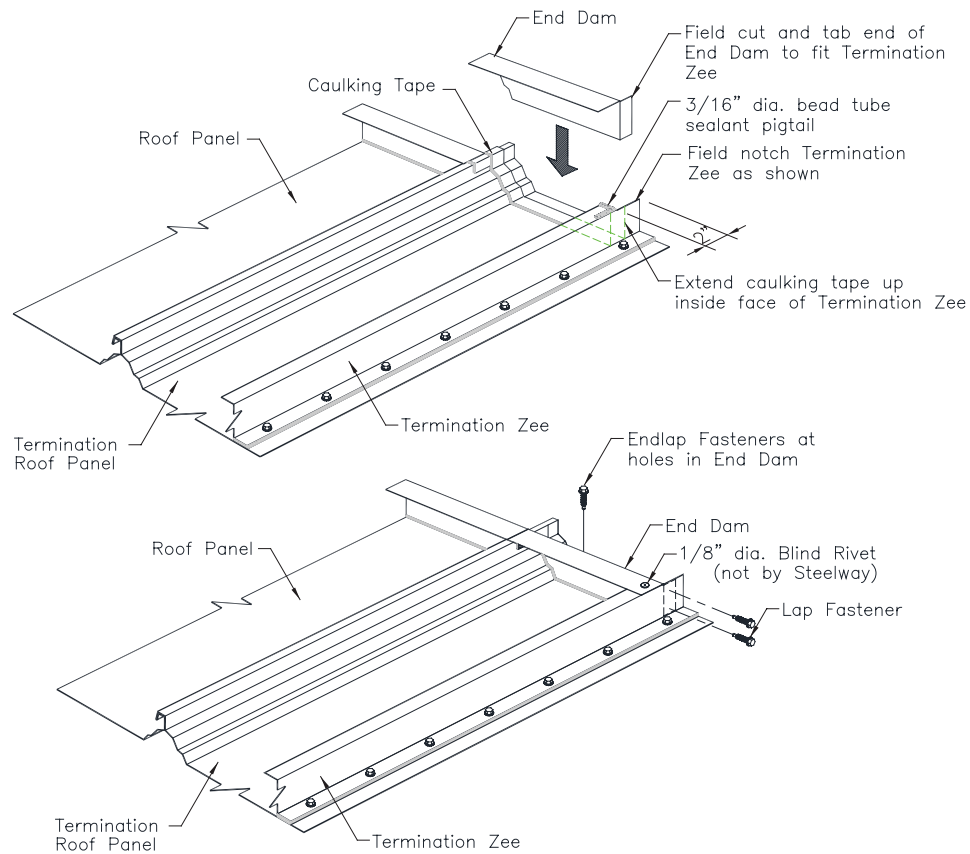

#### 9.6.9 INSTALL TERMINATION END DAM

An end dam must be field modified to fit between the roof panel rib and the termination zee.

Install the ridge caulking tape to extend up the face of the termination zee as shown.

Field modify the end dam as shown above and install as shown.

## 9.0 ROOF INSTALLATION DETAILS

### 9.7 EAVE TRIM INSTALLATION

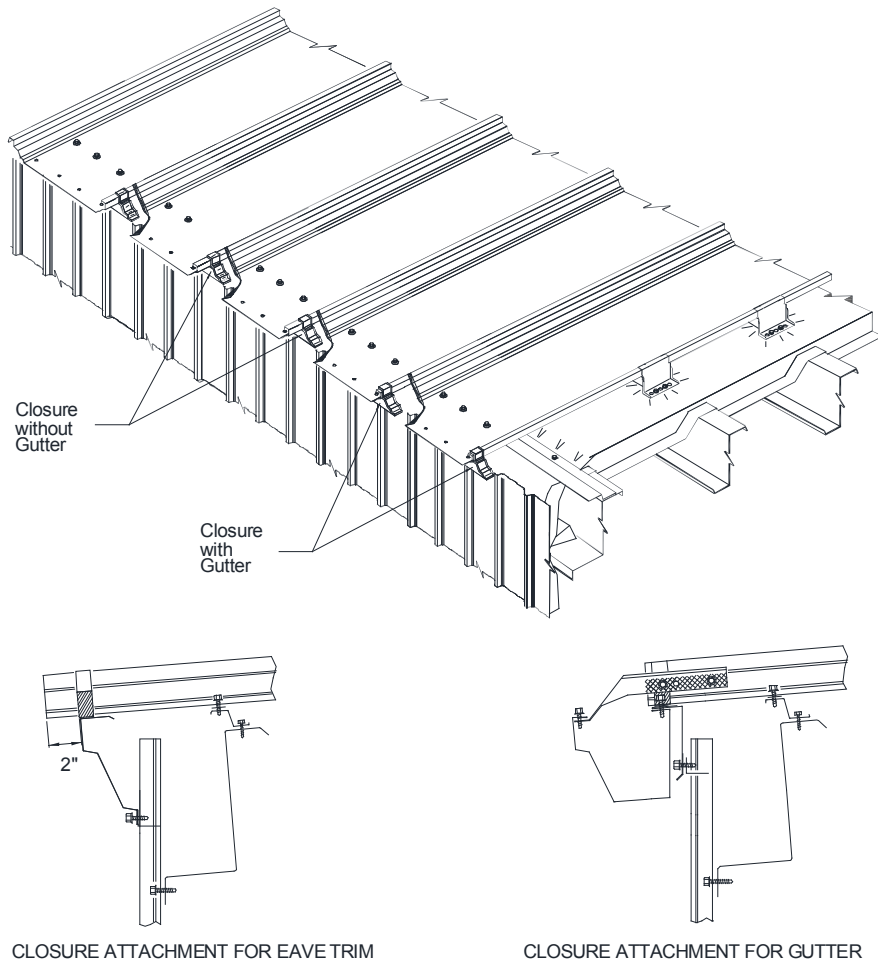

#### 9.7.1 CLOSURE LOCATION FOR EAVE TRIM

Refer to section 9.3.5 for closure details. The closure has to be installed 2" beyond the leading edge of roof panel.

Verify that the closures are correctly assembled as shown above or in the erection drawings.

The distance between the girt line and the edge of the roof panel will differ depending on whether there is a standard eave trim or a gutter. (Refer to erection details)

For the gutter installation see section 9.12.

## 9.0 ROOF INSTALLATION DETAILS

### 9.7 EAVE TRIM INSTALLATION

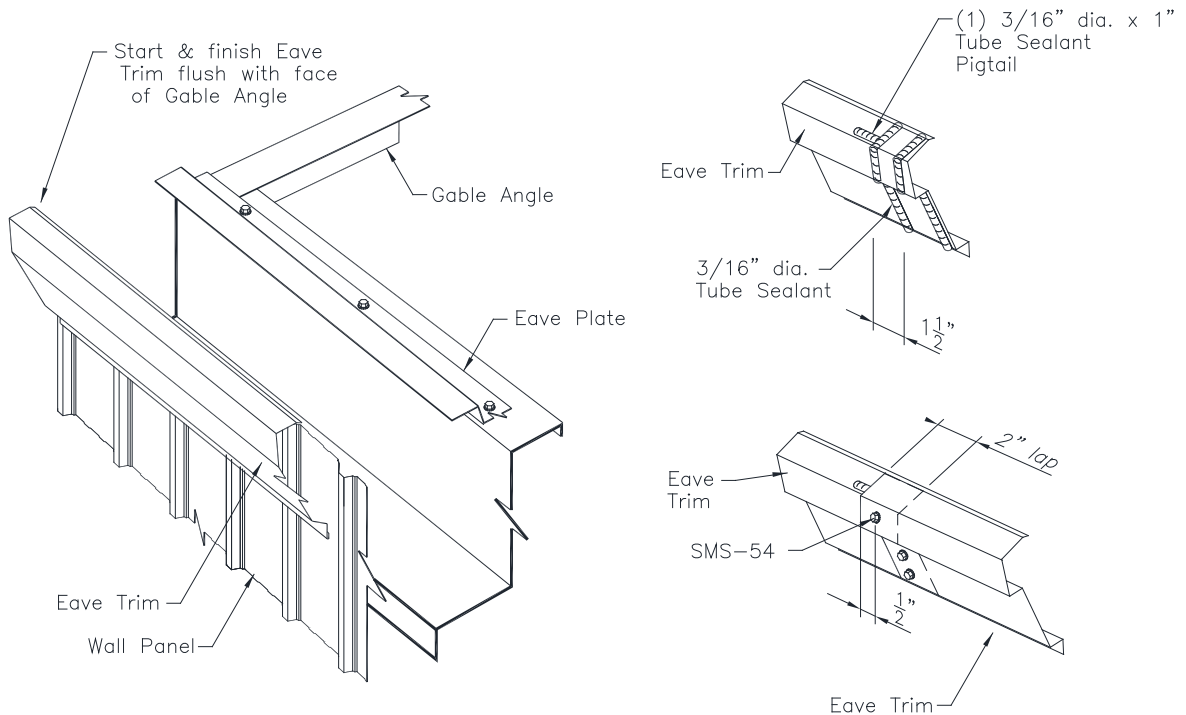

STARTING EAVE TRIM

Note: for clarity of detail,  
roof insulation is not shown.

EAVE TRIM SPLICE

#### 9.7.2 INSTALL EAVE TRIM

Align the face of the eave trim with the face of the wall panel.

The eave trim provides a water seal between the roof panel and the wall panels. All laps of the eave trim must be sealed with tube sealant and rivets as shown to minimize water entry.

Install eave trim so that front edge of trim is even with the outside edge of the metal void closure. Do not fasten last 4'-0" of trim until the next trim has been correctly lapped.

## 9.0 ROOF INSTALLATION DETAILS

### 9.7 EAVE TRIM INSTALLATION

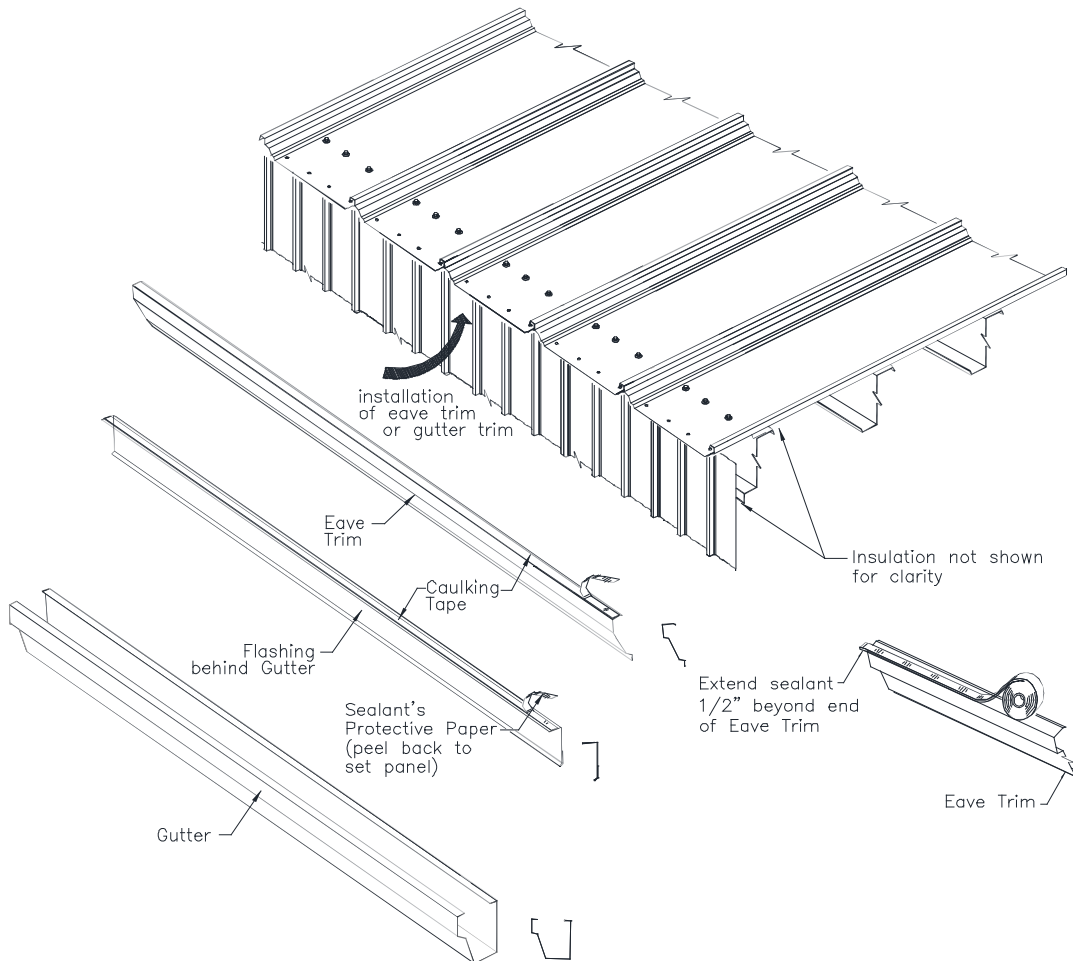

#### 9.7.3 INSTALL CAULKING TAPE

Apply a continuous strip of caulking tape along the top edge of the eave trim.

Align the outer edge of the tape, flush with the outer edge of the eave trim.

## 9.0 ROOF INSTALLATION DETAILS

### 9.7 EAVE TRIM INSTALLATION

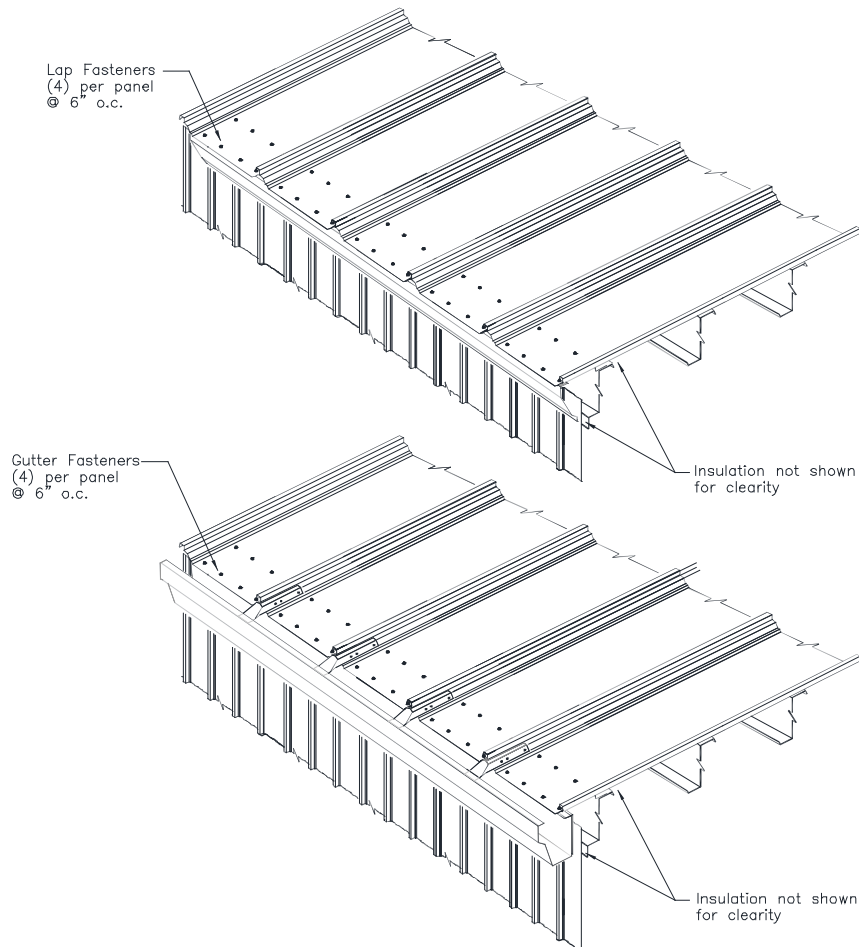

#### 9.7.4 FASTENING EAVE TRIM

Peel back the protective paper from the trim sealant and fasten the eave trim or the flashing behind the gutter with lap fasteners to the underside of the roof panel as shown above and in the erection drawings. Fasten the gutters back flange to the underside of roof panel as shown.

Check that the lap fasteners are securely engaged into the eave trim or into the gutter's back flange.

In areas with heavy ice and snow accumulations it is recommended that heat trace cables be installed on the roof to prevent excessive build-up of ice and snow.

## 9.0 ROOF INSTALLATION DETAILS

### 9.8 GABLE TRIM INSTALLATION

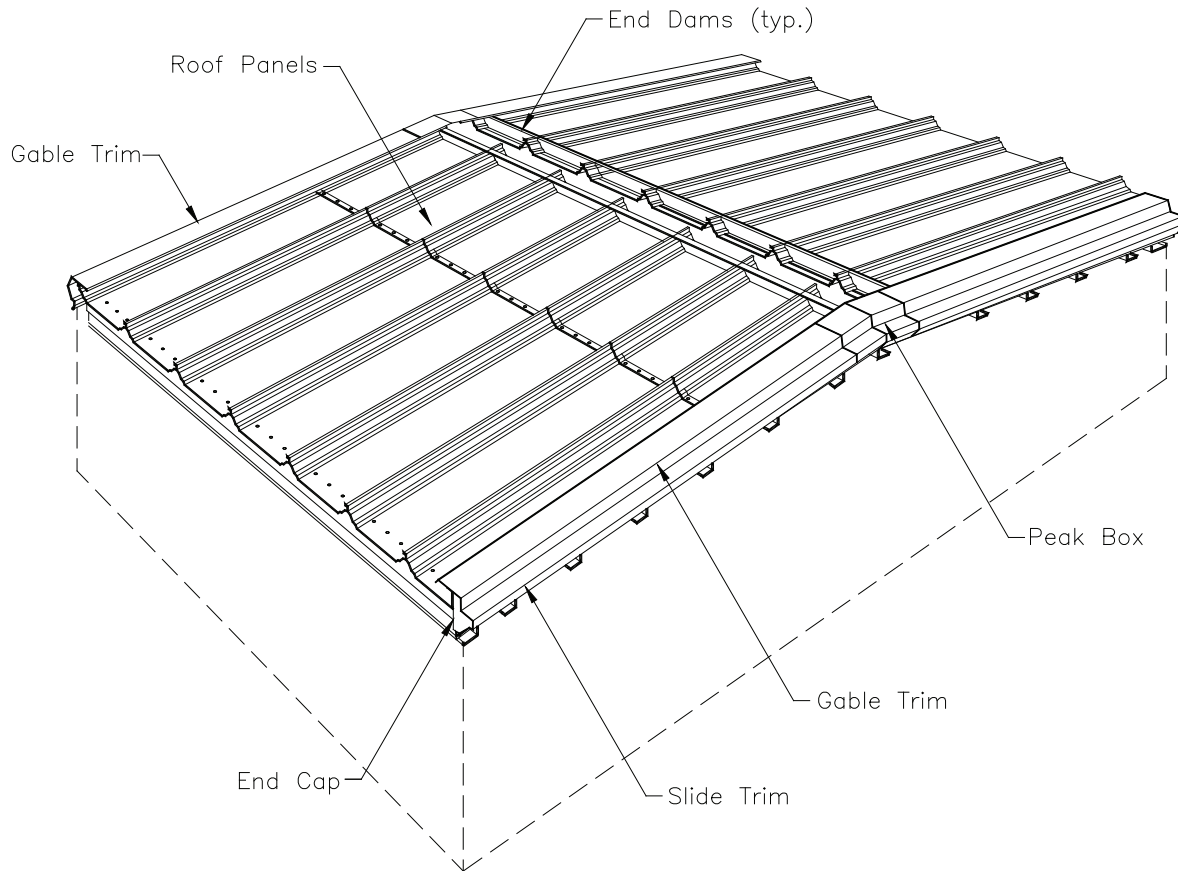

#### 9.8.1 ORIENTATION VIEW

The details in this section show the installation at the gable trim, peak box and end caps.

These details show the gable trim at the start and termination roof panel condition.

## 9.0 ROOF INSTALLATION DETAILS

### 9.8 GABLE TRIM INSTALLATION

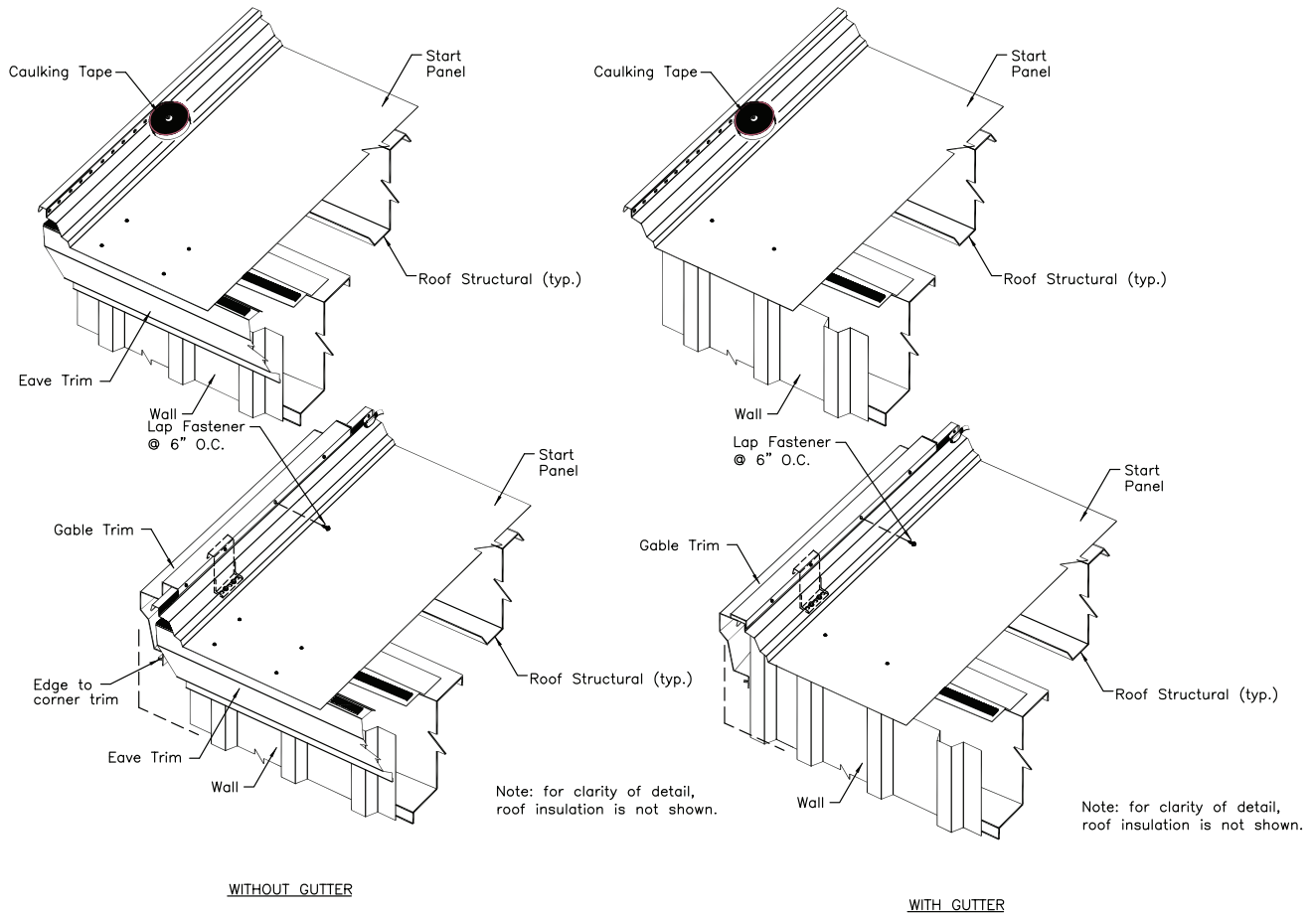

#### 9.8.2 START GABLE TRIM (START TRIM AT LOW EAVE)

Install start gable trim from eave to ridge to provide for watershed at the splices.

Install caulking tape along front side of panel. Start the down-slope end of the gable trim so that the gable trim is properly aligned with the face of the wall panel as shown above.

If the building has been designed with a gutter, the gable trim has to be flush with the end of the roof panel.

Fasten the start gable trim to the roof panel ribs with fasteners at 6" spacing. Ensure at least 1 fastener penetrates each start clip.

Check that the fasteners penetrate the center of the caulking tape and securely engage the panel rib.

## 9.0 ROOF INSTALLATION DETAILS

### 9.8 GABLE TRIM INSTALLATION

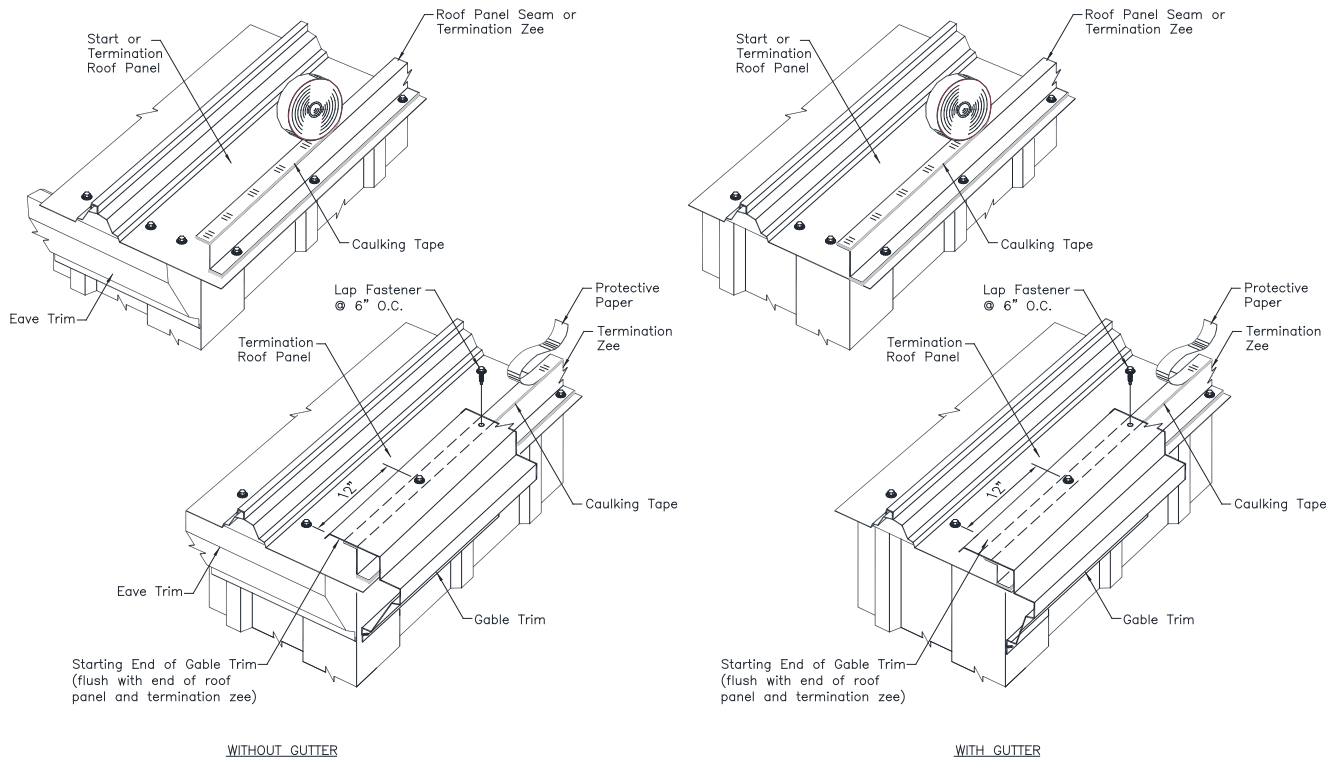

#### 9.8.3 TERMINATION GABLE TRIM (START TRIM AT LOW EAVE)

Install termination gable trim from eave to ridge to provide for watershed at the splices.

Install caulking tape continuous along the top flange of the termination zee. Start the down-slope end of the gable trim so that the gable trim is properly aligned with the face of the wall panel as shown above.

If the building has been designed with a gutter, the gable trim has to be flush with the end of the roof panel.

Fasten the gable trim to the termination zee with lap fasteners at 6" spacing, as shown.

Check that the fasteners penetrate the center of the caulking tape and securely engage the termination zee.

## 9.0 ROOF INSTALLATION DETAILS

### 9.8 GABLE TRIM INSTALLATION

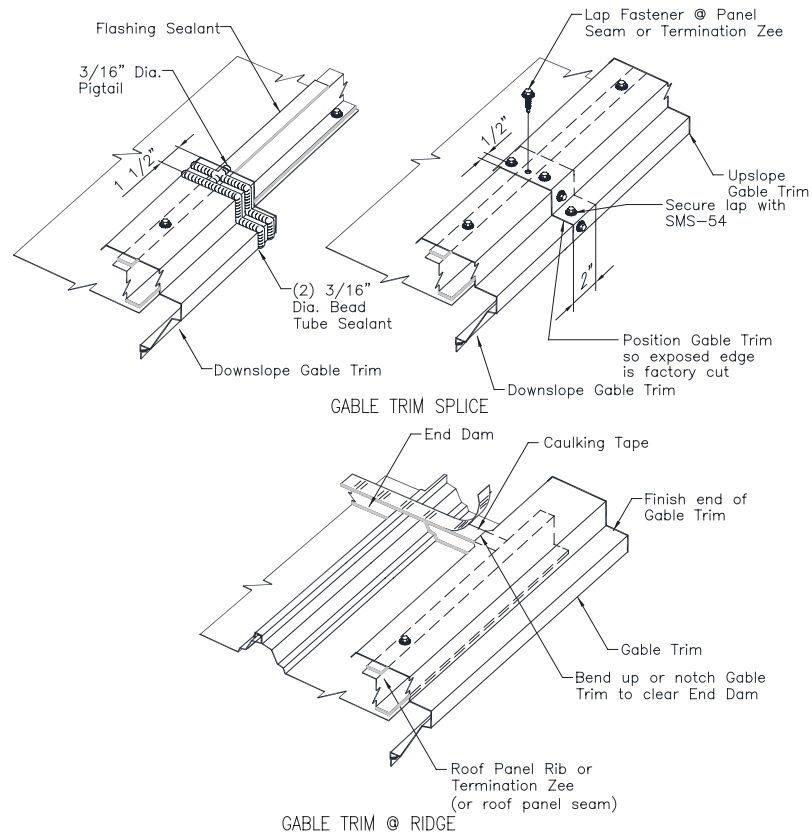

#### 9.8.4 GABLE TRIM ASSEMBLY AT SPLICE AND RIDGE

Assemble gable trim splices with tube sealant and rivets as shown.

Bend or notch the gable trim's lip to clear the top flange of the end dam.

At the ridge, field cut the end of the gable trim 2" away from the center line of the ridge.

At a high eave transition, field cut the end of the gable trim as required for a weathertight joint with the adjacent construction.

## 9.0 ROOF INSTALLATION DETAILS

### 9.8 GABLE TRIM INSTALLATION

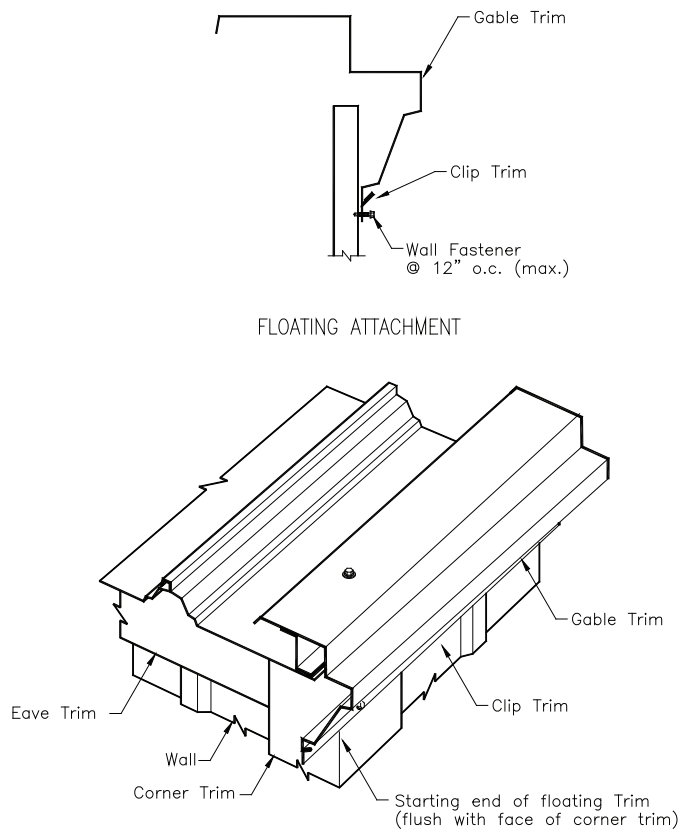

#### 9.8.5 INSTALL GABLE CLIP TRIM

For all gable trim runs the bottom edge of the gable trim must be secured with the trim clip to allow for expansion/contraction.

Install the floating clip trim continuous along the bottom edge of the gable trim as shown.

In all cases, the bottom edge of the gable trim must be installed straight and parallel to the roof line. Use a chalk line to guide the alignment of the gable trim's bottom edge.

## 9.0 ROOF INSTALLATION DETAILS

### 9.8 GABLE TRIM INSTALLATION

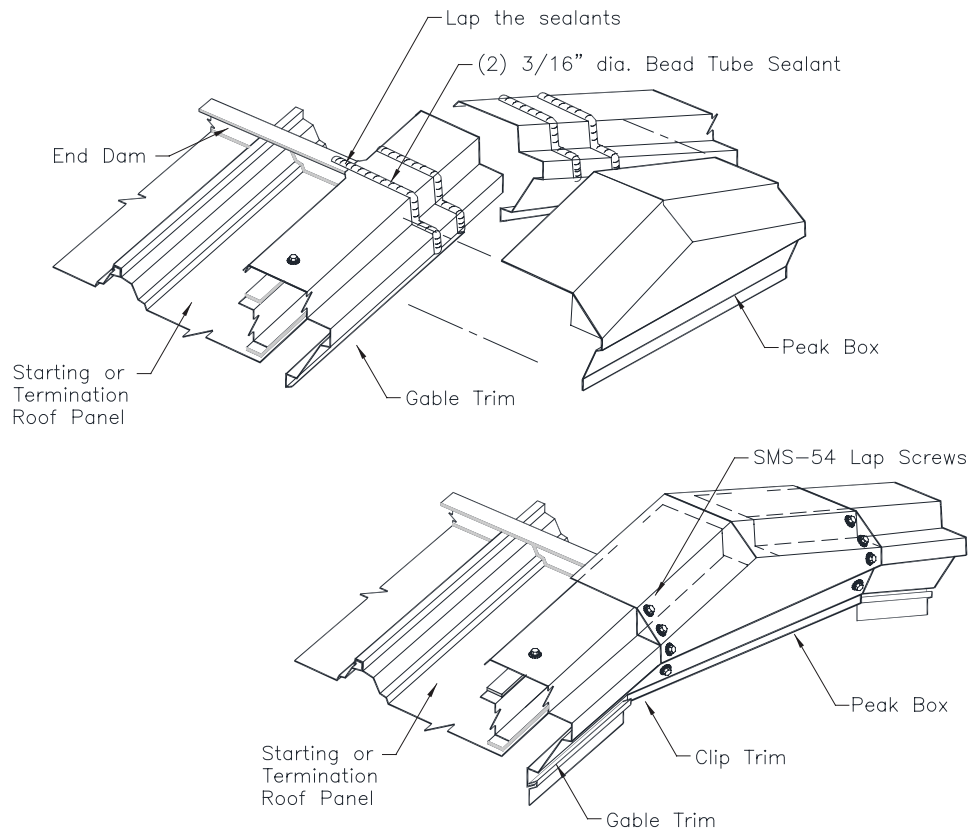

#### 9.8.6 INSTALL PEAK BOX

The peak box is installed with tube sealant and rivets in the same manner as a splice.

Secure the bottom edge of the peak box to the wall panel with fasteners.

## 9.0 ROOF INSTALLATION DETAILS

### 9.8 GABLE TRIM INSTALLATION

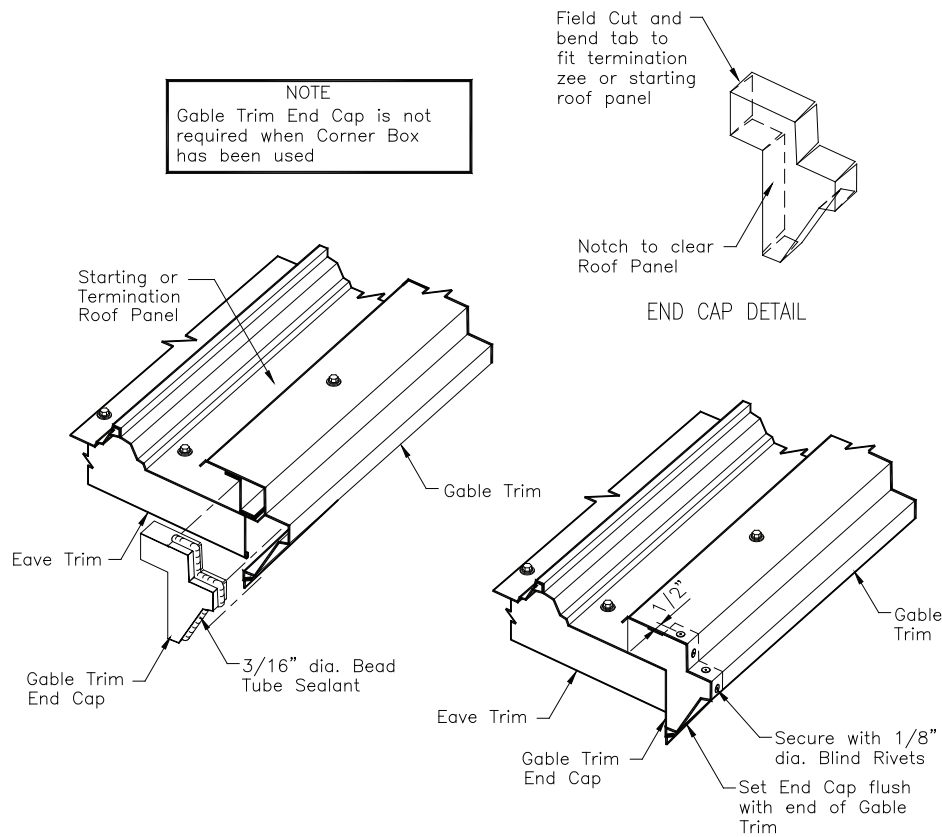

#### 9.8.7 INSTALL END CAPS

The end cap must be field cut and a tab bent to fit the termination zee or starting roof panel as shown.

Install the end cap with tube caulking and rivets in the same manner as a splice.

## 9.0 ROOF INSTALLATION DETAILS

### 9.8 GABLE TRIM INSTALLATION

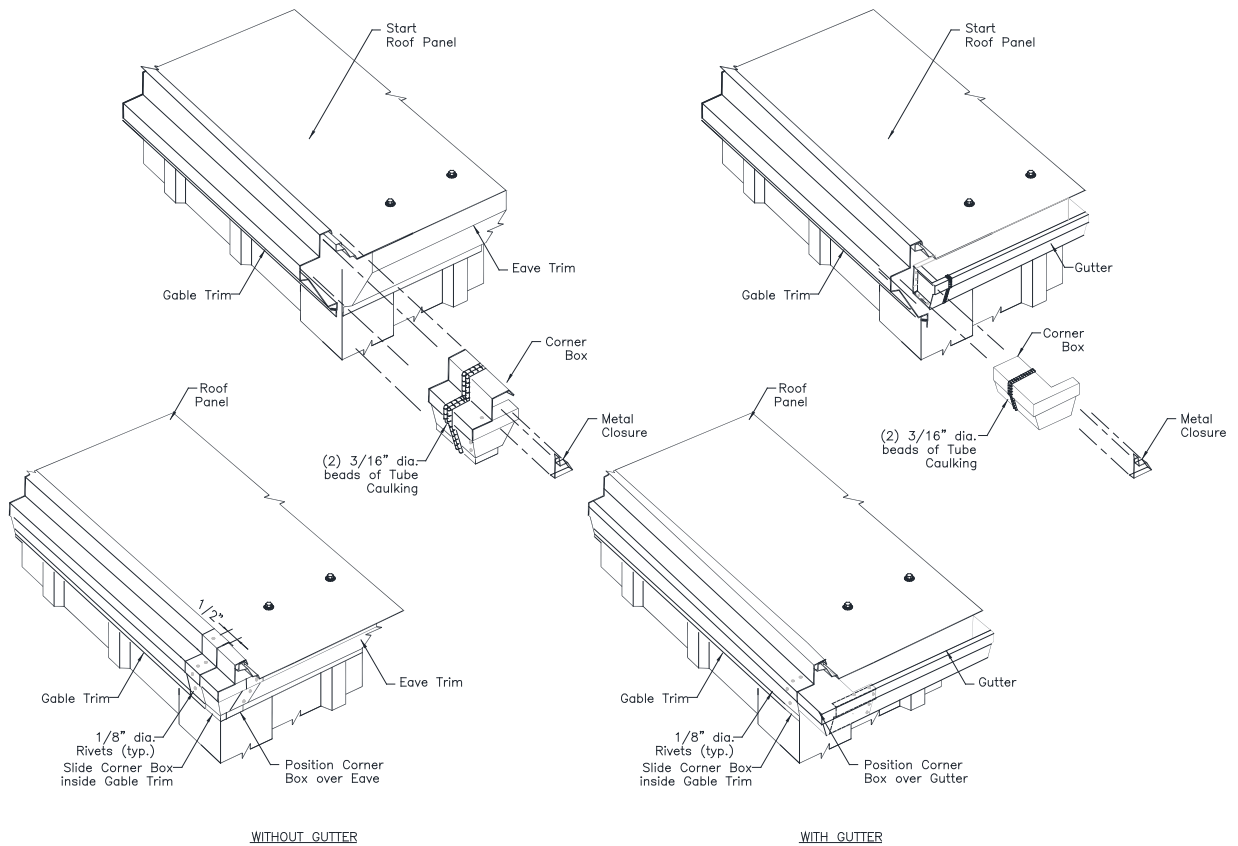

#### 9.8.8 START CORNER BOX INSTALLATION (STANDARD EAVE TRIM)

Install corner boxes and sealants as shown.

Fasten corner boxes to trims with 1/8" diameter blind rivets.

## 9.0 ROOF INSTALLATION DETAILS

### 9.8 GABLE TRIM INSTALLATION

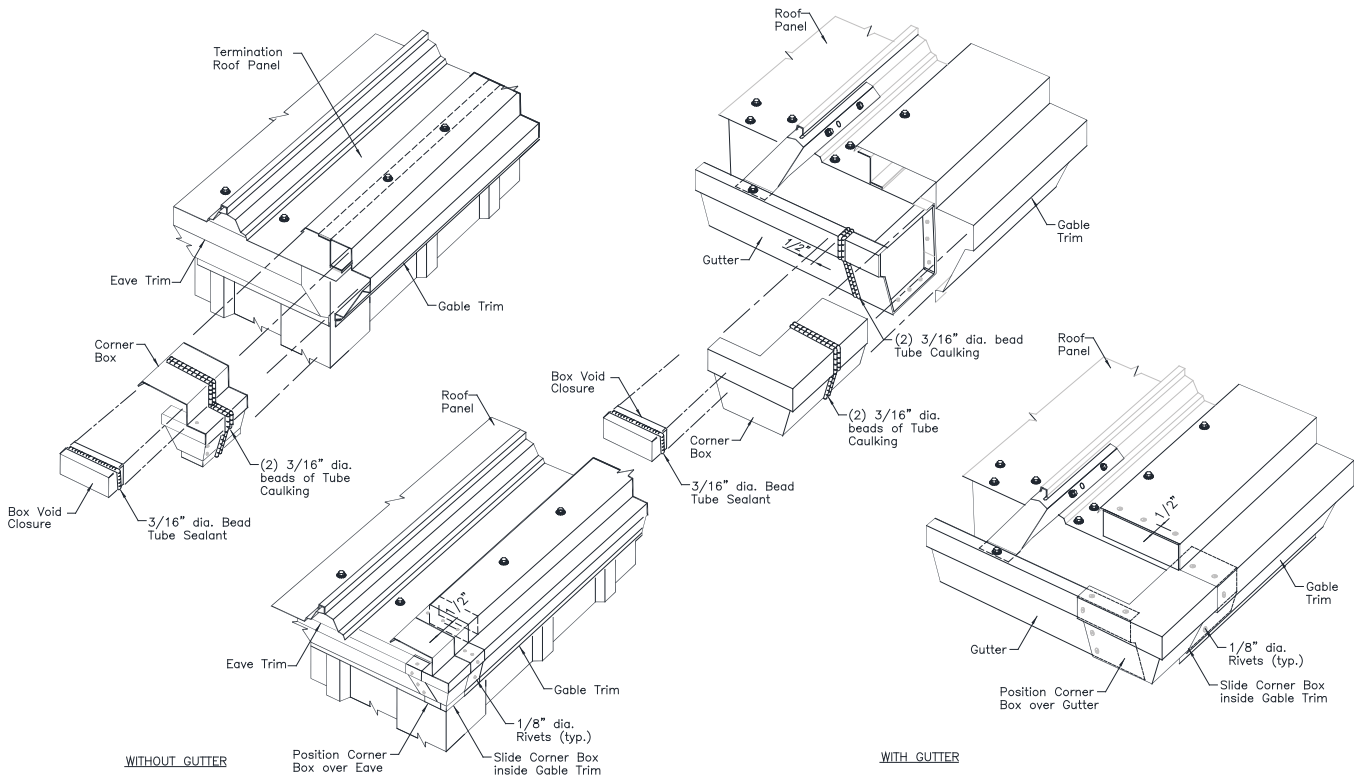

#### 9.8.9 TERMINATION CORNER BOX INSTALLATION (STANDARD EAVE TRIM)

Install corner boxes and sealants as shown.

Fasten corner boxes to trims with 1/8" diameter blind rivets.

## 9.0 ROOF INSTALLATION DETAILS

### 9.9 GABLE TRANSITION INSTALLATION

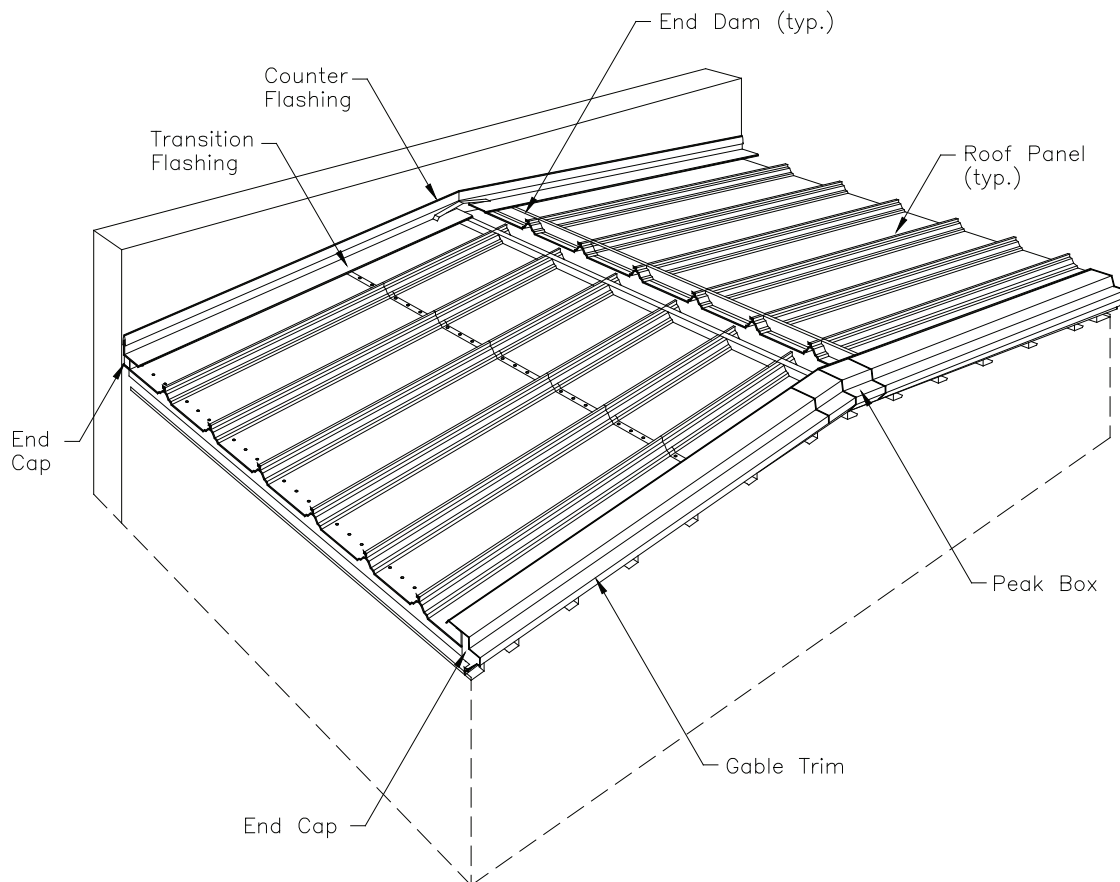

#### 9.9.1 ORIENTATION VIEW

The details in this section show the installation of the gable transition flashing.

Counter flashing details are not shown. Refer to the erection drawings for the required counter flashing.

In all cases, verify that counter flashing will:

- Allow expansion/contraction of the transition flashing.
- Restrain the transition flashing during roof live loads and wind loads.
- Provide a weather resistant seal between the transition flashing and the wall.

## 9.0 ROOF INSTALLATION DETAILS

### 9.9 GABLE TRANSITION INSTALLATION

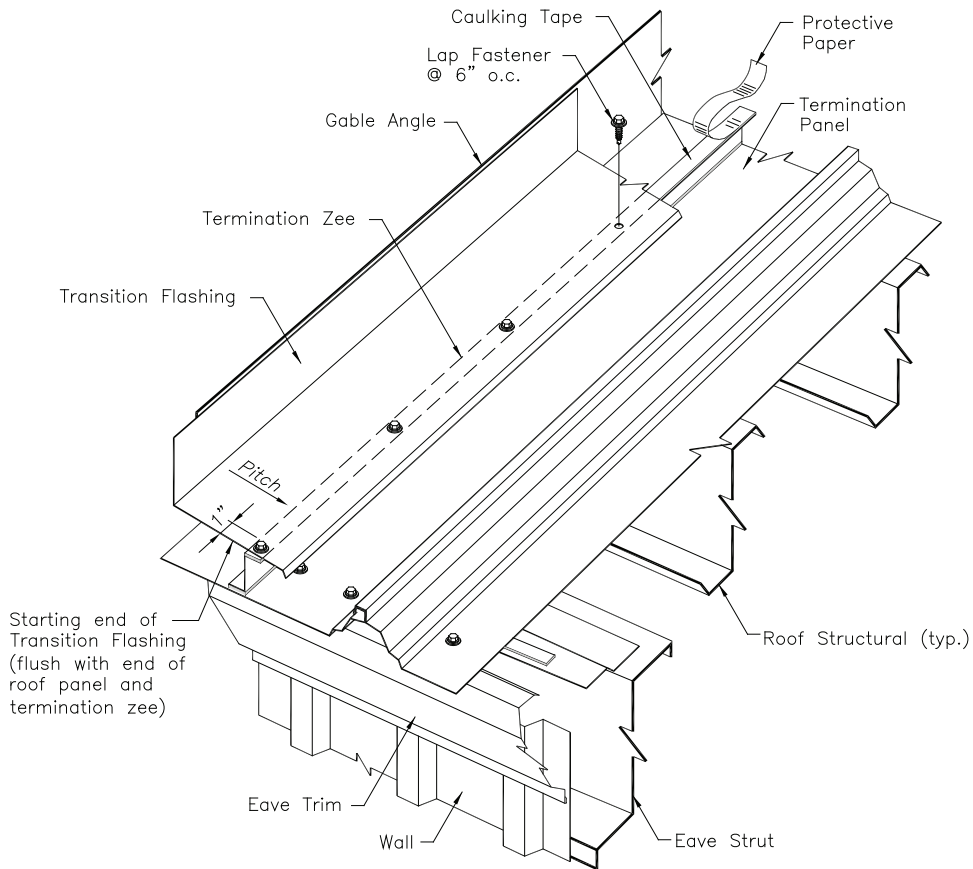

#### 9.9.2 START TRANSITION FLASHING AT EAVE

Install the transition flashing from eave to ridge to provide for watershed at the splices.

Install flashing sealant continuous along the top flange of the termination zee.

Start the downslope end of the flashing flush with the end of the roof panel and position the back leg flush with the gable angle or wall construction.

Check that the flashing is set at a positive pitch to assure watershed.

Attach the flashing to the termination zee with lap fasteners at 6" spacing as shown.

Check that the fasteners penetrate the center of the caulking and securely engage the termination zee.

## 9.0 ROOF INSTALLATION DETAILS

### 9.9 GABLE TRANSITION INSTALLATION

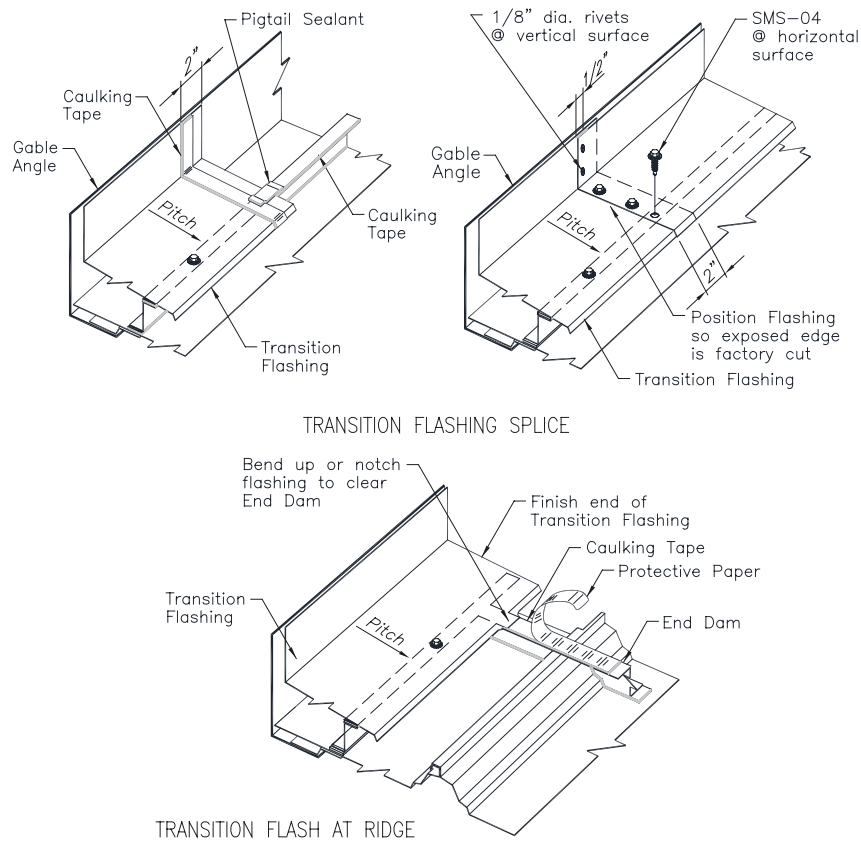

#### 9.9.3 TRANSITION FLASHING ASSEMBLY AT SPLICE AND RIDGE

Assemble transition flashing splices with caulking tape and lap fasteners as shown. Wipe dry and clean the lapping surfaces of the flashing.

Bend or notch the flashing's lip to clear the top flange of the end dam.

At the ridge, field cut the end of the flashing 2" away from the center line of the ridge.

At a high eave transition, field cut the end of the flashing as required for a weather tight joint with the adjacent construction.

## 9.0 ROOF INSTALLATION DETAILS

### 9.10 RIDGE COVER INSTALLATION

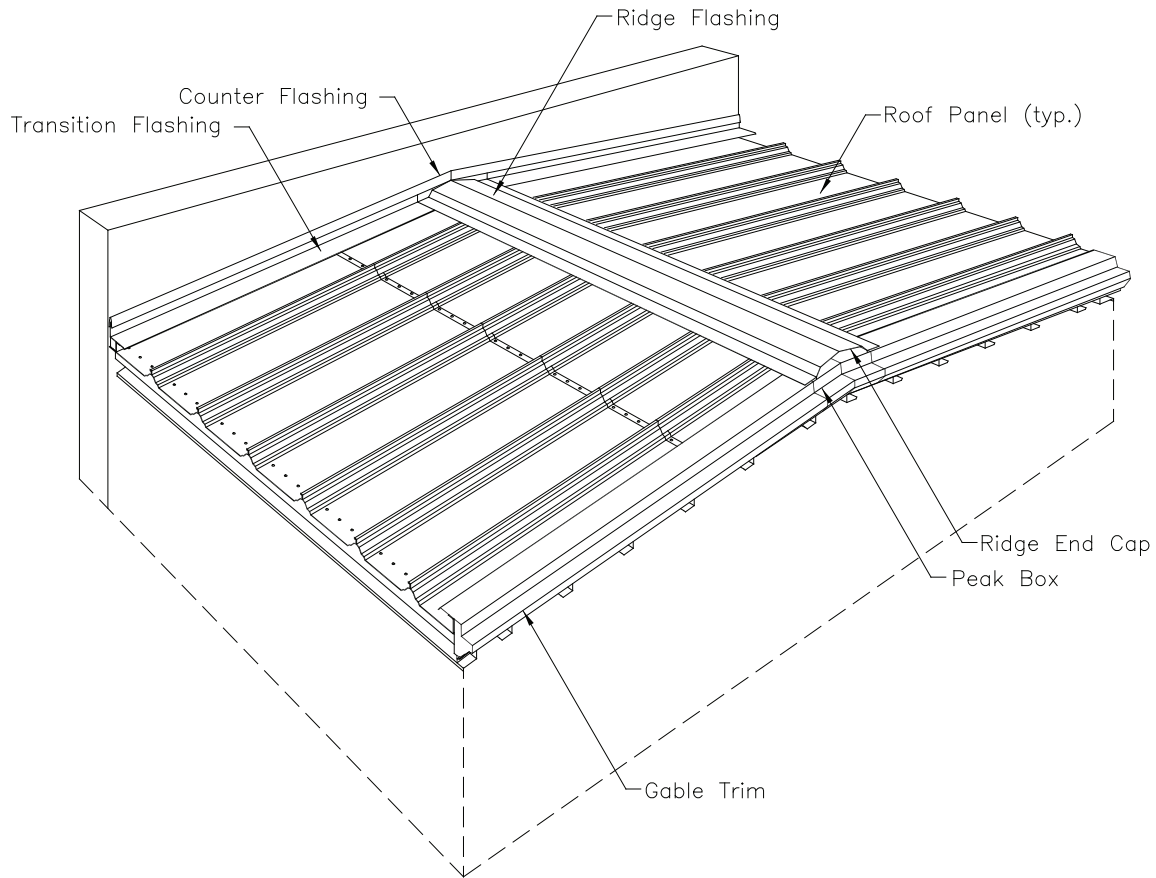

#### 9.10.1 ORIENTATION VIEW

The details in this section show the installation of the ridge cover.

The ridge cover can start or finish at either a gable trim condition or a gable transition condition.

## 9.0 ROOF INSTALLATION DETAILS

### 9.10 RIDGE COVER INSTALLATION

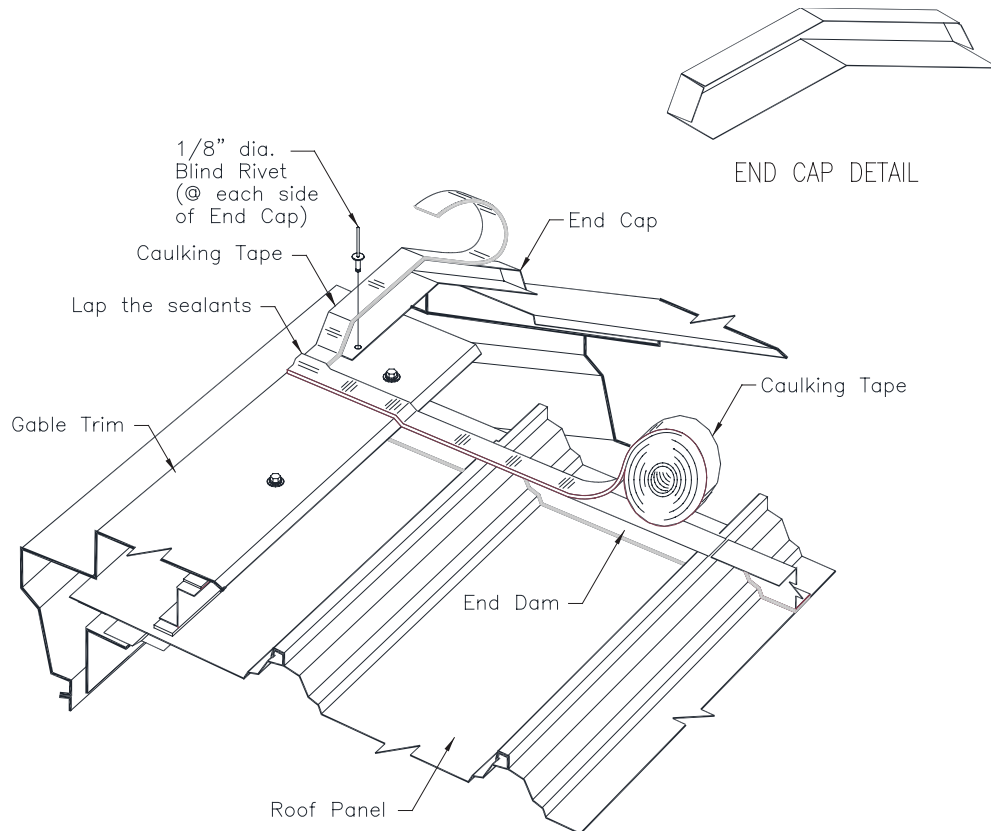

#### 9.10.2 INSTALL END CAP AT GABLE TRIM

Position the end cap so its face is flush with the face of the gable trim.

Fasten the end cap to the gable trim with (2) rivets as shown.

Install flashing sealant on top of the end cap as shown. Align the edge of the sealant flush with face of the end cap and extend the sealant to align with the end dams.

Install flashing sealant continuous along the top flange of the end dams. Lap the end of the sealant over the end cap sealant.

## 9.0 ROOF INSTALLATION DETAILS

### 9.10 RIDGE COVER INSTALLATION

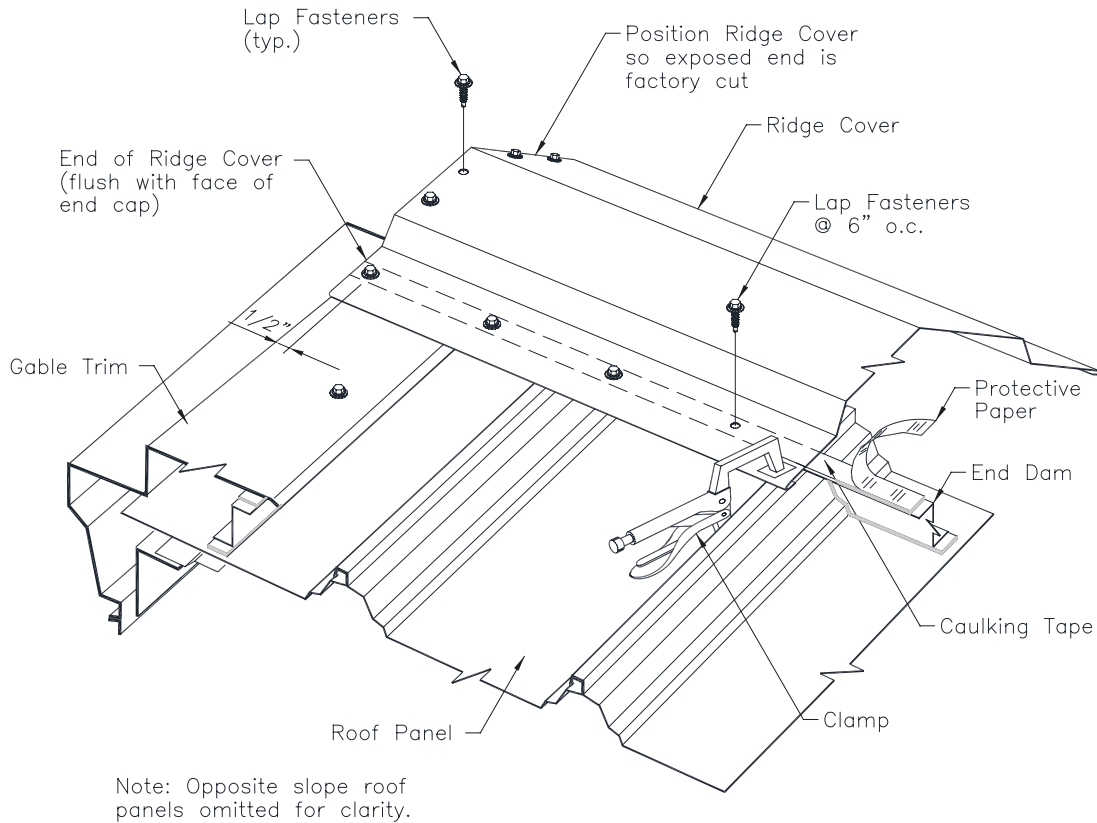

#### 9.10.3 INSTALL RIDGE COVER AT GABLE TRIM

Install the ridge cover to span across the opposing end dams run as shown.

Position the end of the ridge cover flush with the face of the end cap.

Align the center of the ridge cover over the ridge centerline. Use a string line to assure a straight ridge cover installation.

Fasten the ridge cover to the end dams with lap fasteners spaced as shown. Check that the fasteners penetrate the center of the caulking tape and securely engage the termination zee.

#### **IMPORTANT**

To provide watershed, the ridge cover must have a positive pitch, even during roof panel contraction.

To increase the ridge cover's pitch, first fasten only one edge of the ridge cover, then push on the opposite edge of the ridge cover to deflect its center upward. Hold it in this position with clamps while fastening the other edge.

## 9.0 ROOF INSTALLATION DETAILS

### 9.10 RIDGE COVER INSTALLATION

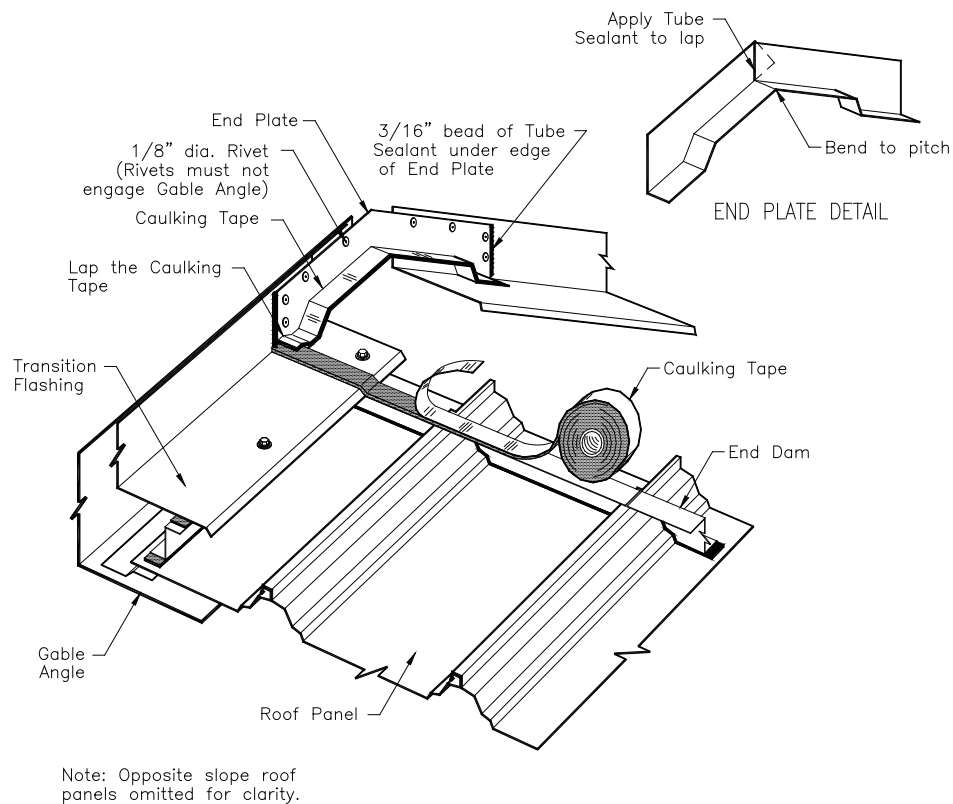

#### 9.10.4 INSTALL END CAP AT GABLE TRANSITION

Position the end plate so its face is flush with the face of the transition flashing.

Fasten the end plate to the transition flashing with rivets as shown.

Install caulking tape on top of the end plate as shown. Position the edge of the caulking flush against the face of the transition flashing and extend the ends of the caulking tape to align with the end dams.

Install caulking tape continuous along the top flange of the end dams.  
Lap the end of the caulking over the end cap.

## 9.0 ROOF INSTALLATION DETAILS

### 9.10 RIDGE COVER INSTALLATION

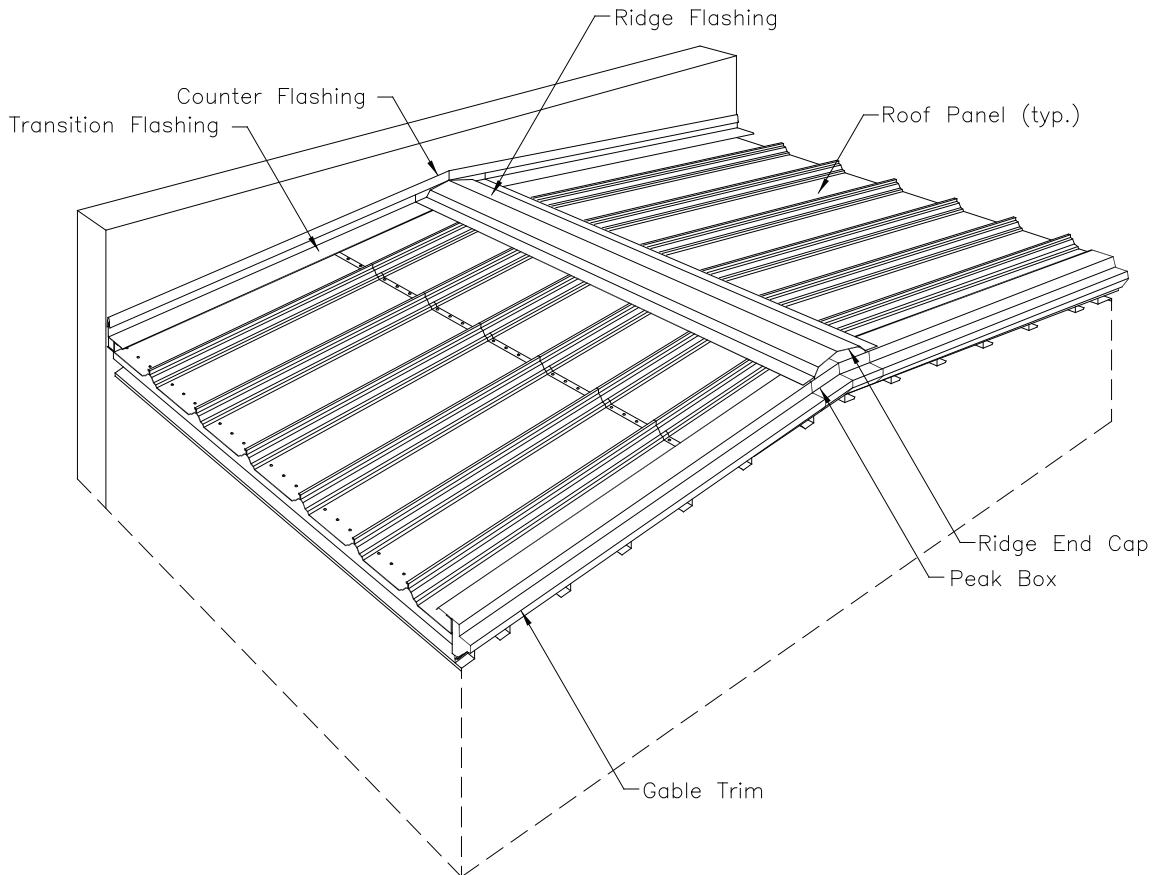

#### 9.10.5 INSTALL RIDGE COVER AT GABLE TRANSITION

Install the ridge cover to span across the opposing end dam runs as shown.

Position the end of the ridge cover flush against the face of the transition flashing.

Align the center of the ridge cover over the ridge centerline. Use a string line to assure a straight ridge cover installation.

Fasten the ridge cover to the end dams with lap fasteners spaced as shown. Check that the fasteners penetrate the center of the caulking tape and securely engage the termination zee.

#### **IMPORTANT**

To provide watershed, the ridge cover must have a positive pitch, even during roof panel contraction.

To increase the ridge cover's pitch, first fasten only one edge of the ridge cover, then push on the opposite edge of the ridge cover to deflect its center upward. Hold it in this position with clamps while fastening the other edge.

## 9.0 ROOF INSTALLATION DETAILS

### 9.10 RIDGE COVER INSTALLATION

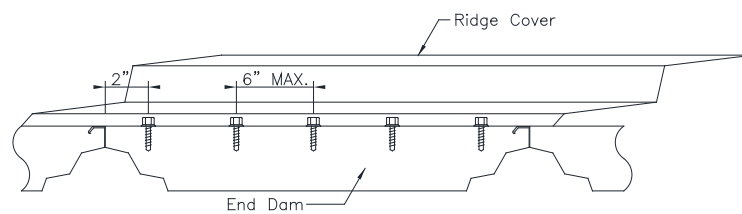
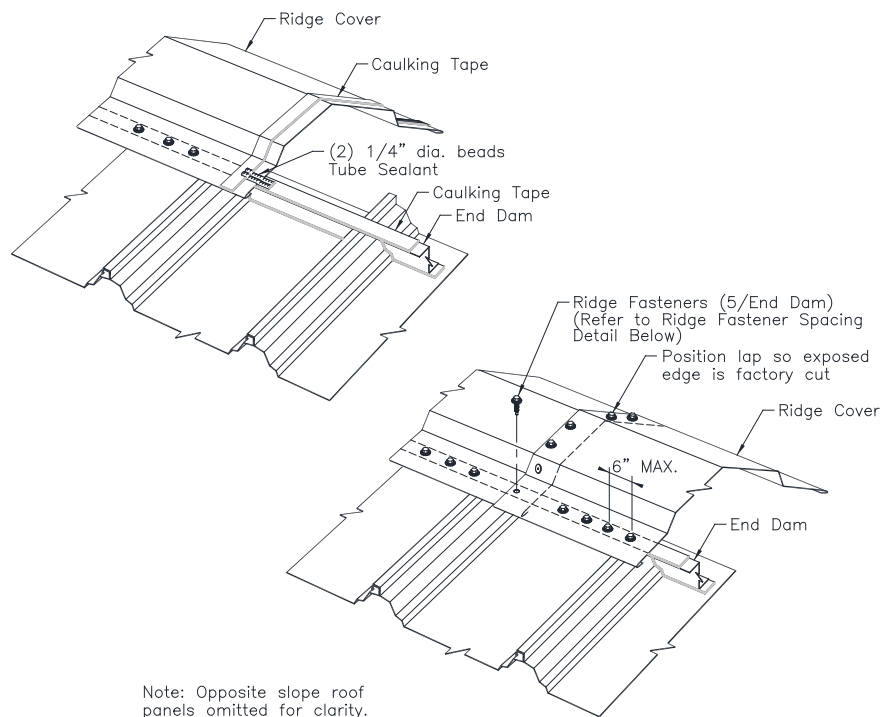

#### 9.10.6 RIDGE COVER ASSEMBLY AT SPLICE

Assemble the ridge cover splices with caulking tape and lap fasteners, as shown.

#### **IMPORTANT**

The splice fasteners must be installed carefully to avoid downward deflection and buckling of the ridge cover ends.

## 9.0 ROOF INSTALLATION DETAILS

### 9.11 HIGH EAVE TRANSITION INSTALLATION

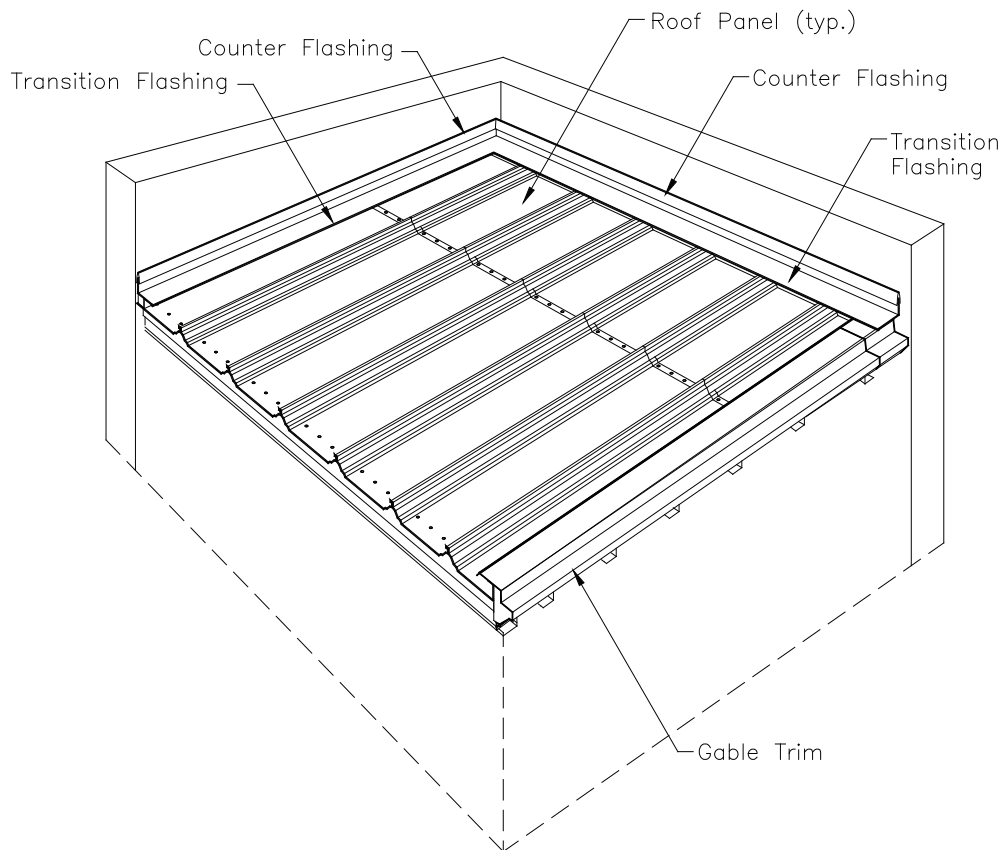

#### 9.11.1 ORIENTATION VIEW

The details in this section show the installation of high eave transition flashing.

The transition flashing can start or finish at either a gable trim condition or a gable transition condition.

In all cases, verify that counter flashing will:

- Restrain the transition flashing during roof live loads and wind loads.
- Provide a weather resistant seal between the transition flashing and the wall.

## 9.0 ROOF INSTALLATION DETAILS

### 9.11 HIGH EAVE TRANSITION INSTALLATION

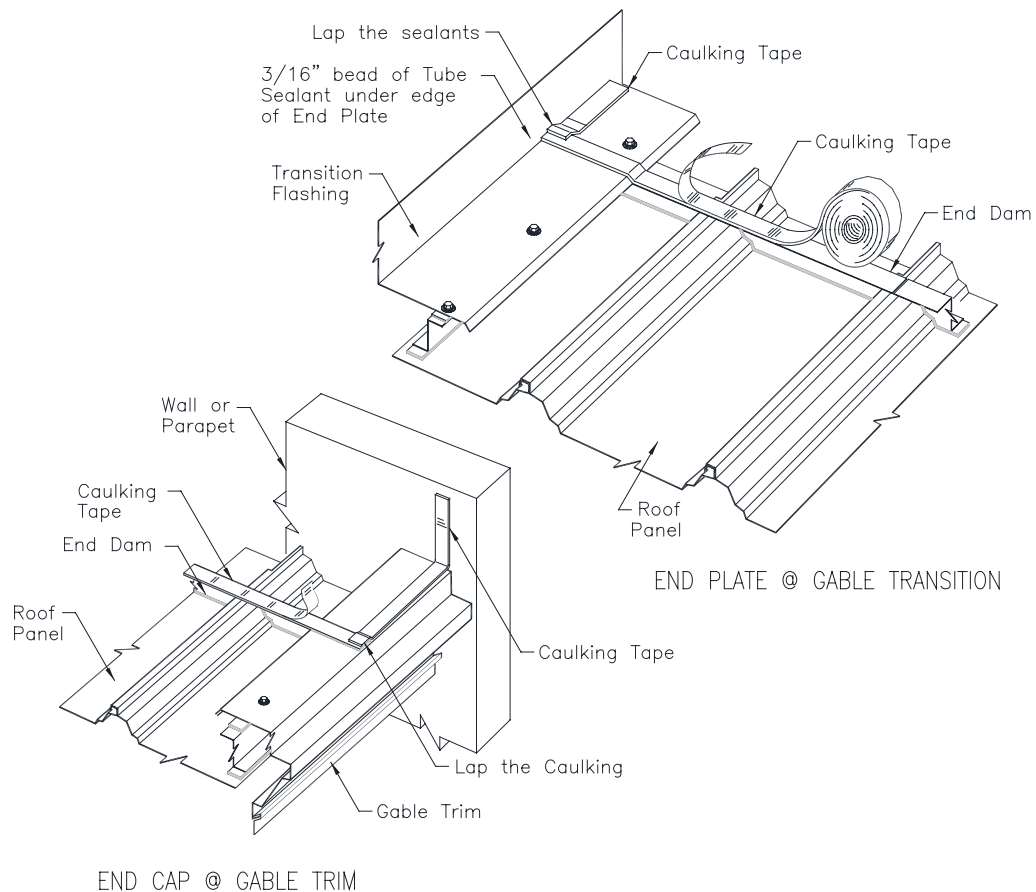

#### 9.11.2 INSTALL END CAP OR END PLATE AT GABLE TRIM OR GABLE TRANSITION

Field cut the end cap or end plate to fit as shown.

Position the end plate so its face is flush with the face of the gable trim or transition flashing.

Fasten the end cap or end plate with rivets as shown.

Install flashing sealant on top of the end cap or end plate as shown. Align the edge of the caulking flush with face of the end cap or transition flashing and extend the caulking to align with the end dams.

Install caulking tape continuous along the top flange of the end dams. Lap the end of the caulking over the end cap caulking.

## 9.0 ROOF INSTALLATION DETAILS

### 9.11 HIGH EAVE TRANSITION INSTALLATION

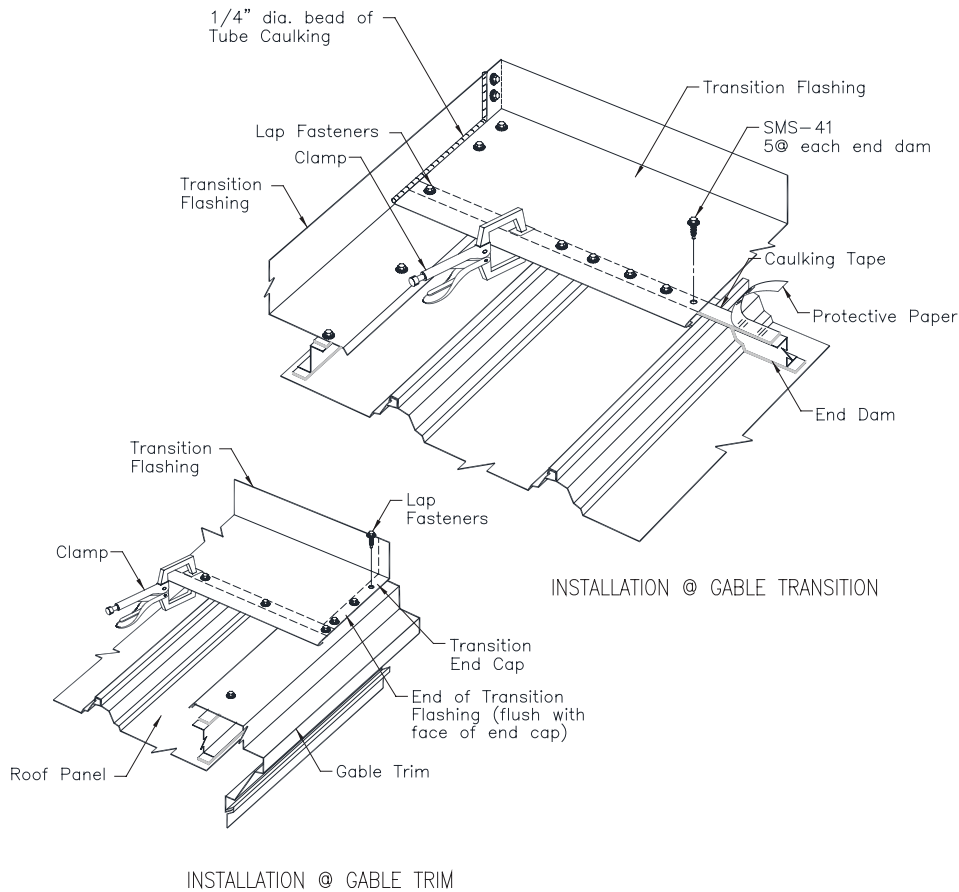

#### 9.11.3 INSTALL TRANSITION FLASHING AT GABLE TRIM OR GABLE TRANSITION

Install the transition flashing to span across the opposing end dams runs, as shown.

Position the end of the flashing flush with the face of the end cap or gable transition flashing and position the back leg flush with the wall construction.

Check that the flashing is set at a positive pitch to assure watershed.

Fasten the transition flashing to the end dams with lap fasteners spaced as shown. Check that the fasteners penetrate the center of the sealant and securely engage the termination zee.

## 9.0 ROOF INSTALLATION DETAILS

### 9.11 HIGH EAVE TRANSITION INSTALLATION

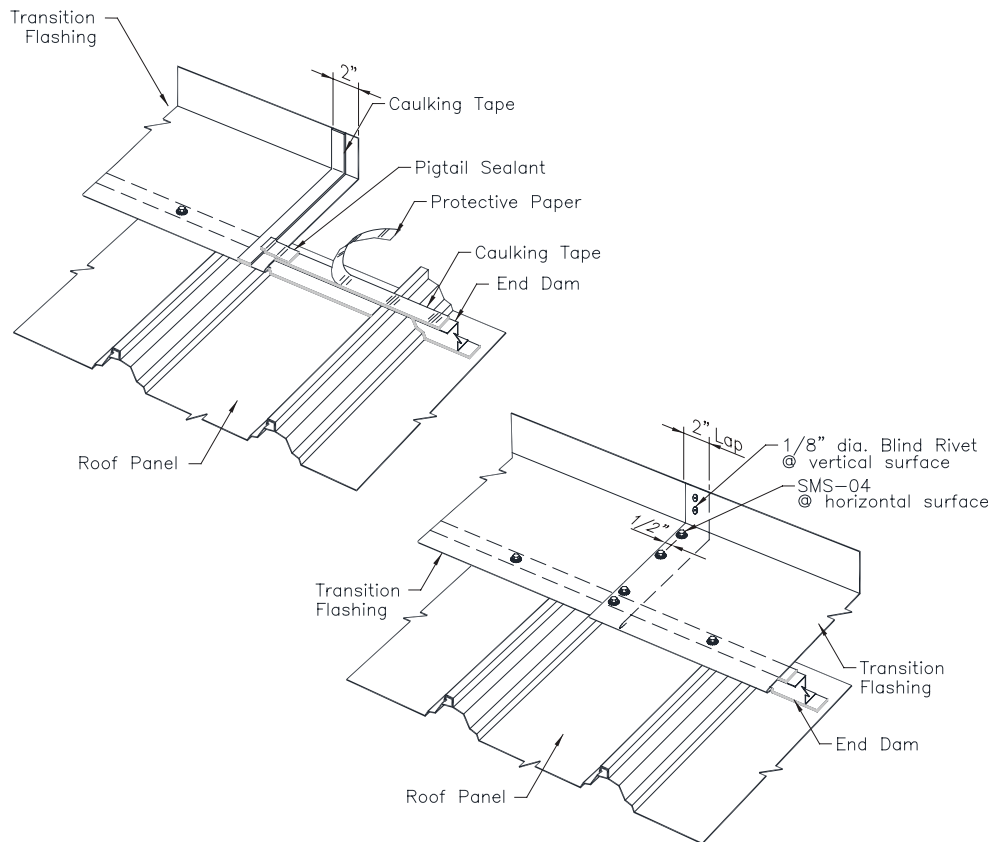

#### 9.11.4 TRANSITION FLASHING ASSEMBLY AT SPLICES

Assemble the transition flashing splices with flashing sealant and lap fasteners, as shown.

#### **IMPORTANT**

The splice fasteners must be installed carefully to avoid downward deflection and buckling of the flashing ends.

## 9.0 ROOF INSTALLATION DETAILS

### 9.12 EAVE GUTTER INSTALLATION

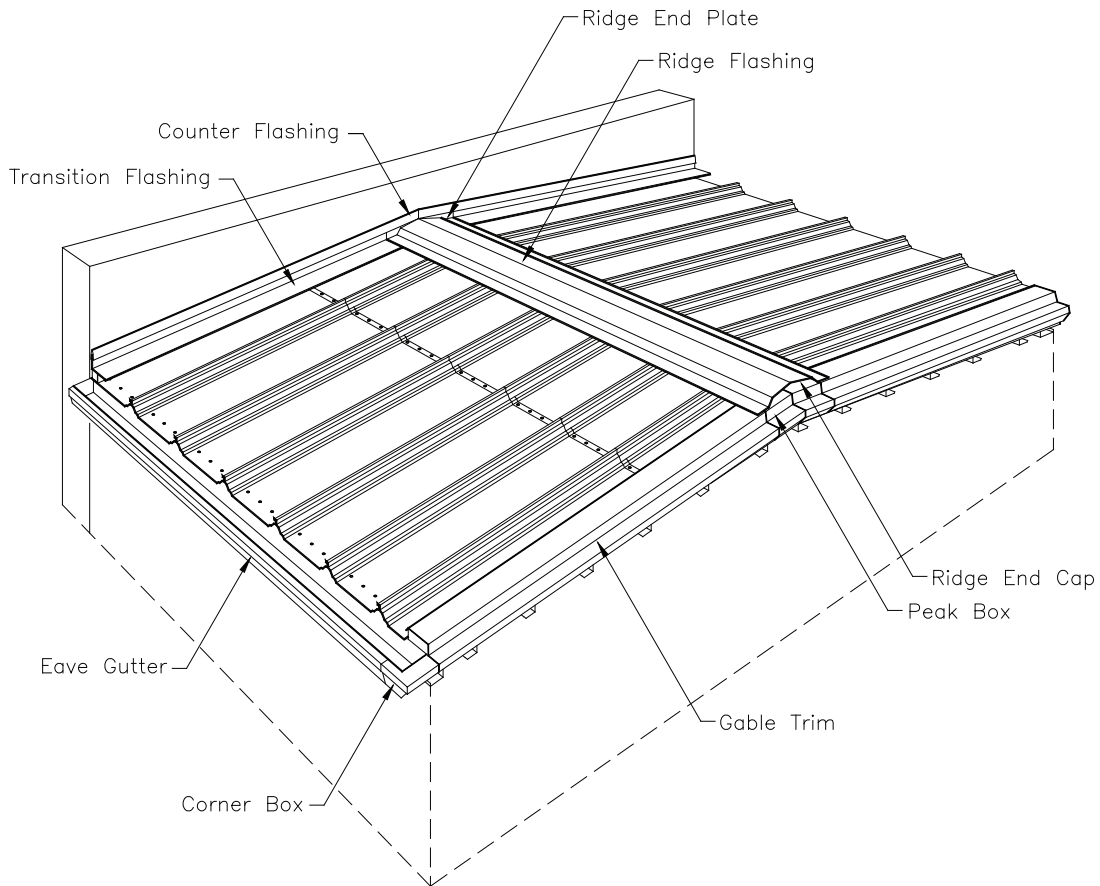

#### 9.12.1 ORIENTATION VIEW

The details in this section show assembly and installation of eave gutter.

Assembly of the gutter should be accomplished with care given to the final appearance. The appearance of the gutter will have a critical effect on the appearance of the project.

Determine which direction the building is most often viewed from. Install gutter laps facing away from the most often viewed direction.

Proper downspouts are necessary to prevent gutter overflow and roof flooding. Refer to the erection drawings to determine the required downspout size and spacing.

## 9.0 ROOF INSTALLATION DETAILS

### 9.12 EAVE GUTTER INSTALLATION

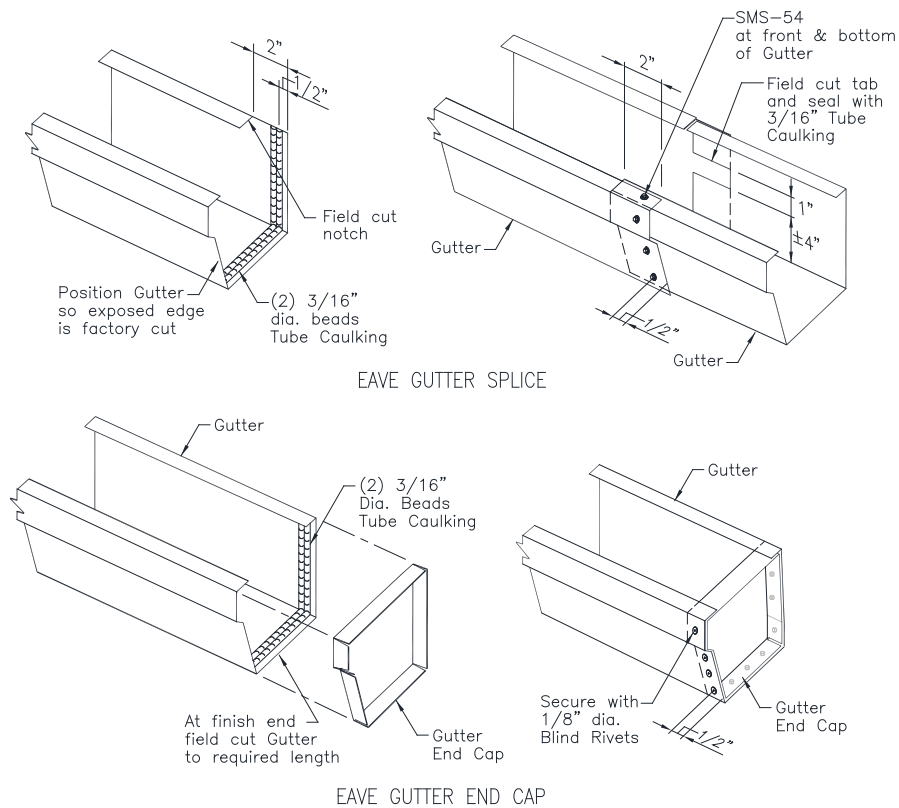

#### 9.12.2 ASSEMBLE EAVE GUTTER

Layout the gutter assemblies before installation on the roof.

Start and finish the gutter ends flush with the exterior face of the gable walls.

Assemble the gutter end caps and splices with tube caulking and rivets as shown on the above details.

## 9.0 ROOF INSTALLATION DETAILS

### 9.12 EAVE GUTTER INSTALLATION

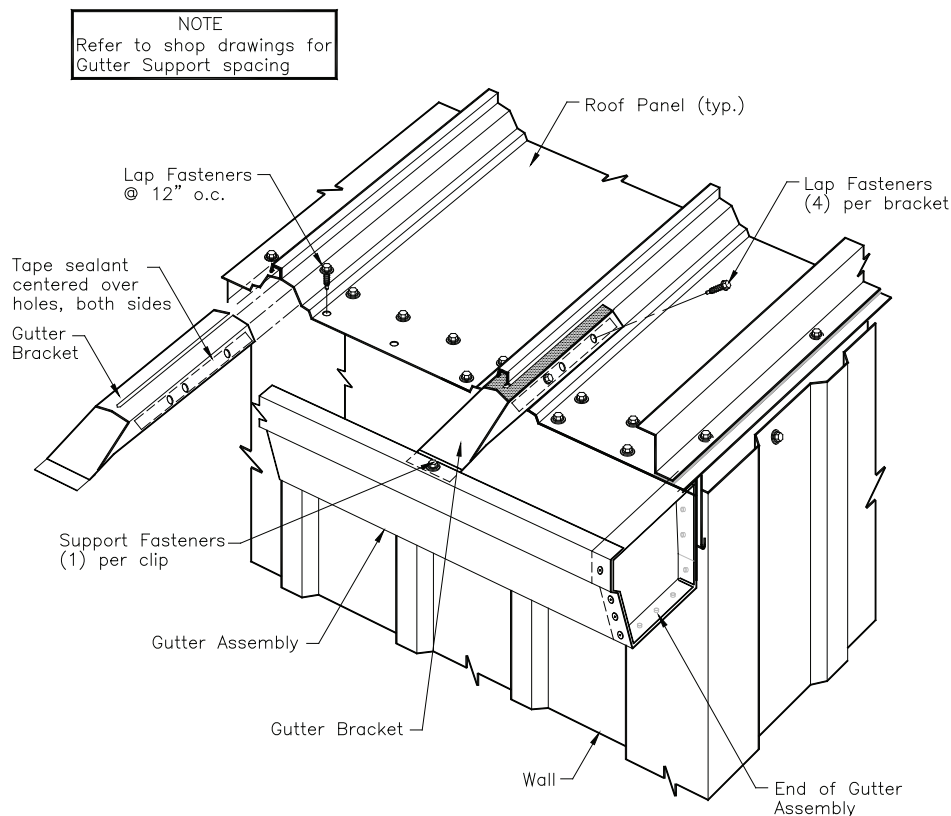

#### 9.12.3 INSTALL EAVE GUTTER

Lift the gutter assembly into position under the edge of the roof panels and temporarily clamp the back flange of the gutter to the roof panel.

Position the back face of the gutter assembly flush against the eave trim and position its ends flush with the exterior face of the gable wall.

Fasten the gutter's back flange to the underside of the roof panel with lap fasteners as shown.

Check that the lap fasteners are securely engaged into the gutter's back flange.

Apply strips of flashing sealant to the inside surface of the gutter bracket. Position the sealant over the factory punched holes in the support.

Align the outer edge of the gutter straight and level. Use a string line to assure that the gutter is straight.

Install the gutter bracket and fasten to the roof panel with lap fasteners. Refer to erection drawings for the required gutter support spacing.

Fasten the gutter's outer flange to the end of the gutter bracket as shown.

## 9.0 ROOF INSTALLATION DETAILS

### 9.12 EAVE GUTTER INSTALLATION

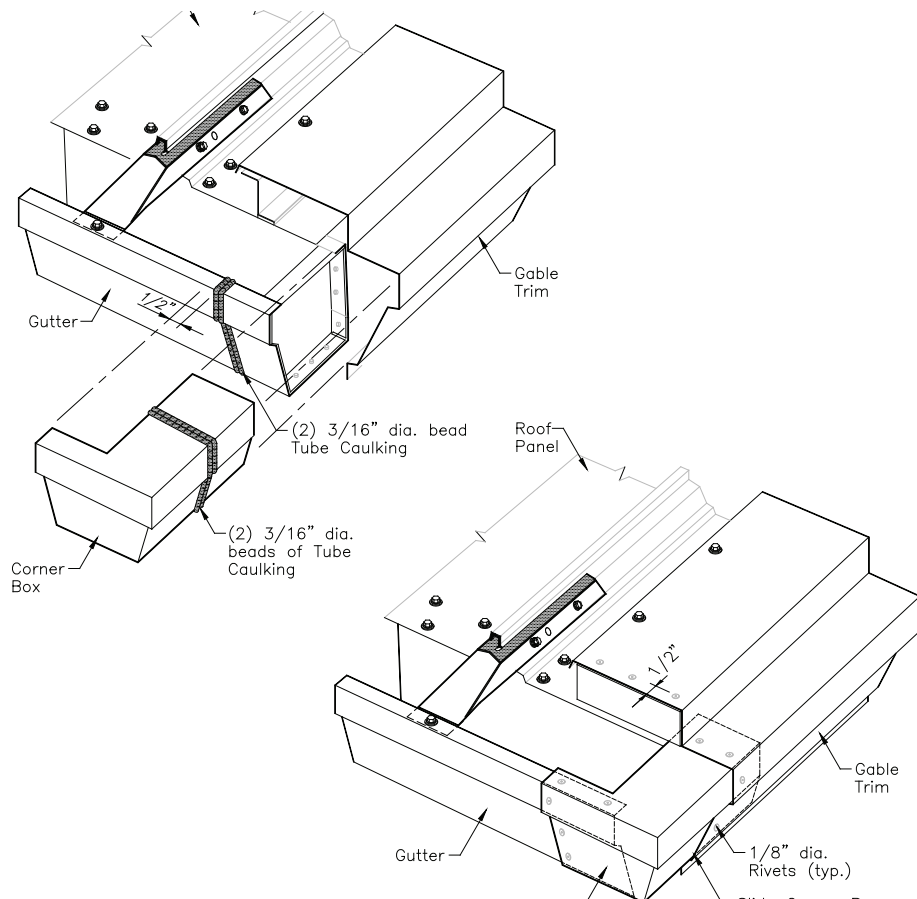

#### 9.12.4 INSTALL CORNER BOX

Install the corner boxes as shown.

Position the corner box to lap over the face of the gutter and inside of the gable trim.

Carefully align the corner box so it is straight and level with the gutter and the gable trim.

Attach the corner box with tube sealant and rivets as shown.

## 9.0 ROOF INSTALLATION DETAILS

### 9.13 HIP AND VALLEY INSTALLATION

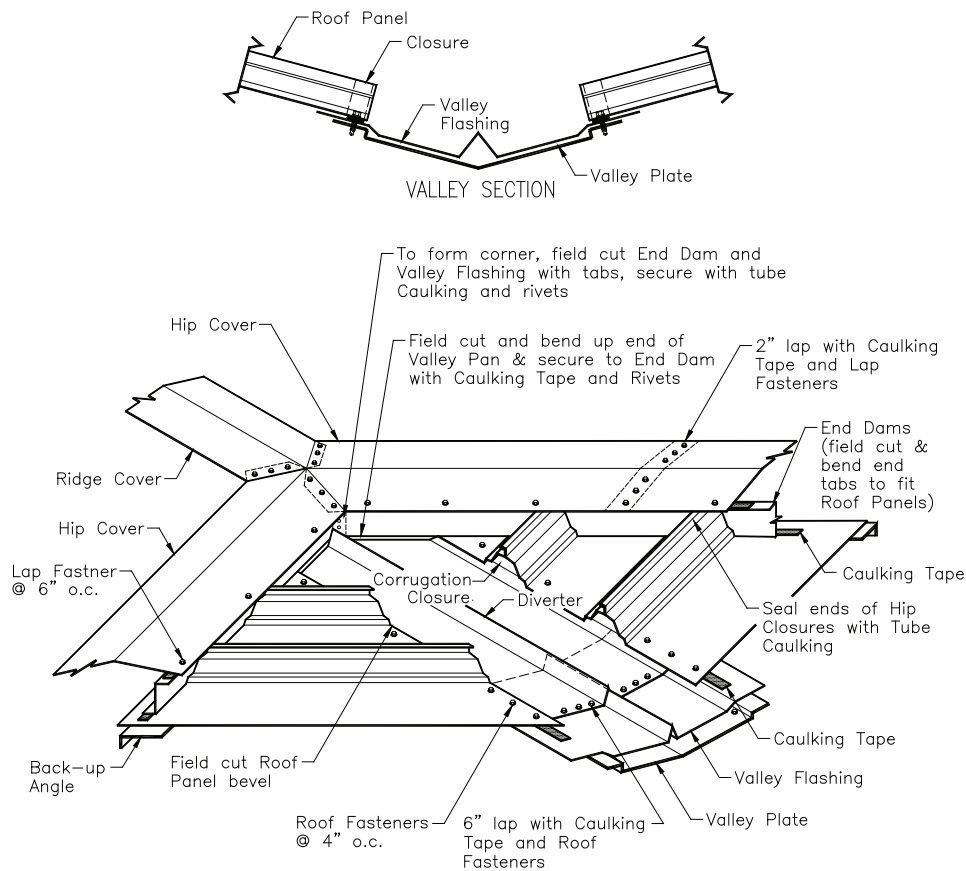

#### 9.13.1 HIP AND VALLEY DETAILS

The above details show typical hip and valley details. Refer to the erection drawings for specific hip and valley details.

Hip conditions are similar to ridge conditions, except special end dams and back-up angles are required to accommodate the beveled roof panel ends.

Valley conditions require beveled corrugation closures to accommodate the beveled roof panel ends.

**BLANK**

Any person installing or seaming a Steelway RTL-24 Standing Seam Roof System must read and understand this document before any work is started. Failure to do so will cause severe damage to the roof system and will void all product and performance warranties.

