

Energy Code Requirements: Canada

Introduction

The information contained in this document was provided by an independent third-party thermal analysis specialist (Morrison Hershfield) who is an industry leader in building thermal modeling.

Building energy requirements for commercial and mid- and high-rise construction in most jurisdictions across Canada reference energy efficiency standards and model codes from national and international organizations. The most commonly referenced building energy codes and standards in Canada are:

- **National Energy Code for Buildings (NECB)**
- **ASHRAE 90.1 “Energy Standard for Buildings Except Low-Rise Residential Buildings”**

Jurisdictions within Canada may also make modifications to these model energy codes and standards, such as Ontario, British Columbia, and Quebec. As such, the focus of this report is on the energy requirements for the majority of metal building construction in Canada and the energy requirements for the following Canadian codes and standards:

- **National Energy Code for Buildings (NECB) 2017**
- **Ontario Building Code Supplementary Standard SB-10 (OBC SB-10) 2016**

The OBC SB-10 2016 provides additional requirements to both NECB-2015 and ASHRAE 90.1-2013.

While these codes and standards differ in their specific requirements, they all provide three options for demonstrating compliance: Prescriptive, Trade-off, and Performance. A brief overview of these compliance paths regarding the thermal performance of the building envelope is given below. Designers should always check with the applicable codes and standards for energy compliance requirements for their projects.

Steelway Building Systems offers roof and wall assemblies that can be used as part of the solution required to determine over-all building compliance to the energy codes. It should be noted that the Owner/Builder/Coordinating Registered Professional that applies for the building permit is responsible for ensuring over-all building compliance to the applicable energy codes. The thermal assemblies that follow only form part of this compliance. Other factors like HVAC efficiency, lighting, building orientation, window/door thermal efficiency and wall assemblies not provided by Steelway can affect the final compliance level achieved. This assessment must be done by a professional knowledgeable in the field of Building Energy Science and is not the responsibility of Steelway Building Systems.

Compliance Paths

The **prescriptive path** awards compliance to the proposed building for explicitly meeting all provisions of the code or standard relevant to the project in question. For the building envelope, the thermal transmittance of the proposed assemblies, such as walls, roofs, and floors, must be lower than the prescribed maximum thermal transmittance U-value or must meet or exceed insulation values in a prescribed assembly. These requirements can be based on climate region, building assembly (e.g. walls, roofs etc.), and for some cases building type/principal heating source and framing type, depending on the code or standard. The prescriptive path is fairly straightforward. However, some prescriptive requirements may be difficult to achieve due to design trends. For example, both the NECB 2017 and ASHRAE 90.1-2016, sets the prescriptive requirement for the window to wall ratio (fenestration area to wall area) to less than 40%. Some prescriptive requirements may also be prohibitive to achieve when assemblies are selected upon other factors such as durability, service life, fire safety, or building occupancy. If the proposed building envelope assemblies cannot meet the prescriptive requirements, then another compliance path must be used.

Energy Code Requirements: Canada

The **trade-off path** awards compliance to the proposed building when the overall building envelope thermal transmittance is equal to or below the thermal transmittance of a reference building based on prescriptive U-values. This allows for some flexibility with the prescriptive values, as this method permits trade-off between the thermal performance of building envelope assemblies (i.e. roofs, walls, and fenestration) when the prescriptive requirements are not met by all building assemblies. With this approach, the improved thermal performance of one assembly (or assemblies) must offset the reduced thermal performance of another assembly (or assemblies). For example, this allows for buildings with multiple wall types to have a combination of assemblies that are lower and higher than prescribed thermal performance if they compensate for each other overall. Note, for some standards such as ASHRAE 90.1, different components such as roofs and walls may be traded, while some codes such as NECB-2017 do not allow vertical assemblies to be traded against horizontal assemblies. Under this path, trade-off between building envelope assemblies and other assemblies and components under other parts of the code (e.g. power, lighting etc.) cannot be made. Compliance can be demonstrated using either specific calculations (provided in the standards) or through computer software deemed to be compliant with the requirements of the standard or code.

The **performance path** compares the annual energy use of the entire proposed building to that of an equivalent reference building which meets the minimum prescribed requirements for all assemblies and systems individually, using computer simulation. Compliance is awarded when the simulated annual energy use of the proposed design is less than or equal to that of the simulated reference building. The reference building mostly retains the same shape, size, occupancy and scheduling of the proposed building, but depends on the applicable code or standard. For example, reference building models under ASHRAE 90.1- 2016 and NECB-2017 may not have the same fenestration areas for the same proposed building design. Each code and standard have requirements that specify what can and cannot be included in the energy model and which energy modelling programs can be used. This method evaluates all building energy use beyond the building envelope by taking into account other variables such as building orientation, HVAC systems efficiencies, and lighting controls, which are not considered with the other two compliance paths. Compliance building modelling is also popular amongst many building energy standards and energy certification programs such as Leadership in Energy and Environmental Design (LEED).

Recently, many high-performance building standards in Canada have developed requirements based on meeting absolute energy targets to be determined using computer simulations. Building energy standards and codes such as Passive House, the BC Energy Step Code, and the City of Toronto's Zero Emissions Framework, set absolute targets for Thermal Energy Demand Intensity (TEDI), which is the total annual heating energy required for the building per interior floor area, the Energy Use Intensity (EUI), which is the total annual energy consumption of the building per interior floor area, and perhaps greenhouse gasses (GHGs). Many of these standards have set modelling guidelines to determine the energy performance of the proposed building, which may include accounting for the effect of thermal bridging. Note some local jurisdictions, such as municipalities, may have supplementary requirements that designers need to follow including compliance with other programs, such as LEED or the BC Energy Step Code. **Always consult the local codes or with the local authority having jurisdiction for project specific requirements.**

Notes on SB-10 and Use of Tables

SB-10-2016 allows a project team to choose between the NECB-2015 or the ASHRAE 90.1-2013 pathway. However, once a path is chosen, it applies to the entire project, so the mechanical, and electrical designers also need to be aware which path is chosen.

Designers will tend to assume that the ASHRAE path will be followed just based on historical precedent as well as ASHRAE's less stringent envelope requirements. However, for mechanical and electrical designers, especially for a project using prescriptive compliance instead of performance compliance (energy modelling), the choice between ASHRAE or NECB is relatively inconsequential. The decision can be made due to the envelope requirement difference between the two codes. Communication needs to be clear with the whole design team as to which path to document.

Steelway Wall and Roof Assemblies and Prescriptive Energy Performance Requirements for Steel Building Systems in Canada

The below tables summarize the prescriptive wall and roof assembly thermal performance requirements for different climate zones in NECB-2017 and in OBC SB-10-2016. Note that while the NECB provides prescriptive energy performance requirements for building envelope components only in terms of maximum allowable wall assembly U-values, some standards allow compliance based on a minimum rated R-value of continuous insulation. For the sake of comparison, only maximum allowable assembly U-values are given in the tables.

NECB-2017 & OBC SB-10-2016 Effective U values (si) (National)
Overall Thermal Transmittance of Above-ground Opaque Building Assemblies

Above-ground Opaque Building Assembly	Heating Degree-Days of Building Location in Celsius Degree-Days					
	Zone 4 < 3000	Zone 5 3000 to 3999	Zone 6 4000 to 4999	Zone 7A 5000 to 5999	Zone 7B 6000 to 6999	Zone 8 ≥ 7000
	Maximum Overall Thermal Transmittance U _{si} in W/(m ² *K)					
Walls	0.315	0.278	0.247	0.210	0.210	0.183
Roofs	0.193	0.156	0.156	0.138	0.138	0.121

ASHRAE 90.1-2013 Effective U values (si) (National)
Overall Thermal Transmittance of Above-ground Opaque Building Assemblies

Above-ground Opaque Building Assembly	Heating Degree-Days of Building Location in Celsius Degree-Days				
	Zone 4A, 4B, 4C ≤ 3000	Zone 5A, 5B, 5C 3001 ≤ 4000	Zone 6A, 6B 4001 ≤ 5000	Zone 7 5001 ≤ 7000	Zone 8 ≥ 7001
	Maximum Overall Thermal Transmittance U _{si} in W/(m ² *K)				
Walls	0.341	0.256	0.250	0.225	0.220
Roofs	0.210	0.189	0.158	0.148	0.147

Conversions

1/U = R (R or RSI); R = 0.176 RSI; RSI = 5.68 R

Energy Code Requirements: Canada

The following tables lists the U-values of the evaluated metal building wall and roof assemblies and the highest applicable climate zones. It should be noted that although the Prescriptive Path method may be the easiest and most straight forward method for achieving envelope compliance, other methods such as the simple trade-off method or using free software such as COMcheck (accepted method for building compliance in Ontario) will provide better results and less envelope insulation in many cases.

When using COMcheck, select “Other (U-Factor option)” and either “Metal Building Roof” or “Metal Building Wall”. Then simply pick one of Steelway’s thermal assemblies and enter the applicable Effective U-value listed in our tables. Note, COMcheck uses Imperial units so enter U-values shown in brackets [BTU/(hr•FT²•°F)].

Thermal conductivity, also known as Lambda (denoted by the greek symbol λ), is the measure of how easily heat flows through a specific type of material, independent of the thickness of the material in question. It is measured in Watts per Metre Kelvin (W/mK).

Results are simulated for standard Batt insulation with a maximum thermal conductivity as qualified. Thermal conductivity of Batt insulation may vary from suppliers whereas the lower the thermal conductivity of a material, the better the thermal performance (i.e. the slower heat will move across a material). Therefore any product with a lower thermal conductivity than the qualified maximum thermal conductivity will perform better than the published values.

Thermal StormSeal Roof System: Standard

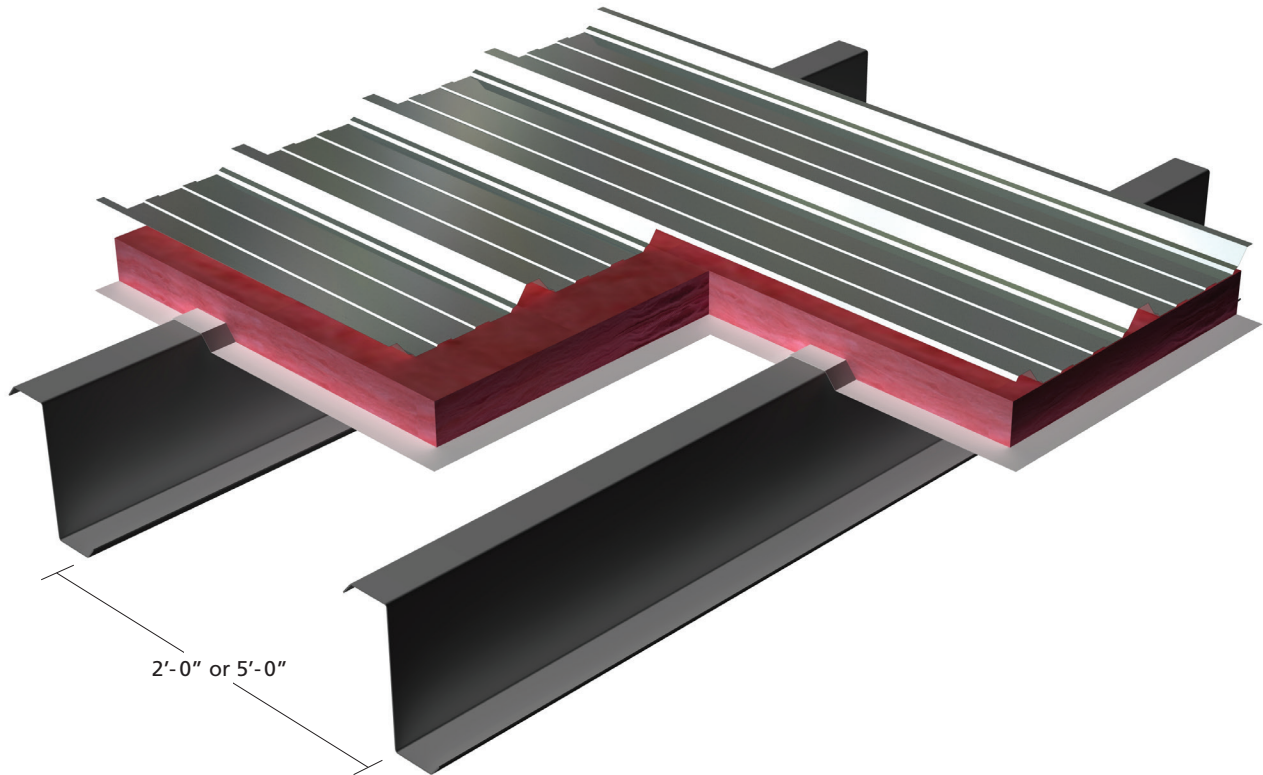

StormSeal roof, faced insulation draped over purlins, purlin spacing as listed below

Purlin Spacing mm (ft)	Rated Value of Insulation (nominal)		Overall Insulation Thickness mm (in)	Effective Assembly U-Value W/(m ² K) (BTU/(hr•FT ² •°F))	Effective Assembly R-Value m ² K/W (hr•FT ² •°F/BTU)
	RSI	R			
1524 (5'-0")	3.52	20	152 (6)	0.312 (0.055)	3.2 (R-18.2)
610 (2'-0")	3.52	20	152 (6)	0.374 (0.066)	2.67 (R-15.2)

Notes:

- Standard Batt insulation with a maximum Thermal Conductivity of 0.042 W/(m•K) [0.29 BTU/(hr•FT²•°F)] per inch. Insulation not provided by Steelway Building Systems.
- Effective U values for purlin spacing between modeled values can be extrapolated
- 3D Thermal modeling conducted by Morrison Hershfield using steel building components manufactured by Steelway Building Systems. Software validated as part of ASHRAE Research Project 1365-RP.

Thermal Standing Seam Roof System: Standard

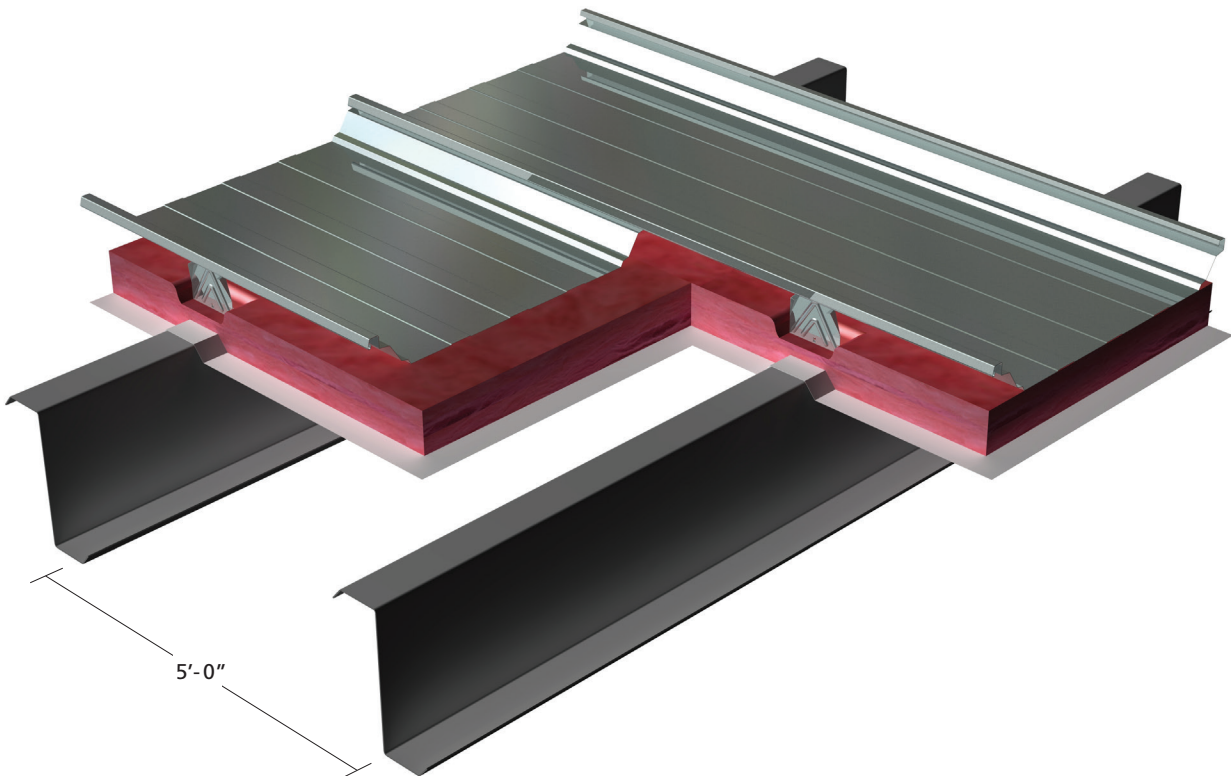

Purlins at 5'-0", RTL-24 roof, faced insulation draped over purlins

Rated Value of Insulation (nominal)		Overall Insulation Thickness mm (in)	Effective Assembly U-Value W/(m ² K) (BTU/(hr•FT ² •°F))	Effective Assembly R-Value m ² K/W (hr•FT ² •°F/BTU)
RSI	R			
3.52	20	152 (6)	0.357 (0.063)	2.80 (R-15.9)
5.46 (3.52 + 1.94)	31 (20 + 11)	229 (9)	0.289 (0.051)	3.46 (R-19.6)

Notes:

- Standard Batt insulation with a maximum Thermal Conductivity of 0.042 W/(m•K) [0.29 BTU/(hr•FT²•°F)] per inch. Insulation not provided by Steelway Building Systems.
- Thermal block to have a maximum Thermal Conductivity of 0.029 W/(m•K) [0.20 BTU/(hr•FT²•°F)] per inch.
- Minimum 1" (25mm) [R5 (RSI 0.88)] thermal block on top of purlins.
- 3D Thermal modeling conducted by Morrison Hershfield using steel building components manufactured by Steelway Building Systems. Software validated as part of ASHRAE Research Project 1365-RP.
- *RTL 6" High Clip used with Two (2) layers of Batt insulation: 6" Batt [R20 (RSI 3.52)] & 3" Batt [R11 (RSI 1.94)].

Energy Code Requirements: Canada

Thermal CapLoc Roof System: Standard Purlins at 6'-0"

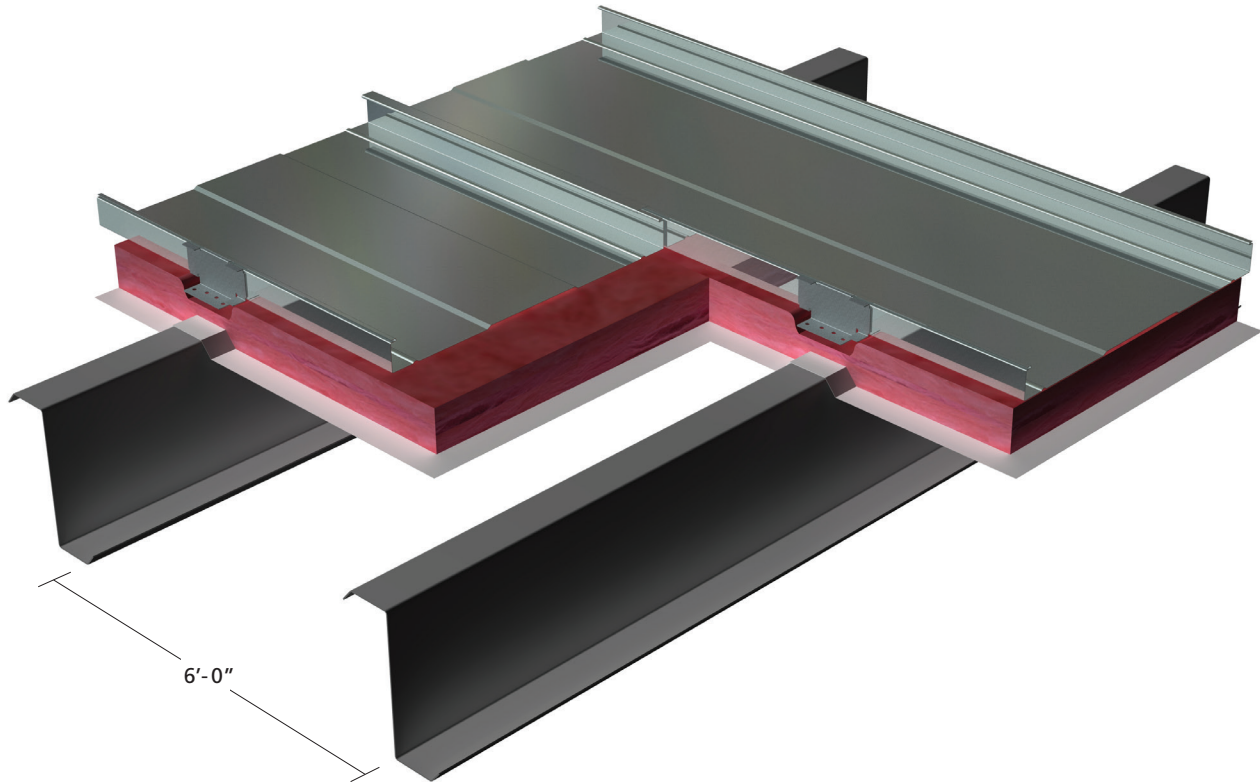

Purlins at 6'-0", CapLoc roof, faced insulation draped over purlins

Panel Rib Spacing mm (in)	Rated Value of Insulation (nominal)		Overall Insulation Thickness mm (in)	Effective Assembly U-Value W/(m ² K) (BTU/(hr•FT ² •°F))	Effective Assembly R-Value m ² K/W (hr•FT ² •°F/BTU)
	RSI	R			
405 (16)	3.52	20	152 (6)	0.309 (0.054)	3.23 (R-18.4)
457 (18)	3.52	20	152 (6)	0.307 (0.054)	3.26 (R-18.5)
610 (24)	3.52	20	152 (6)	0.289 (0.051)	3.46 (R-19.6)

Notes:

- Standard Batt insulation with a maximum Thermal Conductivity of 0.042 W/(m•K) [0.29 BTU/(hr•FT²•°F)] per inch. Insulation not provided by Steelway Building Systems.
- Thermal block to have a maximum Thermal Conductivity of 0.029 W/(m•K) [0.20 BTU/(hr•FT²•°F)] per inch.
- Minimum 1" (25mm) [R5 (RSI 0.88)] thermal block on top of purlins.
- 3D Thermal modeling conducted by Morrison Hershfield using steel building components manufactured by Steelway Building Systems. Software validated as part of ASHRAE Research Project 1365-RP.

Energy Code Requirements: Canada

Thermal CapLoc Roof System: Standard Purlins at 2'-0"

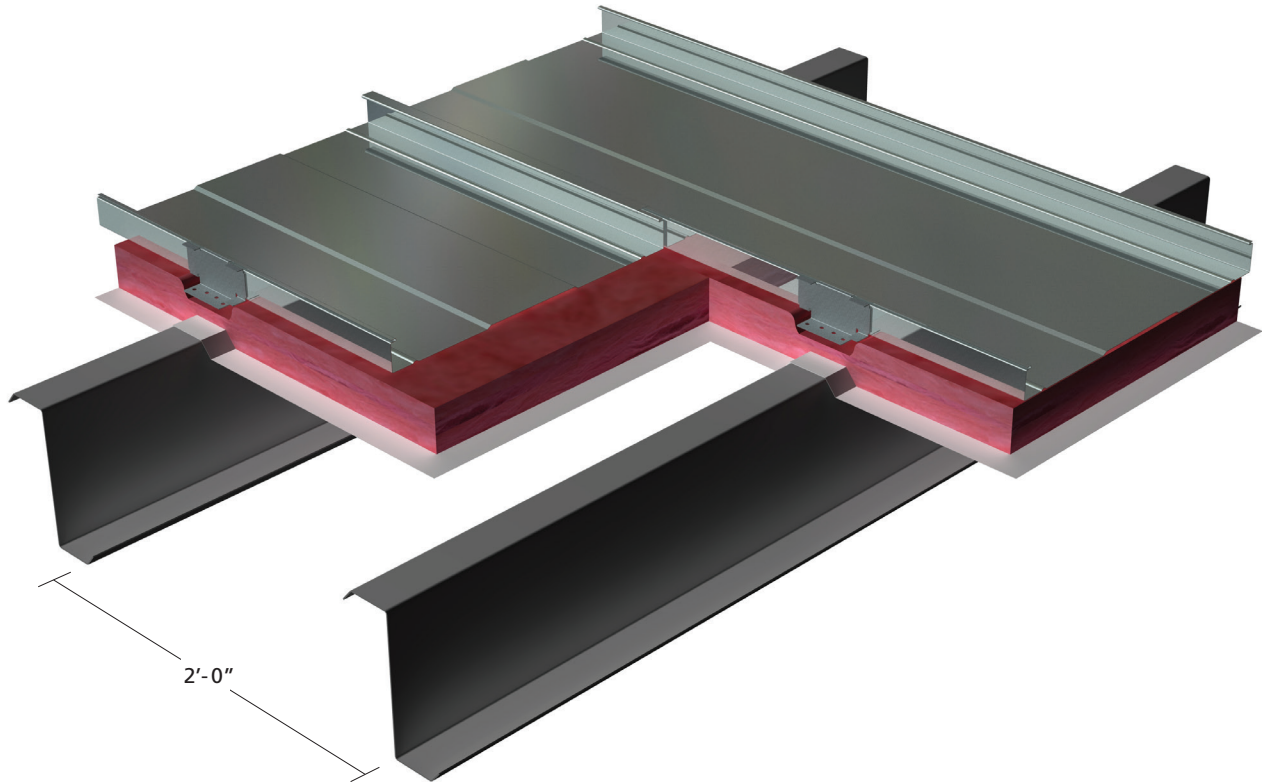

Purlins at 2'-0", CapLoc roof, faced insulation draped over purlins

Panel Rib Spacing mm (in)	Rated Value of Insulation (nominal)		Overall Insulation Thickness mm (in)	Effective Assembly U-Value W/(m ² K) (BTU/(hr•FT ² •°F))	Effective Assembly R-Value m ² K/W (hr•FT ² •°F/BTU)
	RSI	R			
405 (16)	3.52	20	152 (6)	0.383 (0.067)	2.61 (R-14.8)
457 (18)	3.52	20	152 (6)	0.364 (0.064)	2.74 (R-15.6)
610 (24)	3.52	20	152 (6)	0.322 (0.057)	3.11 (R-17.6)

Notes:

- Standard Batt insulation with a maximum Thermal Conductivity of 0.042 W/(m•K) [0.29 BTU/(hr•FT²•°F)] per inch. Insulation not provided by Steelway Building Systems.
- Thermal block to have a maximum Thermal Conductivity of 0.029 W/(m•K) [0.20 BTU/(hr•FT²•°F)] per inch.
- Minimum 1" (25mm) [R5 (RSI 0.88)] thermal block on top of purlins.
- 3D Thermal modeling conducted by Morrison Hershfield using steel building components manufactured by Steelway Building Systems. Software validated as part of ASHRAE Research Project 1365-RP.

Energy Code Requirements: Canada

Thermal Standing Seam Roof System: Hat and Chair Stand-off Purlins at 5'-0"

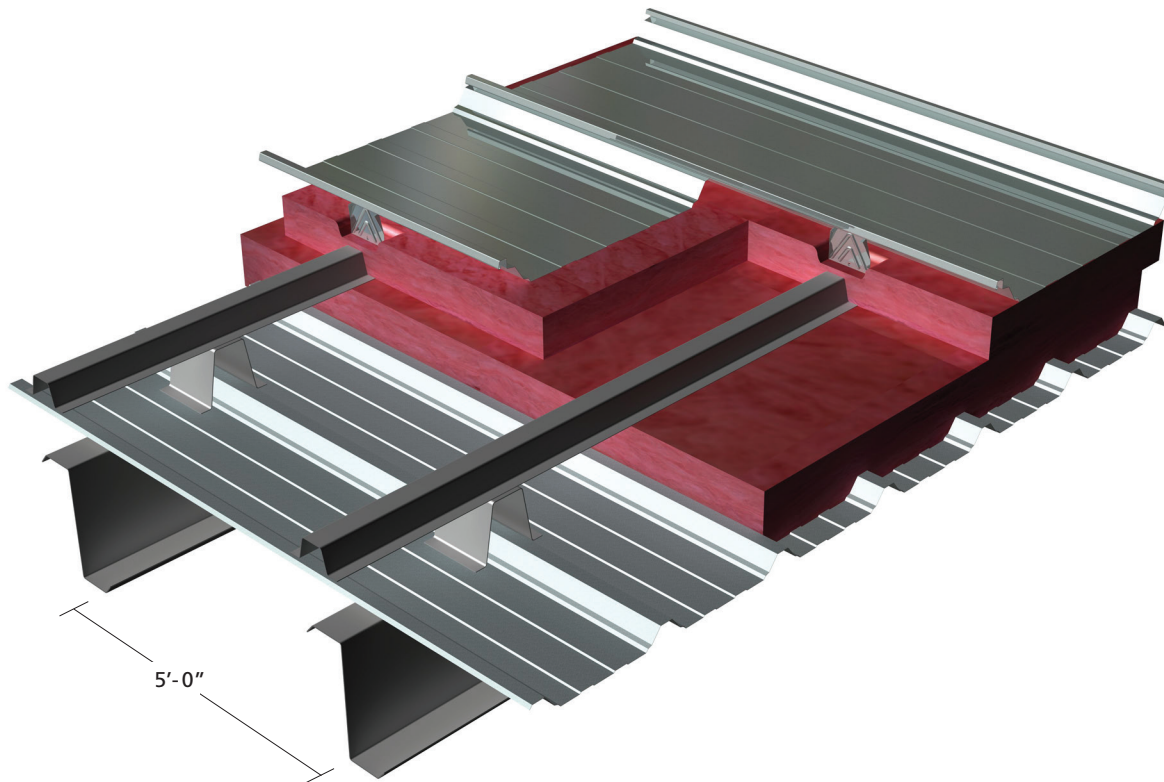

Purlins at 5'-0" with chairs spacing of 48" o/c, RTL-24 roof

Rated Value of Insulation (nominal)		Overall Insulation Thickness mm (in)	Chair Height mm (in)	Hat Height mm (in)	Effective Assembly U-Value W/(m ² K) (BTU/(hr•FT ² •°F))	Effective Assembly R-Value m ² K/W (hr•FT ² •°F/BTU)	Highest Zone Meet with NECB 2017 / OBC SB-10- 2016	Highest Zone Meet with ASHRAE 90.1-2013
RSI	R							
6.70 (4.23 + 2.47)	38 (24 + 14)	279 (11)	178 (7)	47.7 (1-7/8)	0.164 (0.029)	6.10 (R-34.6)	4	5A, 5B, 5C
7.23 (4.76 + 2.47)	41 (27 + 14)	305 (12)	203 (8)	47.7 (1-7/8)	0.151 (0.027)	6.61 (R-37.5)	6	6A, 6B
7.93 (5.46 + 2.47)	45 (31 + 14)	330 (13)	229 (9)	47.7 (1-7/8)	0.139 (0.024)	7.20 (R-40.9)	6	7
9.16 (6.69 + 2.47)	52 (38 + 14)	381 (15)	279 (11)	47.7 (1-7/8)	0.121 (0.021)	8.25 (R-46.8)	7A,7B	8
10.40 (7.93 + 2.47)	59 (45 + 14)	432 (17)	330 (13)	47.7 (1-7/8)	0.107 (0.019)	9.34 (R-53.0)	8	8

Notes:

- Standard Batt insulation with a maximum Thermal Conductivity of 0.042 W/(m•K) [0.29 BTU/(hr•FT²•°F)] per inch. Insulation not provided by Steelway Building Systems.
- Thermal block to have a maximum Thermal Conductivity of 0.029 W/(m•K) [0.20 BTU/(hr•FT²•°F)] per inch.
- Thermal tape to have a maximum Thermal Conductivity of 0.031 W/(m•K) [0.22 BTU/(hr•FT²•°F)] per inch.
- Standard 4" Batt insulation R14 (RSI 2.47) over the top of purlin sections.
- Minimum 1" (25mm) [R5 (RSI 0.88)] thermal block on top of purlins.
- Minimum 1/4" (6mm) [R1.15 (RSI 0.203)] thermal tape between chair and liner.
- Standard 1-7/8" hat section height.
- Effective U values for purlin spacing between modeled values can be extrapolated.
- 3D Thermal modeling conducted by Morrison Hershfield using steel building components manufactured by Steelway Building Systems. Software validated as part of ASHRAE Research Project 1365-RP.

Energy Code Requirements: Canada

Thermal Standing Seam Roof System: Hat and Chair Stand-off Purlins at 2'-0"

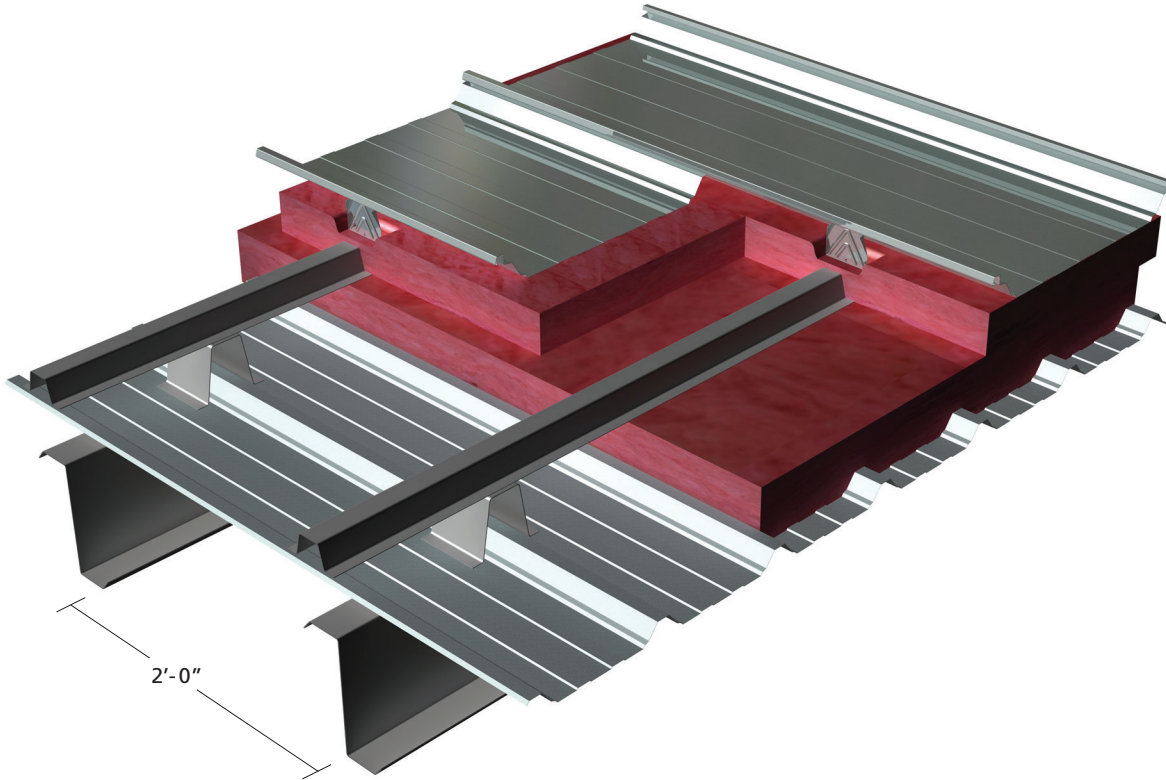

Purlins at 2'-0" with chairs spacing of 48" o/c, RTL-24 roof

Rated Value of Insulation (nominal)		Overall Insulation Thickness mm (in)	Chair Height mm (in)	Hat Height mm (in)	Effective Assembly U-Value W/(m ² K) (BTU/(hr•FT ² •°F))	Effective Assembly R-Value m ² K/W (hr•FT ² •°F/BTU)	Highest Zone Meet with NECB 2017 / OBC SB-10- 2016	Highest Zone Meet with ASHRAE 90.1-2013
RSI	R							
6.70 (4.23 + 2.47)	38 (24 + 14)	279 (11)	178 (7)	47.7 (1-7/8)	0.183 (0.032)	5.46 (R-31.0)	4	5A, 5B, 5C
7.23 (4.76 + 2.47)	41 (27 + 14)	305 (12)	203 (8)	47.7 (1-7/8)	0.171 (0.030)	5.86 (R-33.3)	4	5A, 5B, 5C
7.93 (5.46 + 2.47)	45 (31 + 14)	330 (13)	229 (9)	47.7 (1-7/8)	0.158 (0.028)	6.32 (R-35.9)	4	6A, 6B
9.16 (6.69 + 2.47)	52 (38 + 14)	381 (15)	279 (11)	47.7 (1-7/8)	0.141 (0.025)	7.11 (R-40.4)	6	7
10.40 (7.93 + 2.47)	59 (45 + 14)	432 (17)	330 (13)	47.7 (1-7/8)	0.127 (0.022)	7.90 (R-44.9)	7A,7B	8

Notes:

- Standard Batt insulation with a maximum Thermal Conductivity of 0.042 W/(m•K) [0.29 BTU/(hr•FT²•°F)] per inch. Insulation not provided by Steelway Building Systems.
- Thermal block to have a maximum Thermal Conductivity of 0.029 W/(m•K) [0.20 BTU/(hr•FT²•°F)] per inch.
- Thermal tape to have a maximum Thermal Conductivity of 0.031 W/(m•K) [0.22 BTU/(hr•FT²•°F)] per inch.
- Standard 4" Batt insulation R14 (RSI 2.47) over the top of purlin sections.
- Minimum 1" (25mm) [R5 (RSI 0.88)] thermal block on top of purlins.
- Minimum 1/4" (6mm) [R1.15 (RSI 0.203)] thermal tape between chair and liner.
- Standard 1-7/8" hat section height.
- Effective U values for purlin spacing between modeled values can be extrapolated.
- 3D Thermal modeling conducted by Morrison Hershfield using steel building components manufactured by Steelway Building Systems. Software validated as part of ASHRAE Research Project 1365-RP.

Energy Code Requirements: Canada

Thermal CapLoc Roof System: Hat and Chair Stand-off Purlins at 6'-0", Ribs at 16" o/c

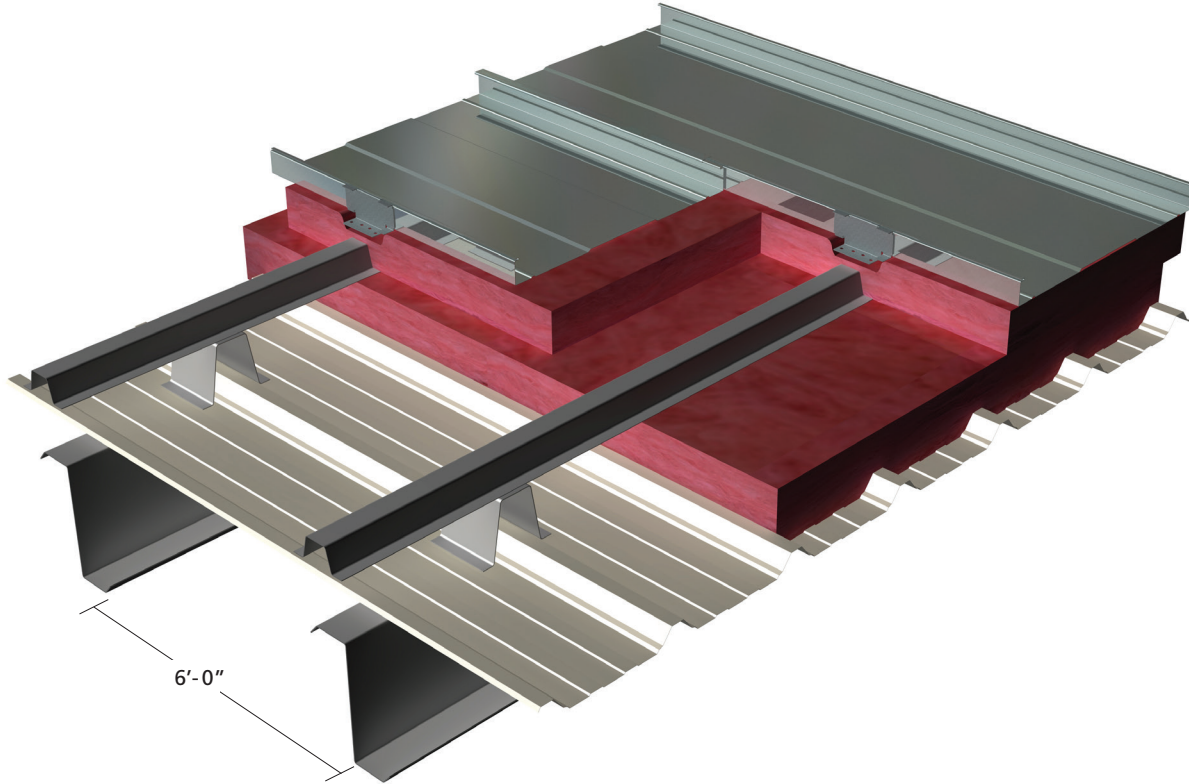

Purlins at 6'-0" with chairs spacing of 48" o/c, CapLoc roof (Ribs at 16" o/c)

Rated Value of Insulation (nominal)		Overall Insulation Thickness mm (in)	Chair Height mm (in)	Hat Height mm (in)	Effective Assembly U-Value W/(m ² K) (BTU/(hr•FT ² •°F))	Effective Assembly R-Value m ² K/W (hr•FT ² •°F/BTU)	Highest Zone Meet with NECB 2017 / OBC SB-10-2016	Highest Zone Meet with ASHRAE 90.1-2013
RSI	R							
6.70 (4.23 + 2.47)	38 (24 + 14)	279 (11)	178 (7)	47.7 (1-7/8)	0.163 (0.029)	6.14 (R-34.9)	4	5A, 5B, 5C
7.23 (4.76 + 2.47)	41 (27 + 14)	305 (12)	203 (8)	47.7 (1-7/8)	0.151 (0.027)	6.60 (R-37.5)	5	6A, 6B
7.93 (5.46 + 2.47)	45 (31 + 14)	330 (13)	229 (9)	47.7 (1-7/8)	0.139 (0.024)	7.21 (R-40.9)	6	8
9.16 (6.69 + 2.47)	52 (38 + 14)	381 (15)	279 (11)	47.7 (1-7/8)	0.121 (0.021)	8.27 (R-46.9)	8	8
10.40 (7.93 + 2.47)	59 (45 + 14)	432 (17)	330 (13)	47.7 (1-7/8)	0.107 (0.019)	9.31 (R-52.9)	8	8

Notes:

- Standard Batt insulation with a maximum Thermal Conductivity of 0.042 W/(m•K) [0.29 BTU/(hr•FT²•°F)] per inch. Insulation not provided by Steelway Building Systems.
- Thermal block to have a maximum Thermal Conductivity of 0.029 W/(m•K) [0.20 BTU/(hr•FT²•°F)] per inch.
- Thermal tape to have a maximum Thermal Conductivity of 0.031 W/(m•K) [0.22 BTU/(hr•FT²•°F)] per inch.
- Standard 4" Batt insulation R14 (RSI 2.47) over the top of purlin sections.
- Minimum 1" (25mm) [R5 (RSI 0.88)] thermal block on top of purlins.
- Minimum 1/4" (6mm) [R1.15 (RSI 0.203)] thermal tape between chair and liner.
- Standard 1-7/8" hat section height.
- Effective U values for purlin spacing between modeled values can be extrapolated.
- 3D Thermal modeling conducted by Morrison Hershfield using steel building components manufactured by Steelway Building Systems. Software validated as part of ASHRAE Research Project 1365-RP.

Energy Code Requirements: Canada

Thermal CapLoc Roof System: Hat and Chair Stand-off Purlins at 6'-0", Ribs at 18" o/c

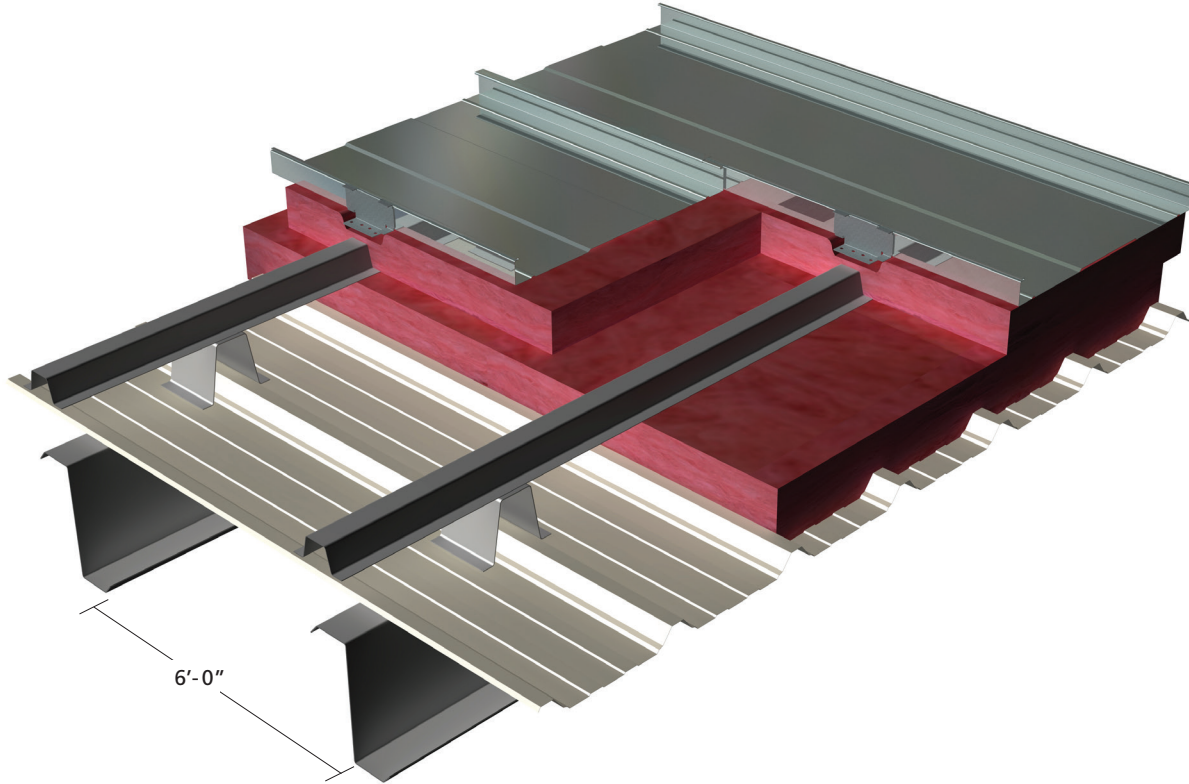

Purlins at 6'-0" with chairs spacing of 48" o/c, CapLoc roof (Ribs at 18" o/c)

Rated Value of Insulation (nominal)		Overall Insulation Thickness mm (in)	Chair Height mm (in)	Hat Height mm (in)	Effective Assembly U-Value W/(m ² K) (BTU/(hr•FT ² •°F))	Effective Assembly R-Value m ² K/W (hr•FT ² •°F/BTU)	Highest Zone Meet with NECB 2017 / OBC SB-10-2016	Highest Zone Meet with ASHRAE 90.1-2013
RSI	R							
6.70 (4.23 + 2.47)	38 (24 + 14)	279 (11)	178 (7)	47.7 (1-7/8)	0.163 (0.029)	6.13 (R-34.8)	4	5A, 5B, 5C
7.23 (4.76 + 2.47)	41 (27 + 14)	305 (12)	203 (8)	47.7 (1-7/8)	0.152 (0.027)	6.60 (R-37.5)	5	6A, 6B
7.93 (5.46 + 2.47)	45 (31 + 14)	330 (13)	229 (9)	47.7 (1-7/8)	0.139 (0.024)	7.20 (R-40.9)	6	8
9.16 (6.69 + 2.47)	52 (38 + 14)	381 (15)	279 (11)	47.7 (1-7/8)	0.121 (0.021)	8.26 (R-46.9)	8	8
10.40 (7.93 + 2.47)	59 (45 + 14)	432 (17)	330 (13)	47.7 (1-7/8)	0.107 (0.019)	9.32 (R-52.9)	8	8

Notes:

- Standard Batt insulation with a maximum Thermal Conductivity of 0.042 W/(m•K) [0.29 BTU/(hr•FT²•°F)] per inch. Insulation not provided by Steelway Building Systems.
- Thermal block to have a maximum Thermal Conductivity of 0.029 W/(m•K) [0.20 BTU/(hr•FT²•°F)] per inch.
- Thermal tape to have a maximum Thermal Conductivity of 0.031 W/(m•K) [0.22 BTU/(hr•FT²•°F)] per inch.
- Standard 4" Batt insulation R14 (RSI 2.47) over the top of purlin sections.
- Minimum 1" (25mm) [R5 (RSI 0.88)] thermal block on top of purlins.
- Minimum 1/4" (6mm) [R1.15 (RSI 0.203)] thermal tape between chair and liner.
- Standard 1-7/8" hat section height.
- Effective U values for purlin spacing between modeled values can be extrapolated.
- 3D Thermal modeling conducted by Morrison Hershfield using steel building components manufactured by Steelway Building Systems. Software validated as part of ASHRAE Research Project 1365-RP.

Energy Code Requirements: Canada

Thermal CapLoc Roof System: Hat and Chair Stand-off Purlins at 6'-0", Ribs at 24" o/c

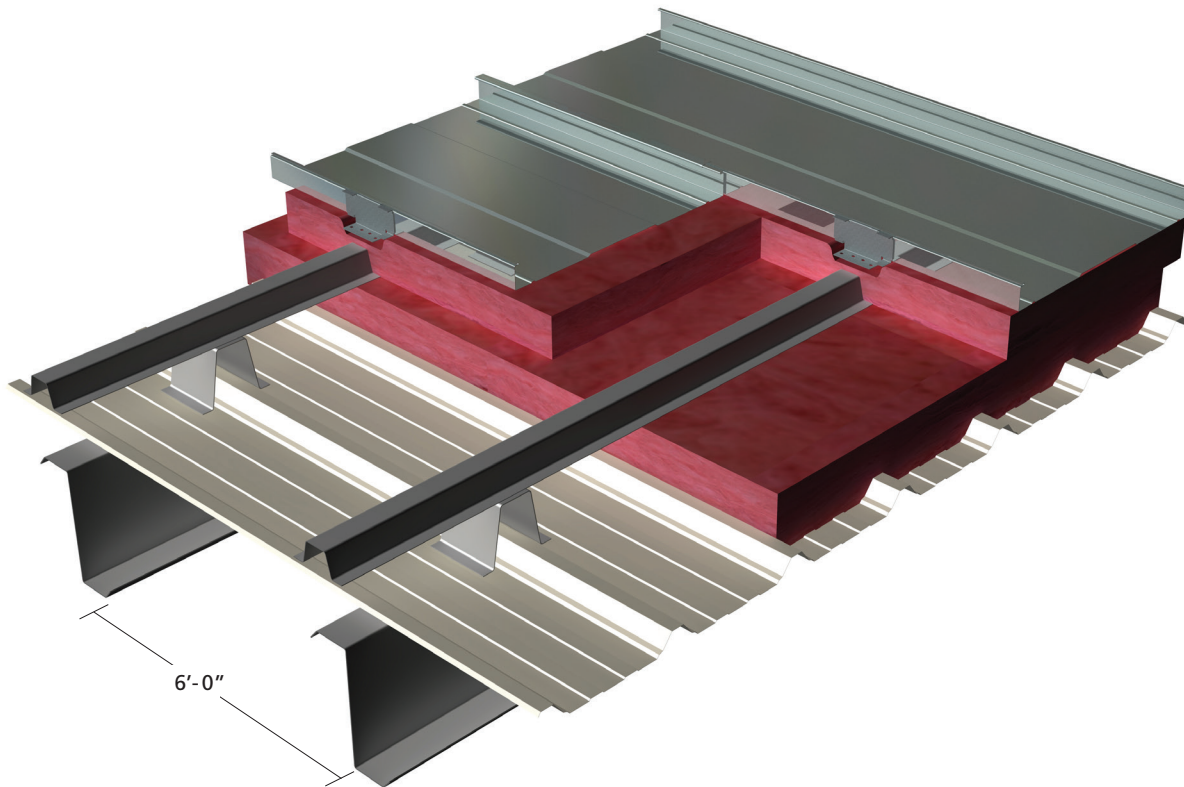

Purlins at 6'-0" with chairs spacing of 48" o/c, CapLoc roof (Ribs at 24" o/c)

Rated Value of Insulation (nominal)		Overall Insulation Thickness mm (in)	Chair Height mm (in)	Hat Height mm (in)	Effective Assembly U-Value W/(m ² K) (BTU/(hr•FT ² •°F))	Effective Assembly R-Value m ² K/W (hr•FT ² •°F/BTU)	Highest Zone Meet with NECB 2017 / OBC SB-10- 2016	Highest Zone Meet with ASHRAE 90.1-2013
RSI	R							
6.70 (4.23 + 2.47)	38 (24 + 14)	279 (11)	178 (7)	47.7 (1-7/8)	0.162 (0.028)	6.18 (R-35.1)	4	5A, 5B, 5C
7.23 (4.76 + 2.47)	41 (27 + 14)	305 (12)	203 (8)	47.7 (1-7/8)	0.150 (0.027)	6.65 (R-37.7)	6	6A, 6B
7.93 (5.46 + 2.47)	45 (31 + 14)	330 (13)	229 (9)	47.7 (1-7/8)	0.138 (0.024)	7.25 (R-41.2)	7A,7B	8
9.16 (6.69 + 2.47)	52 (38 + 14)	381 (15)	279 (11)	47.7 (1-7/8)	0.120 (0.021)	8.32 (R-47.2)	8	8
10.40 (7.93 + 2.47)	59 (45 + 14)	432 (17)	330 (13)	47.7 (1-7/8)	0.107 (0.019)	9.38 (R-53.3)	8	8

Notes:

- Standard Batt insulation with a maximum Thermal Conductivity of 0.042 W/(m•K) [0.29 BTU/(hr•FT²•°F)] per inch. Insulation not provided by Steelway Building Systems.
- Thermal block to have a maximum Thermal Conductivity of 0.029 W/(m•K) [0.20 BTU/(hr•FT²•°F)] per inch.
- Thermal tape to have a maximum Thermal Conductivity of 0.031 W/(m•K) [0.22 BTU/(hr•FT²•°F)] per inch.
- Standard 4" Batt insulation R14 (RSI 2.47) over the top of purlin sections.
- Minimum 1" (25mm) [R5 (RSI 0.88)] thermal block on top of purlins.
- Minimum 1/4" (6mm) [R1.15 (RSI 0.203)] thermal tape between chair and liner.
- Standard 1-7/8" hat section height.
- Effective U values for purlin spacing between modeled values can be extrapolated.
- 3D Thermal modeling conducted by Morrison Hershfield using steel building components manufactured by Steelway Building Systems. Software validated as part of ASHRAE Research Project 1365-RP.

Energy Code Requirements: Canada

Thermal CapLoc Roof System: Hat and Chair Stand-off Purlins at 2'-0", Ribs at 16" o/c

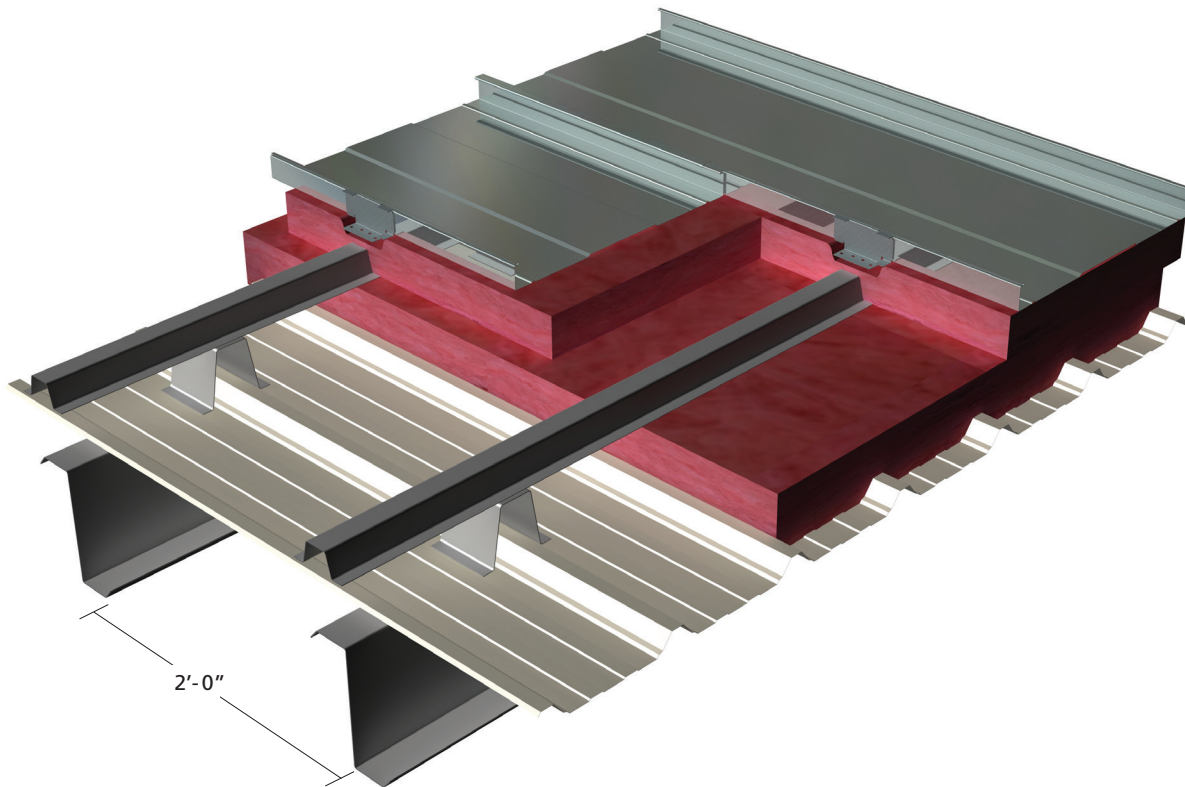

Purlins at 2'-0" with chairs spacing of 48" o/c, CapLoc roof (Ribs at 16" o/c)

Rated Value of Insulation (nominal)		Overall Insulation Thickness mm (in)	Chair Height mm (in)	Hat Height mm (in)	Effective Assembly U-Value W/(m²K) (BTU/(hr•FT²•°F))	Effective Assembly R-Value m²K/W (hr•FT²•°F/BTU)	Highest Zone Meet with NECB 2017 / OBC SB-10-2016	Highest Zone Meet with ASHRAE 90.1-2013
RSI	R							
6.70 (4.23 + 2.47)	38 (24 + 14)	279 (11)	178 (7)	47.7 (1-7/8)	0.186 (0.033)	5.36 (R-30.5)	4	5A, 5B, 5C
7.23 (4.76 + 2.47)	41 (27 + 14)	305 (12)	203 (8)	47.7 (1-7/8)	0.174 (0.031)	5.74 (R-32.6)	4	5A, 5B, 5C
7.93 (5.46 + 2.47)	45 (31 + 14)	330 (13)	229 (9)	47.7 (1-7/8)	0.161 (0.028)	6.20 (R-35.2)	4	5A, 5B, 5C
9.16 (6.69 + 2.47)	52 (38 + 14)	381 (15)	279 (11)	47.7 (1-7/8)	0.142 (0.025)	7.02 (R-39.9)	6	8
10.40 (7.93 + 2.47)	59 (45 + 14)	432 (17)	330 (13)	47.7 (1-7/8)	0.128 (0.023)	7.83 (R-44.4)	7A,7B	8

Notes:

- Standard Batt insulation with a maximum Thermal Conductivity of 0.042 W/(m•K) [0.29 BTU/(hr•FT²•°F)] per inch. Insulation not provided by Steelway Building Systems.
- Thermal block to have a maximum Thermal Conductivity of 0.029 W/(m•K) [0.20 BTU/(hr•FT²•°F)] per inch.
- Thermal tape to have a maximum Thermal Conductivity of 0.031 W/(m•K) [0.22 BTU/(hr•FT²•°F)] per inch.
- Standard 4" Batt insulation R14 (RSI 2.47) over the top of purlin sections.
- Minimum 1" (25mm) [R5 (RSI 0.88)] thermal block on top of purlins.
- Minimum 1/4" (6mm) [R1.15 (RSI 0.203)] thermal tape between chair and liner.
- Standard 1-7/8" hat section height.
- Effective U values for purlin spacing between modeled values can be extrapolated.
- 3D Thermal modeling conducted by Morrison Hershfield using steel building components manufactured by Steelway Building Systems. Software validated as part of ASHRAE Research Project 1365-RP.

Energy Code Requirements: Canada

Thermal CapLoc Roof System: Hat and Chair Stand-off Purlins at 2'-0", Ribs at 18" o/c

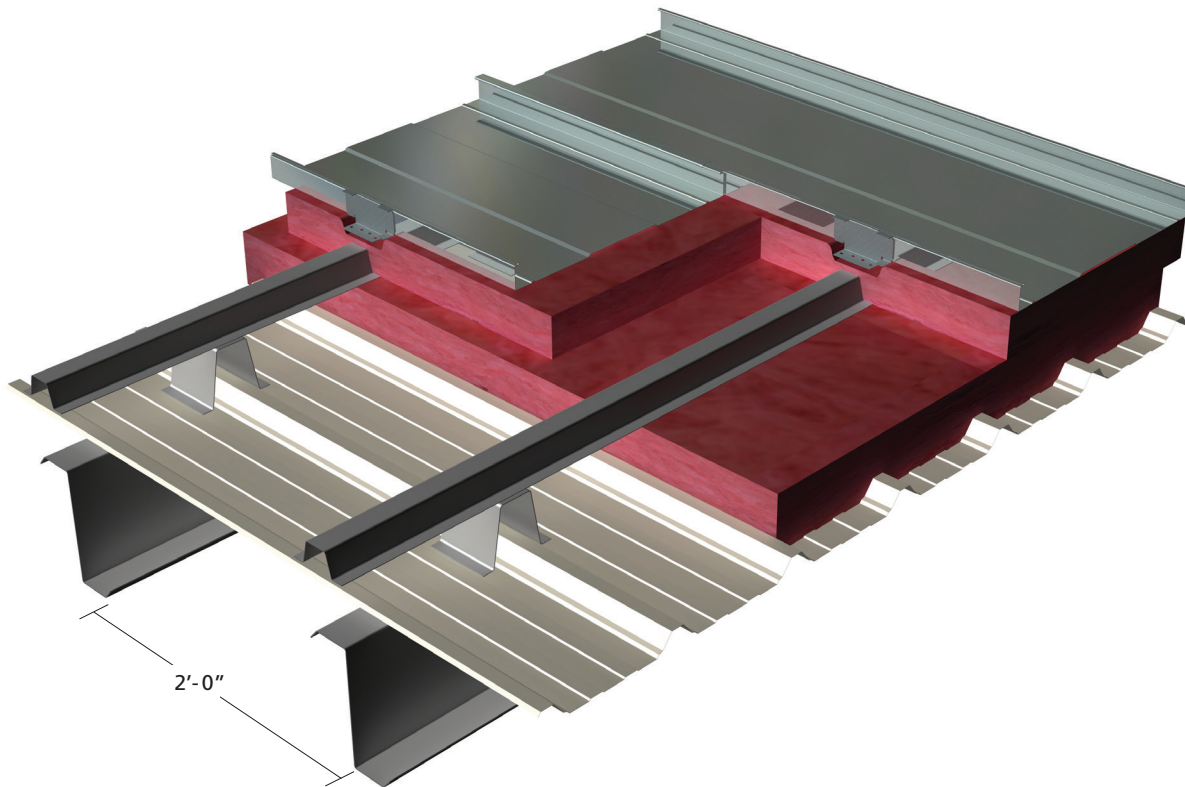

Purlins at 2'-0" with chairs spacing of 48" o/c, CapLoc roof (Ribs at 18" o/c)

Rated Value of Insulation (nominal)		Overall Insulation Thickness mm (in)	Chair Height mm (in)	Hat Height mm (in)	Effective Assembly U-Value W/(m²K) (BTU/(hr•FT²•°F))	Effective Assembly R-Value m²K/W (hr•FT²•°F/BTU)	Highest Zone Meet with NECB 2017 / OBC SB-10-2016	Highest Zone Meet with ASHRAE 90.1-2013
RSI	R							
6.70 (4.23 + 2.47)	38 (24 + 14)	279 (11)	178 (7)	47.7 (1-7/8)	0.188 (0.033)	5.33 (R-30.2)	4	5A, 5B, 5C
7.23 (4.76 + 2.47)	41 (27 + 14)	305 (12)	203 (8)	47.7 (1-7/8)	0.176 (0.031)	5.69 (R-32.3)	4	5A, 5B, 5C
7.93 (5.46 + 2.47)	45 (31 + 14)	330 (13)	229 (9)	47.7 (1-7/8)	0.162 (0.029)	6.16 (R-35.0)	4	5A, 5B, 5C
9.16 (6.69 + 2.47)	52 (38 + 14)	381 (15)	279 (11)	47.7 (1-7/8)	0.143 (0.025)	6.97 (R-39.6)	6	8
10.40 (7.93 + 2.47)	59 (45 + 14)	432 (17)	330 (13)	47.7 (1-7/8)	0.129 (0.023)	7.78 (R-44.2)	7A,7B	8

Notes:

- Standard Batt insulation with a maximum Thermal Conductivity of 0.042 W/(m•K) [0.29 BTU/(hr•FT²•°F)] per inch. Insulation not provided by Steelway Building Systems.
- Thermal block to have a maximum Thermal Conductivity of 0.029 W/(m•K) [0.20 BTU/(hr•FT²•°F)] per inch.
- Thermal tape to have a maximum Thermal Conductivity of 0.031 W/(m•K) [0.22 BTU/(hr•FT²•°F)] per inch.
- Standard 4" Batt insulation R14 (RSI 2.47) over the top of purlin sections.
- Minimum 1" (25mm) [R5 (RSI 0.88)] thermal block on top of purlins.
- Minimum 1/4" (6mm) [R1.15 (RSI 0.203)] thermal tape between chair and liner.
- Standard 1-7/8" hat section height.
- Effective U values for purlin spacing between modeled values can be extrapolated.
- 3D Thermal modeling conducted by Morrison Hershfield using steel building components manufactured by Steelway Building Systems. Software validated as part of ASHRAE Research Project 1365-RP.

Energy Code Requirements: Canada

Thermal CapLoc Roof System: Hat and Chair Stand-off Purlins at 2'-0", Ribs at 24" o/c

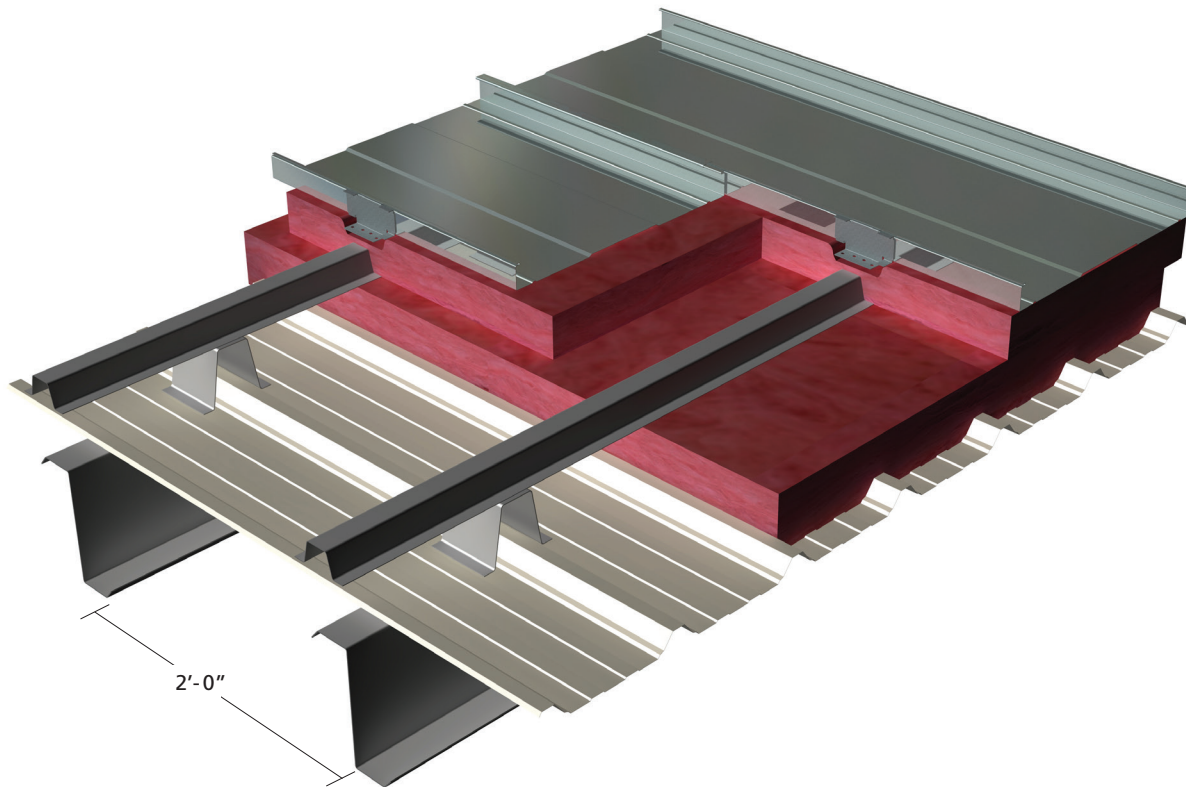

Purlins at 2'-0" with chairs spacing of 48" o/c, CapLoc roof (Ribs at 24" o/c)

Rated Value of Insulation (nominal)		Overall Insulation Thickness mm (in)	Chair Height mm (in)	Hat Height mm (in)	Effective Assembly U-Value W/(m ² K) (BTU/(hr•FT ² •°F))	Effective Assembly R-Value m ² K/W (hr•FT ² •°F/BTU)	Highest Zone Meet with NECB 2017 / OBC SB-10- 2016	Highest Zone Meet with ASHRAE 90.1-2013
RSI	R							
6.70 (4.23 + 2.47)	38 (24 + 14)	279 (11)	178 (7)	47.7 (1-7/8)	0.184 (0.032)	5.43 (R-30.8)	4	5A, 5B, 5C
7.23 (4.76 + 2.47)	41 (27 + 14)	305 (12)	203 (8)	47.7 (1-7/8)	0.173 (0.030)	5.79 (R-32.9)	4	5A, 5B, 5C
7.93 (5.46 + 2.47)	45 (31 + 14)	330 (13)	229 (9)	47.7 (1-7/8)	0.160 (0.028)	6.26 (R-35.5)	4	5A, 5B, 5C
9.16 (6.69 + 2.47)	52 (38 + 14)	381 (15)	279 (11)	47.7 (1-7/8)	0.141 (0.025)	7.09 (R-40.3)	6	8
10.40 (7.93 + 2.47)	59 (45 + 14)	432 (17)	330 (13)	47.7 (1-7/8)	0.126 (0.022)	7.91 (R-44.9)	7A,7B	8

Notes:

- Standard Batt insulation with a maximum Thermal Conductivity of 0.042 W/(m•K) [0.29 BTU/(hr•FT²•°F)] per inch. Insulation not provided by Steelway Building Systems.
- Thermal block to have a maximum Thermal Conductivity of 0.029 W/(m•K) [0.20 BTU/(hr•FT²•°F)] per inch.
- Thermal tape to have a maximum Thermal Conductivity of 0.031 W/(m•K) [0.22 BTU/(hr•FT²•°F)] per inch.
- Standard 4" Batt insulation R14 (RSI 2.47) over the top of purlin sections.
- Minimum 1" (25mm) [R5 (RSI 0.88)] thermal block on top of purlins.
- Minimum 1/4" (6mm) [R1.15 (RSI 0.203)] thermal tape between chair and liner.
- Standard 1-7/8" hat section height.
- Effective U values for purlin spacing between modeled values can be extrapolated.
- 3D Thermal modeling conducted by Morrison Hershfield using steel building components manufactured by Steelway Building Systems. Software validated as part of ASHRAE Research Project 1365-RP.

Thermal Standing Seam Roof System: Cavity Filled Purlins at 5'-0"

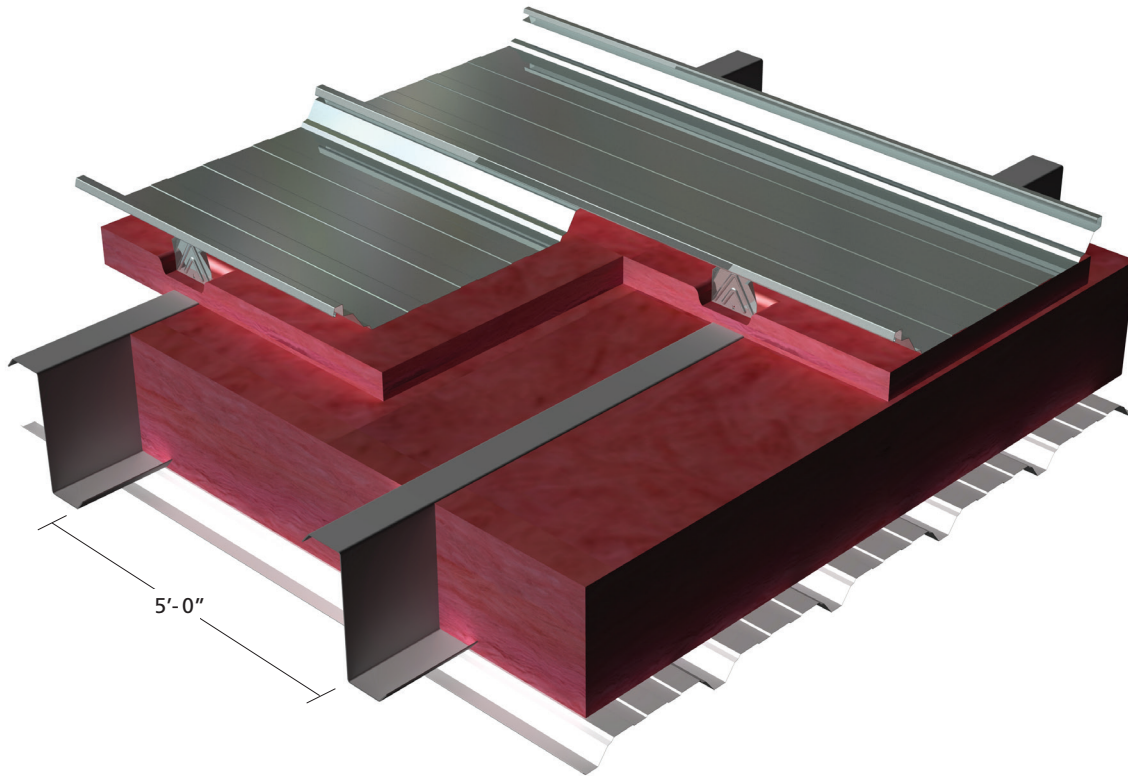

Purlins at 5'-0", RTL-24 roof with liner

Rated Value of Insulation (nominal)		Overall Insulation Thickness mm (in)	Purlin Height mm (in)	Effective Assembly U-Value W/(m ² K) (BTU/(hr•FT ² •°F))	Effective Assembly R-Value m ² K/W (hr•FT ² •°F/BTU)	Highest Zone Meet with NECB 2017 / OBC SB-10- 2016	Highest Zone Meet with ASHRAE 90.1-2013
RSI	R						
6.87 (4.40 + 2.47)	39 (25 + 14)	305 (12)	203 (8)	0.228 (0.040)	4.38 (R-24.9)	–	–
8.27 (5.80 + 2.47)	47 (33 + 14)	356 (14)	254 (10)	0.203 (0.036)	4.92 (R-27.9)	–	4A, 4B, 4C
9.16 (6.69 + 2.47)	52 (38 + 14)	407 (16)	305 (12)	0.183 (0.032)	5.46 (R-31.0)	4	5A, 5B, 5C
*10.57 (6.69 + 3.88)	*60 (38 + 22)	*458 (18)	305 (12)	0.158 (0.028)	6.34 (R-36.0)	4	6A, 6B

Notes:

- Standard Batt insulation with a maximum Thermal Conductivity of 0.042 W/(m•K) [0.29 BTU/(hr•FT²•°F)] per inch. Insulation not provided by Steelway Building Systems.
- Thermal block to have a maximum Thermal Conductivity of 0.029 W/(m•K) [0.20 BTU/(hr•FT²•°F)] per inch.
- Standard 4" Batt insulation R14 (RSI 2.47) over the top of purlin sections.
- Minimum 1" (25mm) [R5 (RSI 0.88)] thermal block on top of purlins.
- Steel liner or Simple Saver underside of purlins.
- Effective U values for purlin spacing between modeled values can be extrapolated.
- 3D Thermal modeling conducted by Morrison Hershfield using steel building components manufactured by Steelway Building Systems. Software validated as part of ASHRAE Research Project 1365-RP.
- *RTL 6" High Clip used with Two (2) Standard 3" Batt insulation [Each R11 (RSI 1.94)] over the top of purlin sections.

Thermal Standing Seam Roof System: Cavity Filled Purlins at 2'-0"

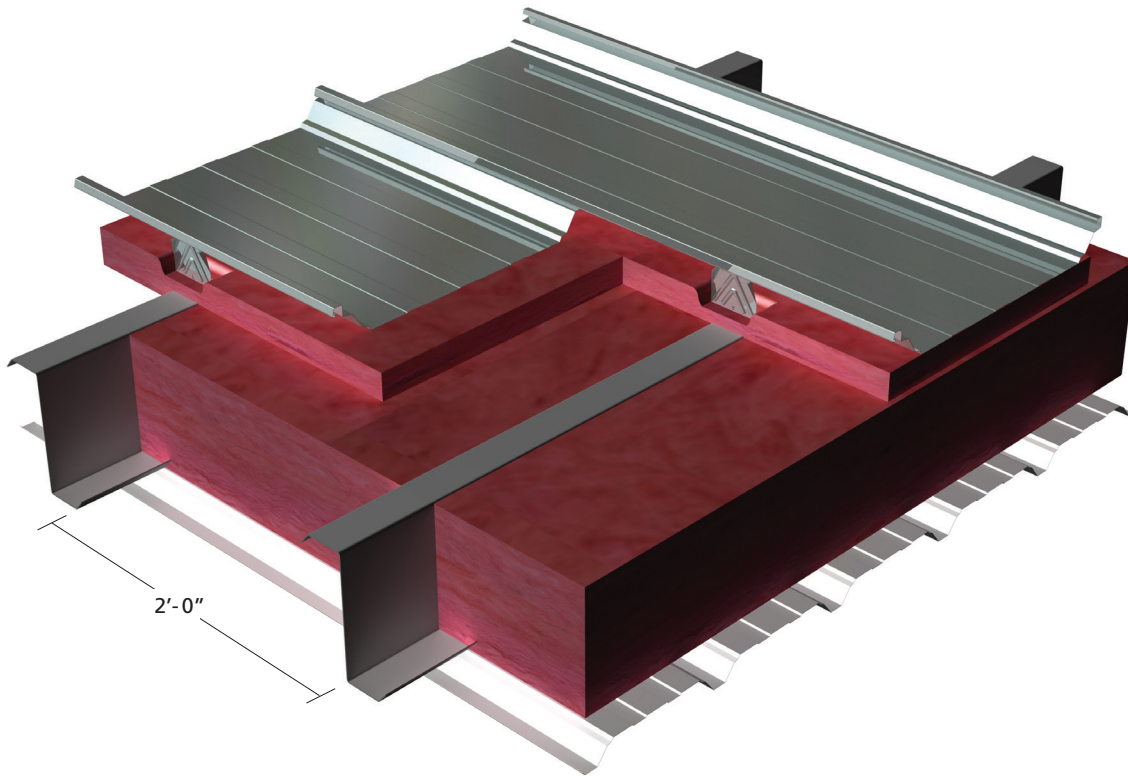

Purlins at 2'-0", RTL-24 roof with liner

Rated Value of Insulation (nominal)		Overall Insulation Thickness mm (in)	Purlin Height mm (in)	Effective Assembly U-Value W/(m ² K) (BTU/(hr•FT ² •°F))	Effective Assembly R-Value m ² K/W (hr•FT ² •°F/BTU)	Highest Zone Meet with NECB 2017 / OBC SB-10- 2016	Highest Zone Meet with ASHRAE 90.1-2013
RSI	R						
6.87 (4.40 + 2.47)	39 (25 + 14)	305 (12)	203 (8)	0.328 (0.058)	3.04 (R-17.3)	–	–
8.27 (5.80 + 2.47)	47 (33 + 14)	356 (14)	254 (10)	0.306 (0.054)	3.27 (R-18.6)	–	–
9.16 (6.69 + 2.47)	52 (38 + 14)	407 (16)	305 (12)	0.286 (0.050)	3.49 (R-19.8)	–	–
*10.57 (6.69 + 3.88)	*60 (38 + 22)	*458 (18)	305 (12)	0.239 (0.042)	4.18 (R-23.7)	–	–

Notes:

- Standard Batt insulation with a maximum Thermal Conductivity of 0.042 W/(m•K) [0.29 BTU/(hr•FT²•°F)] per inch. Insulation not provided by Steelway Building Systems.
- Thermal block to have a maximum Thermal Conductivity of 0.029 W/(m•K) [0.20 BTU/(hr•FT²•°F)] per inch.
- Standard 4" Batt insulation R14 (RSI 2.47) over the top of purlin sections.
- Minimum 1" (25mm) [R5 (RSI 0.88)] thermal block on top of purlins.
- Steel liner or Simple Saver underside of purlins.
- Effective U values for purlin spacing between modeled values can be extrapolated.
- 3D Thermal modeling conducted by Morrison Hershfield using steel building components manufactured by Steelway Building Systems. Software validated as part of ASHRAE Research Project 1365-RP.
- *RTL 6" High Clip used with Two (2) Standard 3" Batt insulation [Each R11 (RSI 1.94)] over the top of purlin sections.

Energy Code Requirements: Canada

Thermal Standing Seam Roof System: Cavity Filled w/ 1.5" Bottom Flange Thermal Block

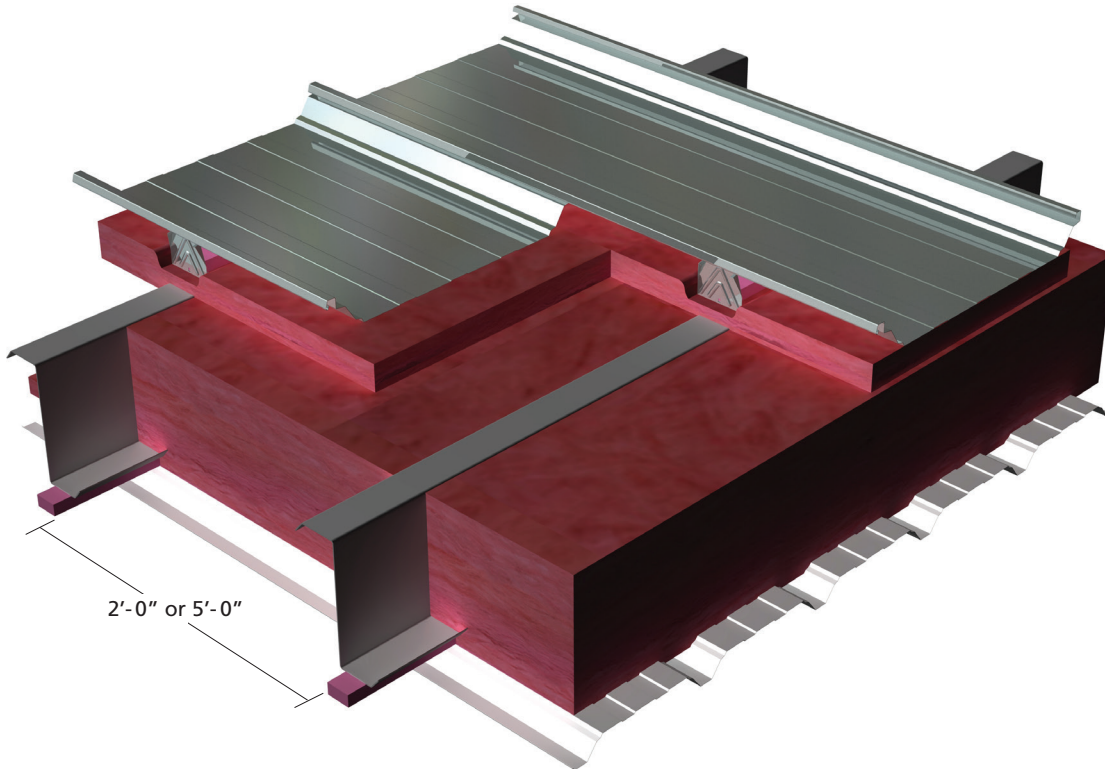

RTL-24 roof with liner, purlin spacing as listed below

Purlin Spacing mm (ft)	Rated Value of Insulation (nominal)		Overall Insulation Thickness mm (in)	Purlin Height mm (in)	Effective Assembly U-Value W/(m ² K) (BTU/(hr•FT ² •°F))	Effective Assembly R-Value m ² K/W (hr•FT ² •°F/BTU)	Highest Zone Meet with NECB 2017 / OBC SB-10- 2016	Highest Zone Meet with ASHRAE 90.1-2013
	RSI	R						
1524 (5'-0")	11.45 (7.57 + 3.88)	65 (43 + 22)	495 (19.5)	305 (12)	0.104 (0.018)	9.62 (R-54.6)	8	8
610 (2'-0")	11.45 (7.57 + 3.88)	65 (43 + 22)	495 (19.5)	305 (12)	0.131 (0.023)	7.64 (R-43.4)	7A, 7B	8

Notes:

- Assumes cavity is filled with Two (2) layers of Batt insulation: 9" Batt [R30 (RSI 5.28)] & 4.5" Batt [R13 (RSI 2.29)]. Insulation not provided by Steelway Building Systems.
- Two (2) Standard 3" Batt insulation [Each R11 (RSI 1.94)] over the top of purlin sections
- Minimum 1" (25mm) [R5 (RSI 0.88)] thermal block on top of purlins.
- Minimum 1.5" (38mm) [R7.5 (RSI 1.31)] thermal block on bottom of purlins.
- Standard Batt insulation with a maximum Thermal Conductivity of 0.042 W/(m•K) [0.20 BTU/(hr•FT²•°F)] per inch.
- Thermal block's to have a maximum Thermal Conductivity of 0.029 W/(m•K) [0.20 BTU/(hr•FT²•°F)] per inch.
- Steel liner or Simple Saver underside of purlins
- Effective U values for purlin spacing between modeled values can be extrapolated.
- 3D Thermal modeling conducted by Morrison Hershfield using steel building components manufactured by Steelway Building Systems. Software validated as part of ASHRAE Research Project 1365-RP.
- RTL 6" High Clip used.

Energy Code Requirements: Canada

Thermal CapLoc Roof System: Cavity Filled Purlins at 6'-0", Ribs at 16" o/c

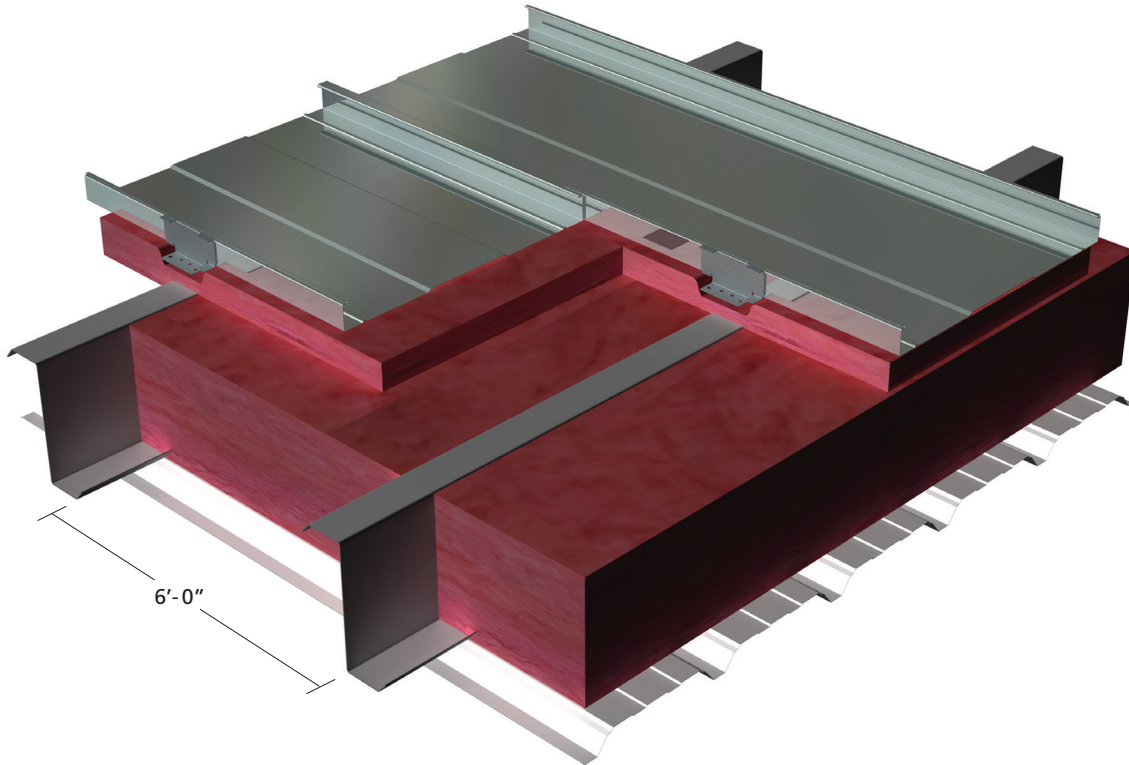

Purlins at 6'-0", CapLoc roof (Ribs at 16" o/c)

Rated Value of Insulation (nominal)		Overall Insulation Thickness mm (in)	Purlin Height mm (in)	Effective Assembly U-Value W/(m ² K) (BTU/(hr•FT ² •°F))	Effective Assembly R-Value m ² K/W (hr•FT ² •°F/BTU)	Highest Zone Meet with NECB 2017 / OBC SB-10- 2016	Highest Zone Meet with ASHRAE 90.1-2013
RSI	R						
6.87 (4.40 + 2.47)	39 (25 + 14)	305 (12)	203 (8)	0.188 (0.033)	5.31 (R-30.1)	4	5A, 5B, 5C
8.27 (5.80 + 2.47)	47 (33 + 14)	356 (14)	254 (10)	0.164 (0.029)	6.10 (R-34.6)	4	5A, 5B, 5C
9.16 (6.69 + 2.47)	52 (38 + 14)	407 (16)	305 (12)	0.153 (0.027)	6.54 (R-37.1)	6	6A, 6B

Notes:

- Standard Batt insulation with a maximum Thermal Conductivity of 0.042 W/(m•K) [0.29 BTU/(hr•FT²•°F)] per inch. Insulation not provided by Steelway Building Systems.
- Thermal block to have a maximum Thermal Conductivity of 0.029 W/(m•K) [0.20 BTU/(hr•FT²•°F)] per inch.
- Standard 4" Batt insulation R14 (RSI 2.47) over the top of purlin sections.
- Minimum 1" (25mm) [R5 (RSI 0.88)] thermal block on top of purlins.
- Steel liner or Simple Saver underside of purlins.
- Effective U values for purlin spacing between modeled values can be extrapolated.
- 3D Thermal modeling conducted by Morrison Hershfield using steel building components manufactured by Steelway Building Systems. Software validated as part of ASHRAE Research Project 1365-RP.
- CapLoc High Clip used.

Energy Code Requirements: Canada

Thermal CapLoc Roof System: Cavity Filled Purlins at 6'-0", Ribs at 18" o/c

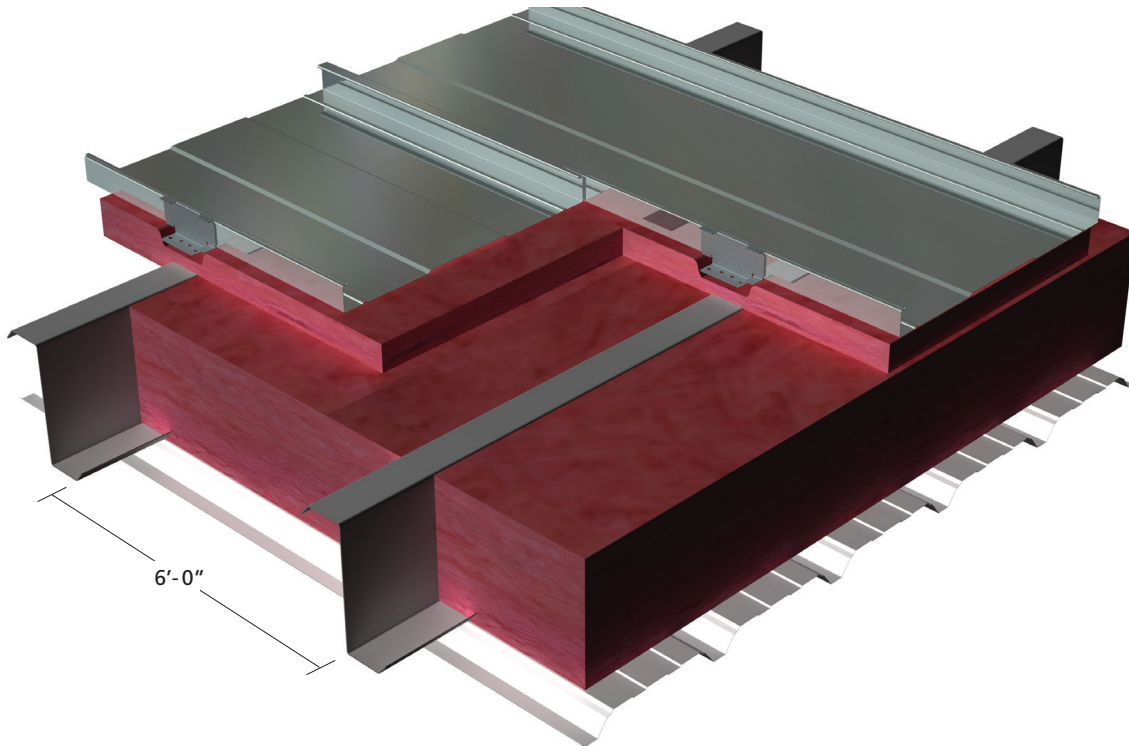

Purlins at 6'-0", CapLoc roof (Ribs at 18" o/c)

Rated Value of Insulation (nominal)		Overall Insulation Thickness mm (in)	Purlin Height mm (in)	Effective Assembly U-Value W/(m ² K) (BTU/(hr•FT ² •°F))	Effective Assembly R-Value m ² K/W (hr•FT ² •°F/BTU)	Highest Zone Meet with NECB 2017 / OBC SB-10- 2016	Highest Zone Meet with ASHRAE 90.1-2013
RSI	R						
6.87 (4.40 + 2.47)	39 (25 + 14)	305 (12)	203 (8)	0.187 (0.033)	5.35 (R-30.4)	4	5A, 5B, 5C
8.27 (5.80 + 2.47)	47 (33 + 14)	356 (14)	254 (10)	0.162 (0.029)	6.15 (R-34.9)	4	5A, 5B, 5C
9.16 (6.69 + 2.47)	52 (38 + 14)	407 (16)	305 (12)	0.151 (0.027)	6.61 (R-37.5)	6	6A, 6B

Notes:

- Standard Batt insulation with a maximum Thermal Conductivity of 0.042 W/(m•K) [0.29 BTU/(hr•FT²•°F)] per inch. Insulation not provided by Steelway Building Systems.
- Thermal block to have a maximum Thermal Conductivity of 0.029 W/(m•K) [0.20 BTU/(hr•FT²•°F)] per inch.
- Standard 4" Batt insulation R14 (RSI 2.47) over the top of purlin sections.
- Minimum 1" (25mm) [R5 (RSI 0.88)] thermal block on top of purlins.
- Steel liner or Simple Saver underside of purlins.
- Effective U values for purlin spacing between modeled values can be extrapolated.
- 3D Thermal modeling conducted by Morrison Hershfield using steel building components manufactured by Steelway Building Systems. Software validated as part of ASHRAE Research Project 1365-RP.
- CapLoc High Clip used.

Energy Code Requirements: Canada

Thermal CapLoc Roof System: Cavity Filled Purlins at 6'-0", Ribs at 24" o/c

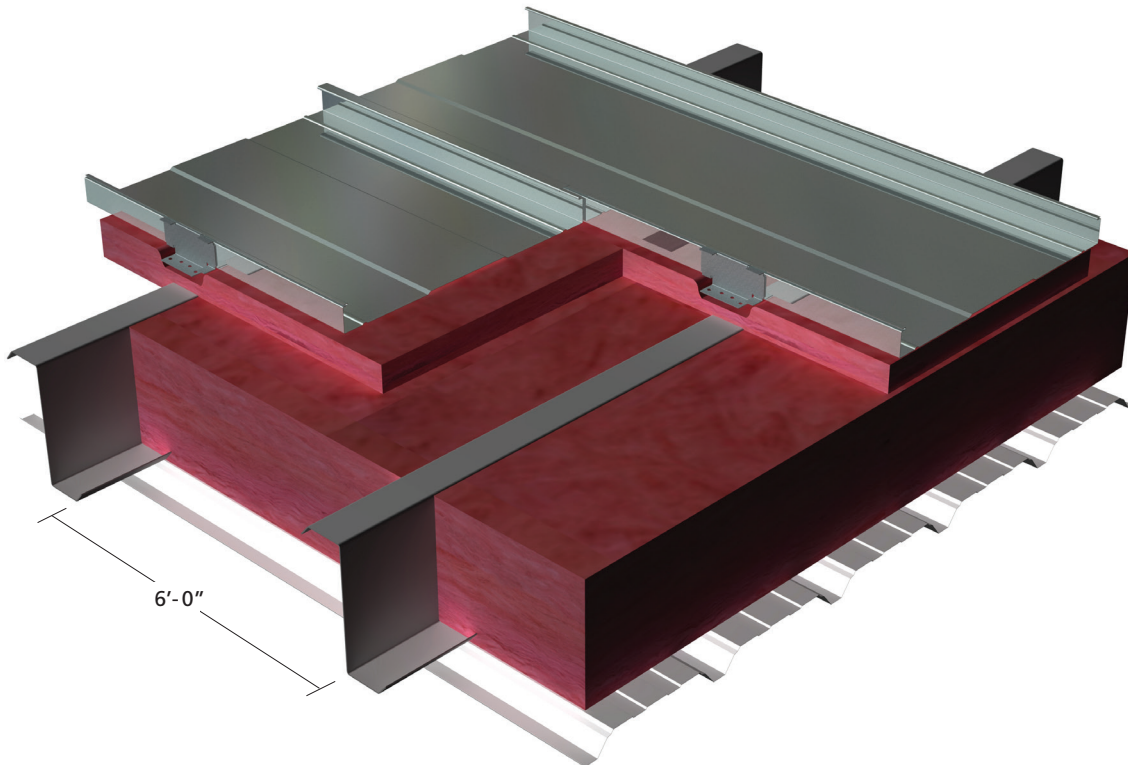

Purlins at 6'-0", CapLoc roof (Ribs at 24"o/c)

Rated Value of Insulation (nominal)		Overall Insulation Thickness mm (in)	Purlin Height mm (in)	Effective Assembly U-Value W/(m ² K) (BTU/(hr•FT ² •°F))	Effective Assembly R-Value m ² K/W (hr•FT ² •°F/BTU)	Highest Zone Meet with NECB 2017 / OBC SB-10-2016	Highest Zone Meet with ASHRAE 90.1-2013
RSI	R						
6.87 (4.40 + 2.47)	39 (25 + 14)	305 (12)	203 (8)	0.184 (0.032)	5.43 (R-30.8)	4	5A, 5B, 5C
8.27 (5.80 + 2.47)	47 (33 + 14)	356 (14)	254 (10)	0.160 (0.028)	6.25 (R-35.5)	4	5A, 5B, 5C
9.16 (6.69 + 2.47)	52 (38 + 14)	407 (16)	305 (12)	0.149 (0.026)	6.71 (R-38.1)	6	6A, 6B

Notes:

- Standard Batt insulation with a maximum Thermal Conductivity of 0.042 W/(m•K) [0.29 BTU/(hr•FT²•°F)] per inch. Insulation not provided by Steelway Building Systems.
- Thermal block to have a maximum Thermal Conductivity of 0.029 W/(m•K) [0.20 BTU/(hr•FT²•°F)] per inch.
- Standard 4" Batt insulation R14 (RSI 2.47) over the top of purlin sections.
- Minimum 1" (25mm) [R5 (RSI 0.88)] thermal block on top of purlins.
- Steel liner or Simple Saver underside of purlins.
- Effective U values for purlin spacing between modeled values can be extrapolated.
- 3D Thermal modeling conducted by Morrison Hershfield using steel building components manufactured by Steelway Building Systems. Software validated as part of ASHRAE Research Project 1365-RP.
- CapLoc High Clip used.

Energy Code Requirements: Canada

Thermal CapLoc Roof System: Cavity Filled Purlins at 2'-0", Ribs at 16" o/c

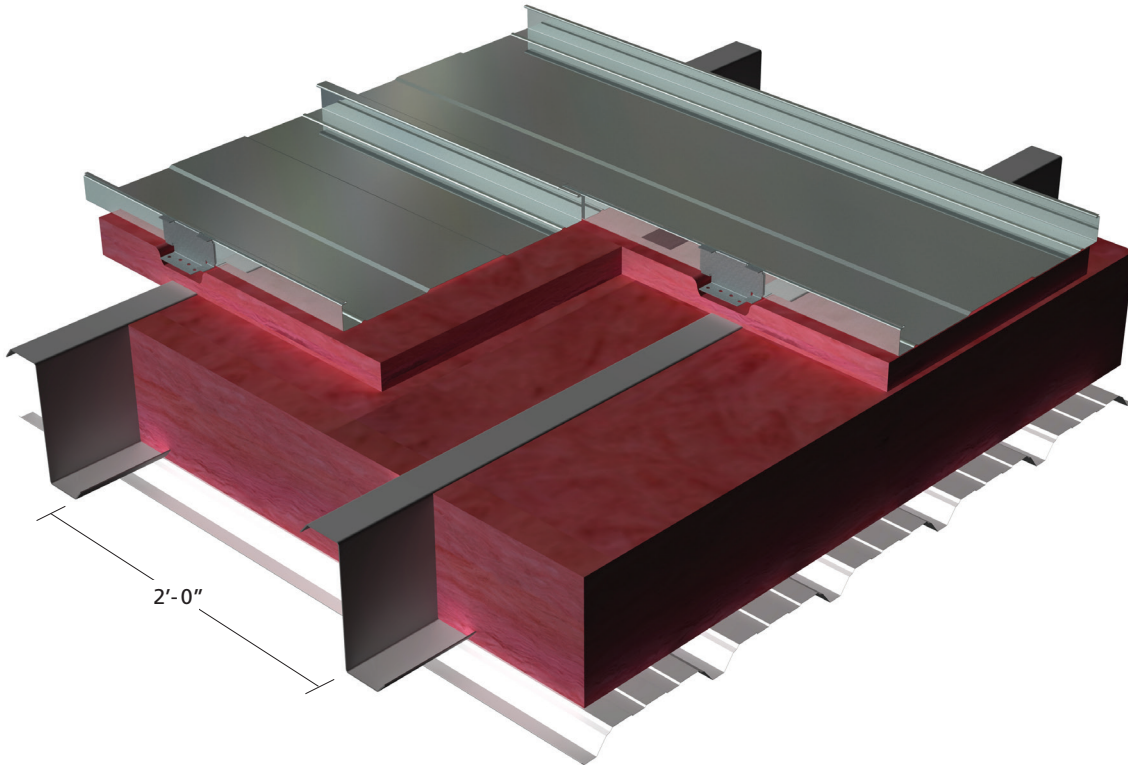

Purlins at 2'-0", CapLoc roof (Ribs at 16" o/c)

Rated Value of Insulation (nominal)		Overall Insulation Thickness mm (in)	Purlin Height mm (in)	Effective Assembly U-Value W/(m ² K) (BTU/(hr•FT ² •°F))	Effective Assembly R-Value m ² K/W (hr•FT ² •°F/BTU)	Highest Zone Meet with NECB 2017 / OBC SB-10-2016	Highest Zone Meet with ASHRAE 90.1-2013
RSI	R						
6.87 (4.40 + 2.47)	39 (25 + 14)	305 (12)	203 (8)	0.263 (0.046)	3.80 (R-21.6)	–	–
8.27 (5.80 + 2.47)	47 (33 + 14)	356 (14)	254 (10)	0.243 (0.043)	4.12 (R-23.4)	–	–
9.16 (6.69 + 2.47)	52 (38 + 14)	407 (16)	305 (12)	0.235 (0.041)	4.26 (R-24.2)	–	–

Notes:

- Standard Batt insulation with a maximum Thermal Conductivity of 0.042 W/(m•K) [0.29 BTU/(hr•FT²•°F)] per inch. Insulation not provided by Steelway Building Systems.
- Thermal block to have a maximum Thermal Conductivity of 0.029 W/(m•K) [0.20 BTU/(hr•FT²•°F)] per inch.
- Standard 4" Batt insulation R14 (RSI 2.47) over the top of purlin sections.
- Minimum 1" (25mm) [R5 (RSI 0.88)] thermal block on top of purlins.
- Steel liner or Simple Saver underside of purlins.
- Effective U values for purlin spacing between modeled values can be extrapolated.
- 3D Thermal modeling conducted by Morrison Hershfield using steel building components manufactured by Steelway Building Systems. Software validated as part of ASHRAE Research Project 1365-RP.
- CapLoc High Clip used.

Energy Code Requirements: Canada

Thermal CapLoc Roof System: Cavity Filled Purlins at 2'-0", Ribs at 18" o/c

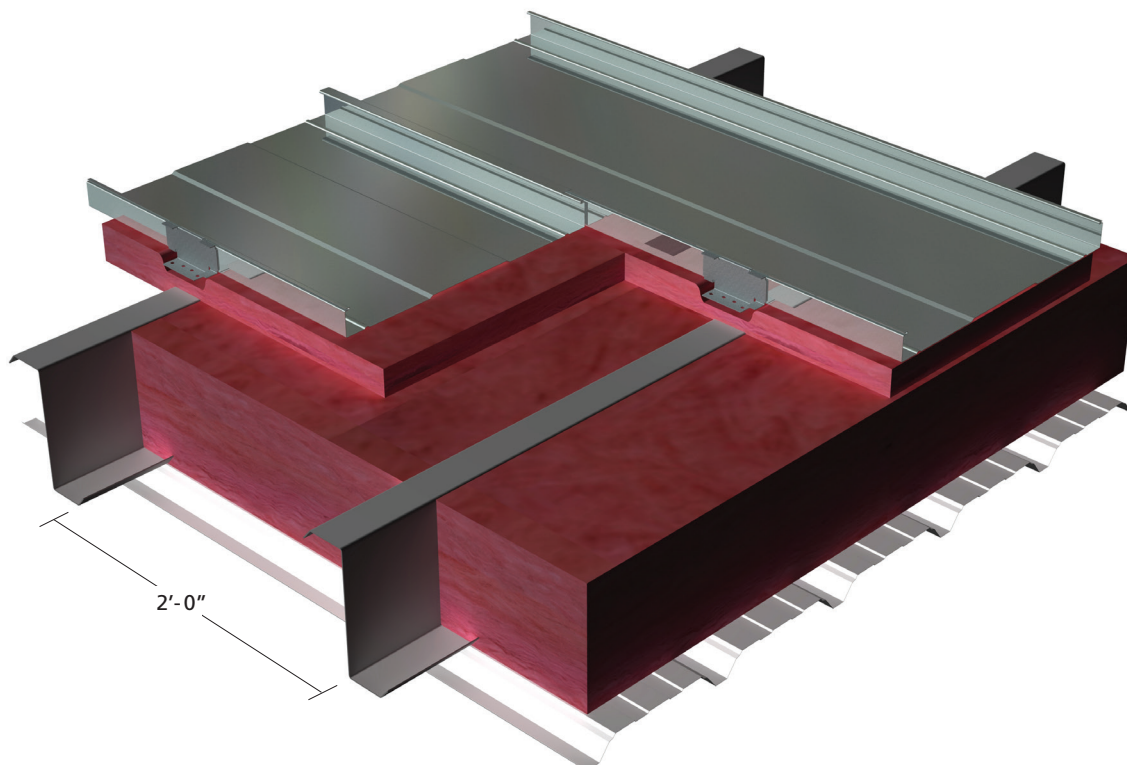

Purlins at 2'-0", CapLoc roof (Ribs at 18" o/c)

Rated Value of Insulation (nominal)		Overall Insulation Thickness mm (in)	Purlin Height mm (in)	Effective Assembly U-Value W/(m ² K) (BTU/(hr•FT ² •°F))	Effective Assembly R-Value m ² K/W (hr•FT ² •°F/BTU)	Highest Zone Meet with NECB 2017 / OBC SB-10- 2016	Highest Zone Meet with ASHRAE 90.1-2013
RSI	R						
6.87 (4.40 + 2.47)	39 (25 + 14)	305 (12)	203 (8)	0.257 (0.045)	3.89 (R-21.1)	–	–
8.27 (5.80 + 2.47)	47 (33 + 14)	356 (14)	254 (10)	0.237 (0.042)	4.22 (R-23.9)	–	–
9.16 (6.69 + 2.47)	52 (38 + 14)	407 (16)	305 (12)	0.228 (0.040)	4.38 (R-24.9)	–	–

Notes:

- Standard Batt insulation with a maximum Thermal Conductivity of 0.042 W/(m•K) [0.29 BTU/(hr•FT²•°F)] per inch. Insulation not provided by Steelway Building Systems.
- Thermal block to have a maximum Thermal Conductivity of 0.029 W/(m•K) [0.20 BTU/(hr•FT²•°F)] per inch.
- Standard 4" Batt insulation R14 (RSI 2.47) over the top of purlin sections.
- Minimum 1" (25mm) [R5 (RSI 0.88)] thermal block on top of purlins.
- Steel liner or Simple Saver underside of purlins.
- Effective U values for purlin spacing between modeled values can be extrapolated.
- 3D Thermal modeling conducted by Morrison Hershfield using steel building components manufactured by Steelway Building Systems. Software validated as part of ASHRAE Research Project 1365-RP.
- CapLoc High Clip used.

Energy Code Requirements: Canada

Thermal CapLoc Roof System: Cavity Filled Purlins at 2'-0", Ribs at 24" o/c

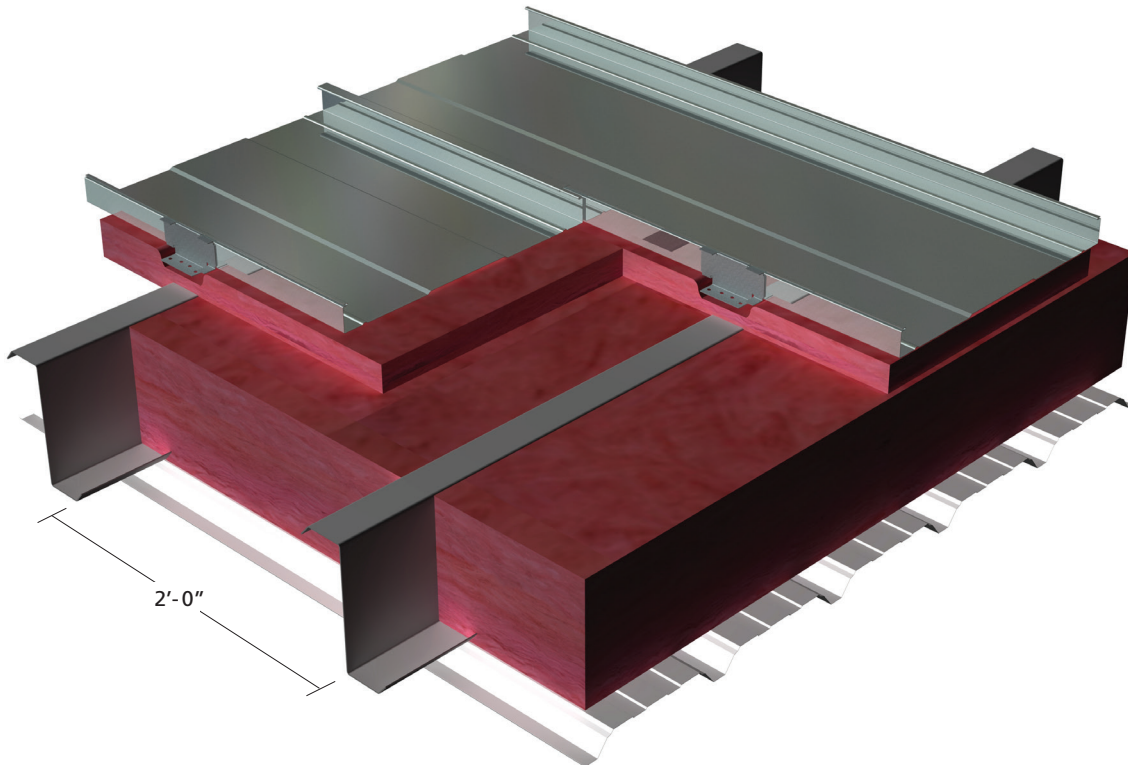

Purlins at 2'-0", CapLoc roof (Ribs at 24" o/c)

Rated Value of Insulation (nominal)		Overall Insulation Thickness mm (in)	Purlin Height mm (in)	Effective Assembly U-Value W/(m ² K) (BTU/(hr•FT ² •°F))	Effective Assembly R-Value m ² K/W (hr•FT ² •°F/BTU)	Highest Zone Meet with NECB 2017 / OBC SB-10- 2016	Highest Zone Meet with ASHRAE 90.1-2013
RSI	R						
6.87 (4.40 + 2.47)	39 (25 + 14)	305 (12)	203 (8)	0.249 (0.044)	4.01 (R-22.8)	-	-
8.27 (5.80 + 2.47)	47 (33 + 14)	356 (14)	254 (10)	0.238 (0.042)	4.21 (R-23.9)	-	-
9.16 (6.69 + 2.47)	52 (38 + 14)	407 (16)	305 (12)	0.221 (0.039)	4.52 (R-25.6)	-	-

Notes:

- Standard Batt insulation with a maximum Thermal Conductivity of 0.042 W/(m•K) [0.29 BTU/(hr•FT²•°F)] per inch. Insulation not provided by Steelway Building Systems.
- Thermal block to have a maximum Thermal Conductivity of 0.029 W/(m•K) [0.20 BTU/(hr•FT²•°F)] per inch.
- Standard 4" Batt insulation R14 (RSI 2.47) over the top of purlin sections.
- Minimum 1" (25mm) [R5 (RSI 0.88)] thermal block on top of purlins.
- Steel liner or Simple Saver underside of purlins.
- Effective U values for purlin spacing between modeled values can be extrapolated.
- 3D Thermal modeling conducted by Morrison Hershfield using steel building components manufactured by Steelway Building Systems. Software validated as part of ASHRAE Research Project 1365-RP.
- CapLoc High Clip used.

Thermal Wall System: Standard

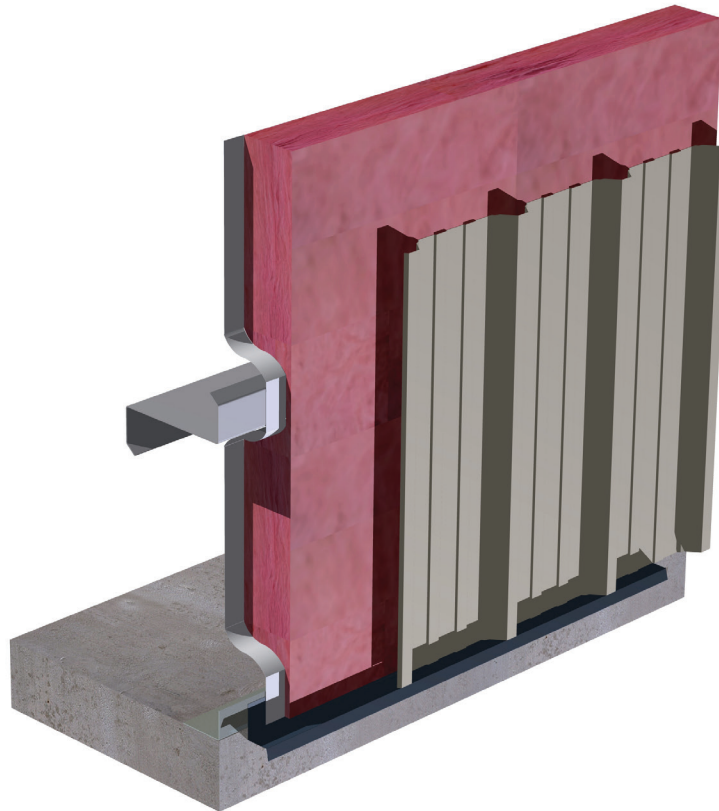

StormSeal panel with faced insulation draped outside wall girts, girt spacing as listed below

Girt Spacing mm (ft)	Rated Value of Insulation (nominal)		Overall Insulation Thickness mm (in)	Effective Assembly U-Value W/(m ² K) (BTU/(hr•FT ² •°F))	Effective Assembly R-Value m ² K/W (hr•FT ² •°F/BTU)
	RSI	R			
1524 (5'-0")	3.35	19	152 (6)	0.513 (0.090)	1.95 (R-11.1)
610 (2'-0")	3.35	19	152 (6)	0.857 (0.151)	1.17 (R-6.6)

Notes:

- Standard Batt insulation with a maximum Thermal Conductivity of 0.042 W/(m•K) [0.29 BTU/(hr•FT²•°F)] per inch. Insulation not provided by Steelway Building Systems.
- Effective U values for girt spacing between modeled values can be extrapolated.
- 3D Thermal modeling conducted by Morrison Hershfield using steel building components manufactured by Steelway Building Systems. Software validated as part of ASHRAE Research Project 1365-RP.

Energy Code Requirements: Canada

Thermal Wall System: Cavity Filled - Narrow Rib Out Girts at 5'-0"

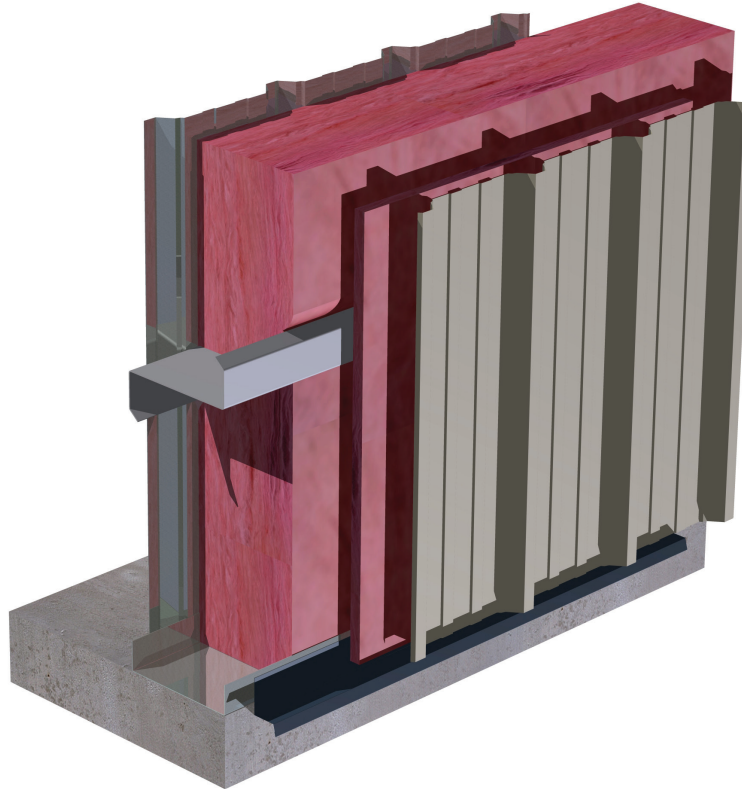

Girts at 5'-0" (minimum spacing), StormSeal exterior panels with interior liner

Rated Value of Insulation (nominal)		Overall Insulation Thickness mm (in)	Girt Depth mm (in)	Effective Assembly U-Value W/(m ² K) (BTU/(hr•FT ² •°F))	Effective Assembly R-Value m ² K/W (hr•FT ² •°F/BTU)	Highest Zone Meet with NECB 2017 / OBC SB-10- 2016	Highest Zone Meet with ASHRAE 90.1-2013
RSI	R						
6.34 (4.40+1.94)	36 (25 + 11)	279 (11)	203 (8)	0.320 (0.056)	3.13 (R-17.7)	–	4A, 4B, 4C
7.74 (5.80+1.94)	44 (33 + 11)	330 (13)	254 (10)	0.280 (0.049)	3.57 (R-20.3)	4	4A, 4B, 4C
8.63 (6.69+1.94)	49 (38 + 11)	381 (15)	305 (12)	0.250 (0.044)	3.99 (R-22.7)	5	5A,5B, 5C

Notes:

- Standard Batt insulation with a maximum Thermal Conductivity of 0.042 W/(m•K) [0.29 BTU/(hr•FT²•°F)] per inch. Insulation not provided by Steelway Building Systems.
- Standard 3" Batt insulation R11 (RSI 1.94) over the top of girt sections.
- Steel liner on girt inside flange.
- Effective U values for girt spacing between modeled values can be extrapolated.
- 3D Thermal modeling conducted by Morrison Hershfield using steel building components manufactured by Steelway Building Systems. Software validated as part of ASHRAE Research Project 1365-RP.

Energy Code Requirements: Canada

Thermal Wall System: Cavity Filled - Narrow Rib Out Girts at 2'-0"

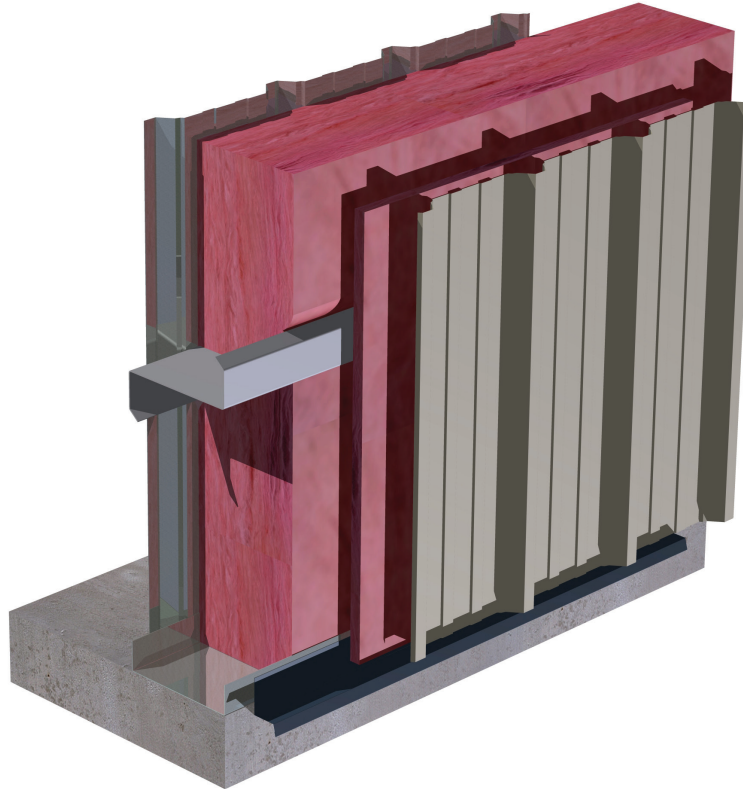

Girts at 2'-0" (minimum spacing), StormSeal exterior panels with interior liner

Rated Value of Insulation (nominal)		Overall Insulation Thickness mm (in)	Girt Depth mm (in)	Effective Assembly U-Value W/(m²K) (BTU/(hr•FT²•°F))	Effective Assembly R-Value m²K/W (hr•FT²•°F/BTU)	Highest Zone Meet with NECB 2017 / OBC SB-10-2016	Highest Zone Meet with ASHRAE 90.1-2013
RSI	R						
6.34 (4.40+1.94)	36 (25 + 11)	279 (11)	203 (8)	0.529 (0.093)	1.89 (R-10.7)	–	–
7.74 (5.80+1.94)	44 (33 + 11)	330 (13)	254 (10)	0.474 (0.083)	2.11 (R-12.0)	–	–
8.63 (6.69+1.94)	49 (38 + 11)	381 (15)	305 (12)	0.440 (0.077)	2.27 (R-12.9)	–	–

Notes:

- Standard Batt insulation with a maximum Thermal Conductivity of 0.042 W/(m•K) [0.29 BTU/(hr•FT²•°F)] per inch. Insulation not provided by Steelway Building Systems.
- Standard 3" Batt insulation R11 (RSI 1.94) over the top of girt sections.
- Steel liner on girt inside flange.
- Effective U values for girt spacing between modeled values can be extrapolated.
- 3D Thermal modeling conducted by Morrison Hershfield using steel building components manufactured by Steelway Building Systems. Software validated as part of ASHRAE Research Project 1365-RP.

Thermal Wall System: Cavity Filled - Wide Rib Out

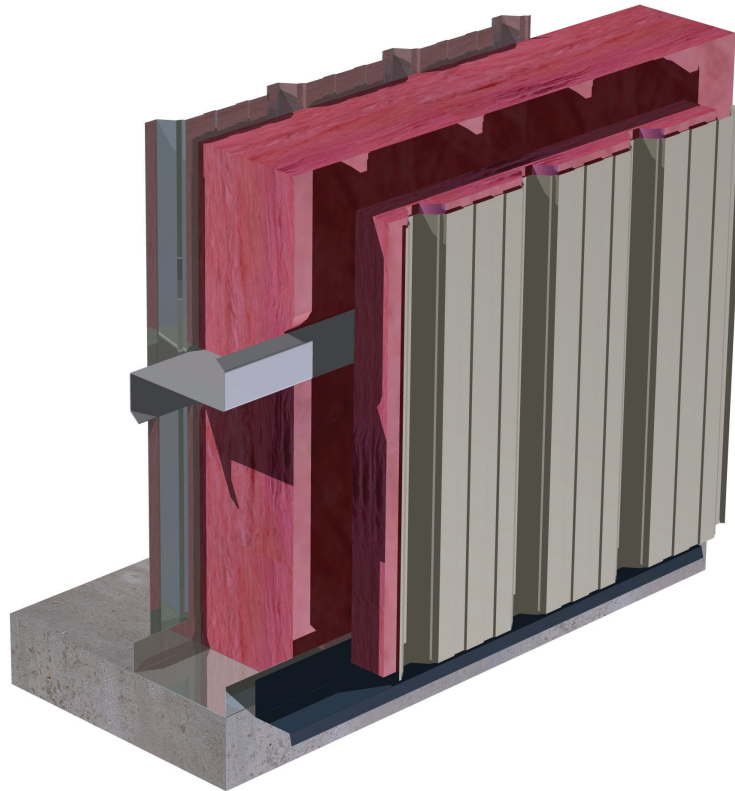

StormSeal exterior panels (wide rib out) with interior liner, girt spacing as listed below

Girt Spacing mm (ft)	Rated Value of Insulation (nominal)		Overall Insulation Thickness mm (in)	Girt Depth mm (in)	Effective Assembly U-Value W/(m ² K) (BTU/(hr•FT ² •°F))	Effective Assembly R-Value m ² K/W (hr•FT ² •°F/BTU)	Highest Zone Meet with NECB 2017 / OBC SB-10- 2016	Highest Zone Meet with ASHRAE 90.1-2013
	RSI	R						
1524 (5'-0")	6.34 (4.40+1.94)	36 (25 + 11)	279 (11)	203 (8)	0.261 (0.046)	3.83 (R-21.8)	5	4A,4B, 4C
610 (2'-0")	6.34 (4.40+1.94)	36 (25 + 11)	279 (11)	203 (8)	0.400 (0.071)	2.50 (R-14.2)	–	–

Notes:

- Standard Batt insulation with a maximum Thermal Conductivity of 0.042 W/(m•K) [0.29 BTU/(hr•FT²•°F)] per inch. Insulation not provided by Steelway Building Systems.
- Standard 3" Batt insulation R11 (RSI 1.94) over the top of girt sections.
- Steel liner on girt inside flange.
- Effective U values for girt spacing between modeled values can be extrapolated.
- 3D Thermal modeling conducted by Morrison Hershfield using steel building components manufactured by Steelway Building Systems. Software validated as part of ASHRAE Research Project 1365-RP.

Energy Code Requirements: Canada

Thermal Wall System: Cavity Filled - 1" Thermal Blocks Girts at 5'-0"

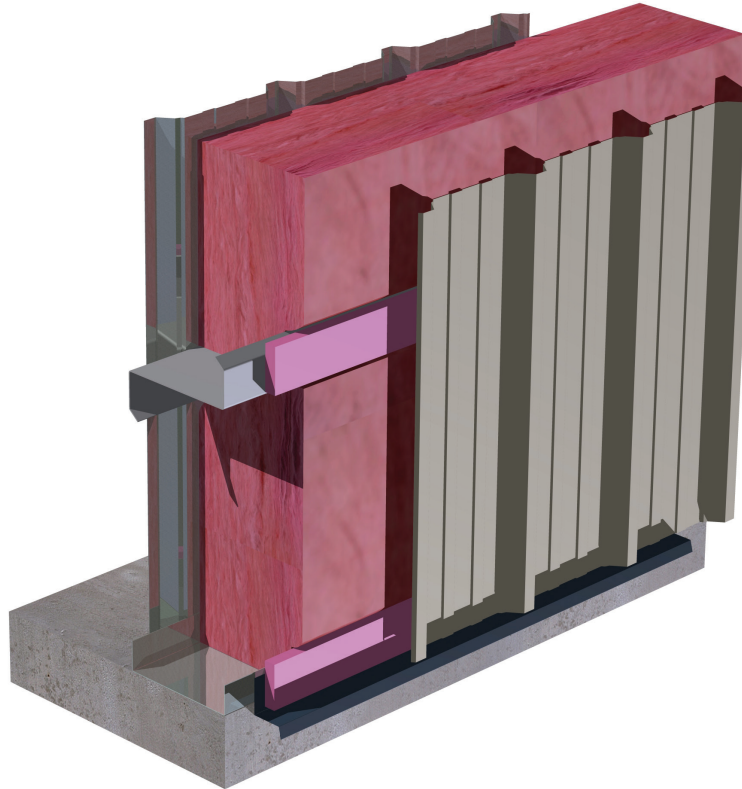

Girts at 5'-0" (minimum spacing), StormSeal exterior panels with interior liner

Rated Value of Insulation (nominal)		Overall Insulation Thickness mm (in)	Girt Depth mm (in)	Effective Assembly U-Value W/(m ² K) (BTU/(hr•FT ² •°F))	Effective Assembly R-Value m ² K/W (hr•FT ² •°F/BTU)	Highest Zone Meet with NECB 2017 / OBC SB-10- 2016	Highest Zone Meet with ASHRAE 90.1-2013
RSI	R						
5.28	30	229 (9)	203 (8)	0.249 (0.044)	3.98 (R-22.6)	5	6A, 6B
6.25	35.5	279 (11)	254 (10)	0.232 (0.041)	4.31 (R-24.5)	6	6A,6B
6.69	38	330 (13)	305 (12)	0.220 (0.039)	4.54 (R-25.8)	6	8

Notes:

- Standard Batt insulation with a maximum Thermal Conductivity of 0.042 W/(m•K) [0.29 BTU/(hr•FT²•°F)] per inch. Insulation not provided by Steelway Building Systems.
- Thermal block's to have a maximum Thermal Conductivity of 0.029 W/(m•K) [0.20 BTU/(hr•FT²•°F)] per inch.
- Minimum 1" (25mm) [R5 (RSI 0.88)] thermal block on top of girts.
- Steel liner on girt inside flange.
- Effective U values for girt spacing between modeled values can be extrapolated.
- 3D Thermal modeling conducted by Morrison Hershfield using steel building components manufactured by Steelway Building Systems. Software validated as part of ASHRAE Research Project 1365-RP.

Energy Code Requirements: Canada

Thermal Wall System: Cavity Filled - 1" Thermal Blocks Girts at 2'-0"

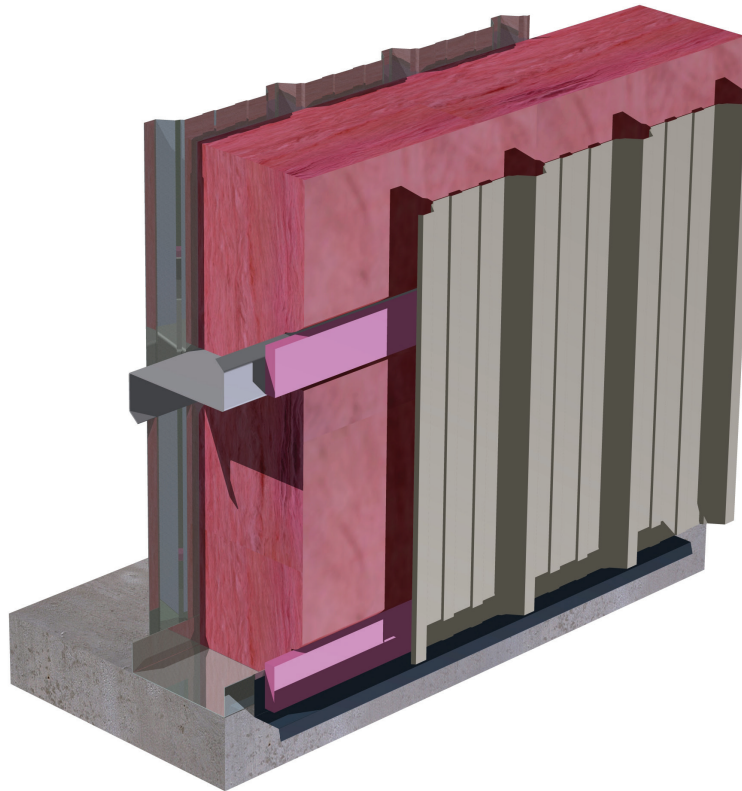

Girts at 2'-0" (minimum spacing), StormSeal exterior panels with interior liner

Rated Value of Insulation (nominal)		Overall Insulation Thickness mm (in)	Girt Depth mm (in)	Effective Assembly U-Value W/(m ² K) (BTU/(hr•FT ² •°F))	Effective Assembly R-Value m ² K/W (hr•FT ² •°F/BTU)	Highest Zone Meet with NECB 2017 / OBC SB-10- 2016	Highest Zone Meet with ASHRAE 90.1-2013
RSI	R						
5.28	30	229 (9)	203 (8)	0.361 (0.063)	2.77 (R-15.7)	–	–
6.25	35.5	279 (11)	254 (10)	0.338 (0.059)	2.96 (R-16.8)	–	–
6.69	38	330 (13)	305 (12)	0.332 (0.058)	3.01 (R-17.1)	–	4A, 4B, 4C

Notes:

- Standard Batt insulation with a maximum Thermal Conductivity of 0.042 W/(m•K) [0.29 BTU/(hr•FT²•°F)] per inch. Insulation not provided by Steelway Building Systems.
- Thermal block's to have a maximum Thermal Conductivity of 0.029 W/(m•K) [0.20 BTU/(hr•FT²•°F)] per inch.
- Minimum 1" (25mm) [R5 (RSI 0.88)] thermal block on top of girts.
- Steel liner on girt inside flange.
- Effective U values for girt spacing between modeled values can be extrapolated.
- 3D Thermal modeling conducted by Morrison Hershfield using steel building components manufactured by Steelway Building Systems. Software validated as part of ASHRAE Research Project 1365-RP.

Thermal Wall System: Cavity Filled - 1" Rigid Board

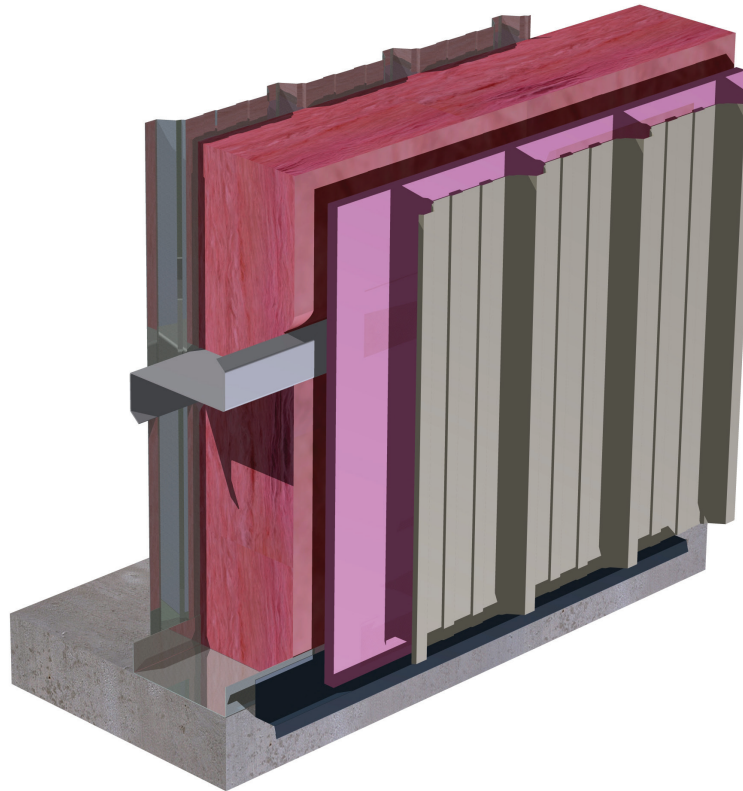

StormSeal exterior panels with interior liner, girt spacing as listed below

Girt Spacing mm (ft)	Rated Value of Insulation (nominal)		Overall Insulation Thickness mm (in)	Girt Depth mm (in)	Effective Assembly U-Value W/(m ² K) (BTU/(hr•FT ² •°F))	Effective Assembly R-Value m ² K/W (hr•FT ² •°F/BTU)	Highest Zone Meet with NECB 2017 / OBC SB-10- 2016	Highest Zone Meet with ASHRAE 90.1-2013
	RSI	R						
1524 (5'-0")	5.28 (4.40 + 0.88)	30 (5 + 25)	203 (8)	203 (8)	0.237 (0.042)	4.23 (R-24.0)	6	6A, 6B
610 (2'-0")	5.28 (4.40 + 0.88)	30 (5 + 25)	203 (8)	203 (8)	0.348 (0.061)	2.87 (R-16.3)	–	–

Notes:

- Standard Batt insulation with a maximum Thermal Conductivity of 0.042 W/(m•K) [0.29 BTU/(hr•FT²•°F)] per inch. Insulation not provided by Steelway Building Systems.
- Rigid board to have a maximum Thermal Conductivity of 0.029 W/(m•K) [0.20 BTU/(hr•FT²•°F)] per inch.
- Minimum 1" (25mm) [R5 (RSI 0.88)] rigid board on top of girts.
- Steel liner on girt inside flange.
- Effective U values for girt spacing between modeled values can be extrapolated.
- 3D Thermal modeling conducted by Morrison Hershfield using steel building components manufactured by Steelway Building Systems. Software validated as part of ASHRAE Research Project 1365-RP.

Thermal Wall System: Thermal Notched Zee Stand-off
Girts at 5'-0"

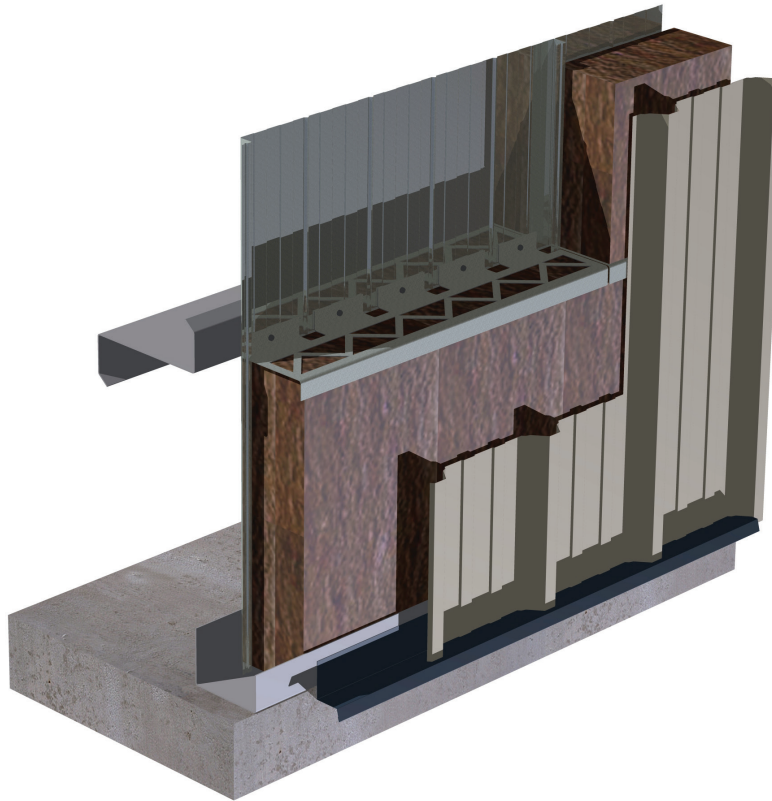

Girts at 5'-0", StormSeal exterior panels with LinerSeal

Rated Value of Insulation (nominal)		Notched Thermal Zee Depth mm (in)	Effective Assembly U-Value W/(m ² K) (BTU/(hr•FT ² •°F))	Effective Assembly R-Value m ² K/W (hr•FT ² •°F/BTU)	Highest Zone Meet with NECB 2017 / OBC SB-10-2016	Highest Zone Meet with ASHRAE 90.1-2013
RSI	R					
4.44	25	152 (6.0)	0.272 (0.048)	3.67 (R-20.8)	5	4A, 4B, 4C
5.64	32	191 (7.5)	0.230 (0.040)	4.35 (R-24.7)	6	6A, 6B
6.34	36	216 (8.5)	0.209 (0.037)	4.77 (R-27.1)	7A,7B	8

Notes:

- Standard Mineral Wool insulation with a maximum Thermal Conductivity of 0.034 W/(m•K) [0.238 BTU/(hr•FT²•°F)] per inch. Insulation not provided by Steelway Building Systems.
- Thermal tape to have a maximum Thermal Conductivity of 0.031 W/(m•K) [0.22 BTU/(hr•FT²•°F)] per inch.
- Minimum 1/4" (6mm) [R1.15 (RSI 0.203)] thermal tape between girts and liner.
- Steel liner on girt inside flange.
- Effective U values for girt spacing between modeled values can be extrapolated.
- 3D Thermal modeling conducted by Morrison Hershfield using steel building components manufactured by Steelway Building Systems. Software validated as part of ASHRAE Research Project 1365-RP.

Thermal Wall System: Thermal Notched Zee Stand-off Girts at 2'-0"

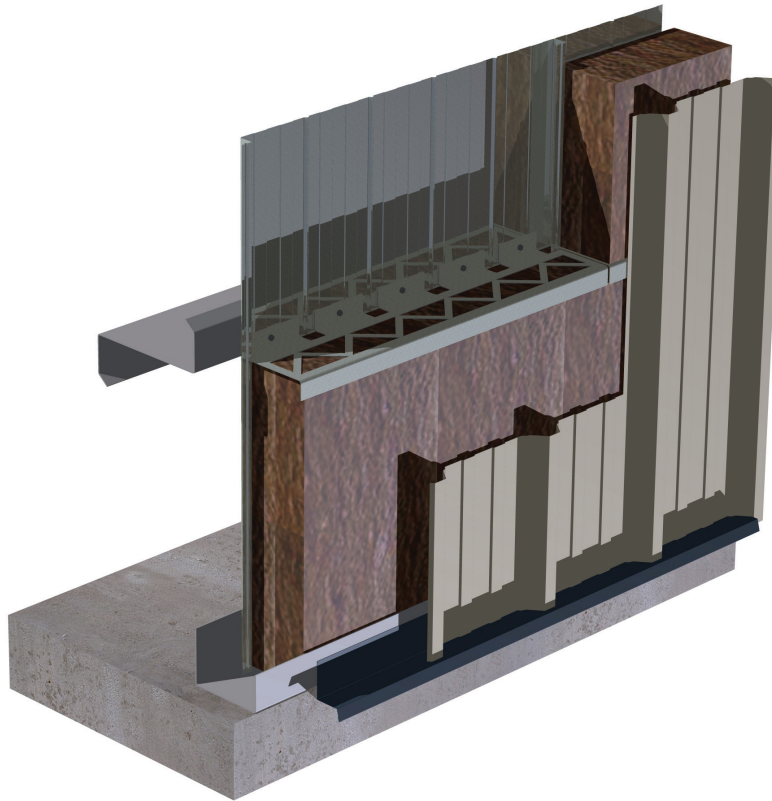

Girts at 2'-0", StormSeal exterior panels with LinerSeal

Rated Value of Insulation (nominal)		Notched Thermal Zee Depth mm (in)	Effective Assembly U-Value W/(m ² K) (BTU/(hr•FT ² •°F))	Effective Assembly R-Value m ² K/W (hr•FT ² •°F/BTU)	Highest Zone Meet with NECB 2017 / OBC SB-10-2016	Highest Zone Meet with ASHRAE 90.1-2013
RSI	R					
4.44	25	152 (6.0)	0.342 (0.060)	2.92 (R-16.6)	–	–
5.64	32	191 (7.5)	0.299 (0.053)	3.34 (R-19.0)	4	4A, 4B, 4C
6.34	36	216 (8.5)	0.276 (0.049)	3.62 (R-20.5)	5	4A, 4B, 4C

Notes:

- Standard Mineral Wool insulation with a maximum Thermal Conductivity of 0.034 W/(m•K) [0.238 BTU/(hr•FT²•°F)] per inch. Insulation not provided by Steelway Building Systems.
- Thermal tape to have a maximum Thermal Conductivity of 0.031 W/(m•K) [0.22 BTU/(hr•FT²•°F)] per inch.
- Minimum 1/4" (6mm) [R1.15 (RSI 0.203)] thermal tape between girts and liner.
- Steel liner on girt inside flange.
- Effective U values for girt spacing between modeled values can be extrapolated.
- 3D Thermal modeling conducted by Morrison Hershfield using steel building components manufactured by Steelway Building Systems. Software validated as part of ASHRAE Research Project 1365-RP.