

## Cladding Details

- Optional colours and gauges available. Minimum order quantities may apply.
- SRI = Solar Reflectance Index, calculated at medium wind condition per ASTM E1980
- Liner White is Galvanized substrate and is for Interior Use Only.
- ✓ denotes standard coverage.  
◆ represents 30" wide coverage.
- Standard 20000 series colours use a Silicone Modified Polyester paint system.
- Please visit [steelway.com](http://steelway.com) or [exsteel.com](http://exsteel.com) for updates to this cladding guide.

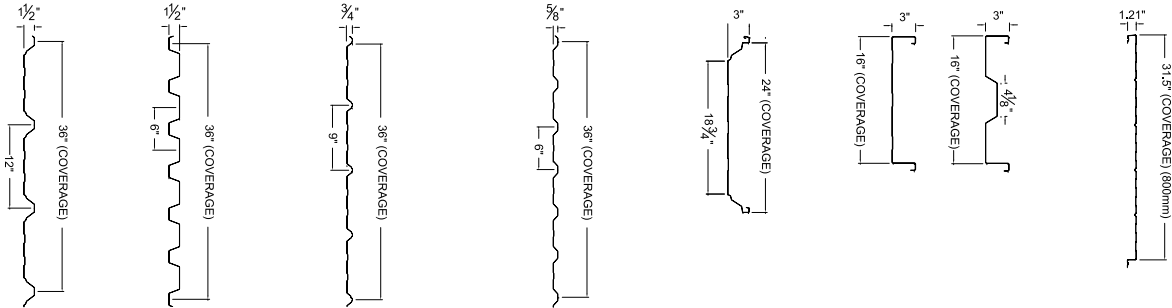

Profile Type	Trims & Flashings			StormSeal		StrucSeal		VersaSeal			DiamondSeal			RTL-24		TechLoc			LinerSeal		
	Gauge of Steel	29	26	24	26	24	26	24	29	26	24	29	26	24	24	22	Flat		Sculptured	26	24

Colour	Code	SRI																						
Dark Brown	QC 28229	10	✓	✓	✓	✓	✓	◆	◆	✓				✓										
Slate Blue	QC 28260	27	✓	✓	✓	✓	✓	✓	✓	✓				✓										
Bone White	QC 28273	56	✓	✓	✓	✓	✓	✓	✓	✓				✓										
Stone Grey	QC 28305	51	✓	✓	✓	✓	✓	✓	✓	✓				✓										
Charcoal	QC 28306	30	✓	✓	✓	✓	✓	◆	◆	✓				✓				✓						
Tan	QC 28315	35	✓	✓	✓	✓	✓	◆	◆	✓				✓										
White White	QC 28317	65	✓	✓	✓	✓	✓	✓	✓	✓	✓	✓	✓	✓										
Coffee	QC 28326	24	✓							✓				✓										
Regent Grey	QC 28730	39	✓	✓	✓	✓	✓	◆	◆	✓				✓										
Bright White	QC 28783	79		✓	✓	✓	✓	◆	◆						✓	✓	✓		✓	✓	✓			
Pebble Khaki	QC 28129	45	✓	✓	✓	✓	✓	◆	◆	✓				✓										
Dark Red	QC 28250	24	✓							✓				✓										
Tile Red	QC 28259	31	✓	✓	✓	✓	✓	◆	◆					✓										
Black	QC 28262	0	✓	✓	✓	✓	✓	◆	◆	✓				✓										
Melchers Green	QC 28307	3	✓	✓	✓	✓	✓	◆	◆	✓				✓										
Green	QC 28329	26		✓	✓	✓	✓	◆	◆															
Heron Blue	QC 28330	6		✓	✓	✓	✓	◆	◆															
Antique Linen	QC 28696	69		✓	✓	✓	✓	◆	◆															
Liner White	QC 5712	N/A		✓						✓				✓										
Chocolate Brown	QC 60034	3.8	✓							✓				✓										
Graphite Grey	QC 60035	6.7	✓							✓				✓										
Jet Black	QC 60039	0	✓							✓				✓										
Sepia Brown	QC 60041	0	✓							✓				✓										
Bright Red	QC 28386	38	✓							✓				✓										
Plain Galvalume Plus	AZ 165	62	✓	✓	✓	✓	✓	◆	◆	✓				✓	✓	✓								
Galvanized	G 90 / Z275	46	✓							✓				✓										
Galvaneal	AZ75 / ZF75	N/A		✓	✓																✓	✓		